







Power Jacks has a proud engineering heritage dating from the earliest years of the 20th Century. A heritage that is about excellence: about visionary design, technical expertise, robust product manufacture and customer care.

Those remain the defining characteristics of Power Jacks today as we design and build screw jacks, bevel gearboxes, linear actuators and roller screws. In fact they're more important than ever as we take our service delivery to you – the customer – to new levels of performance.

There's even more to it than that, however. We harness our engineering knowledge and capabilities not only to create a diverse linear motion product portfolio, but also to engineer individual solutions: to create customised products that help you improve your business.

The best people, proven products, quality performance: a combination that sets us apart.

POWER THAT'S ELECTRIC.

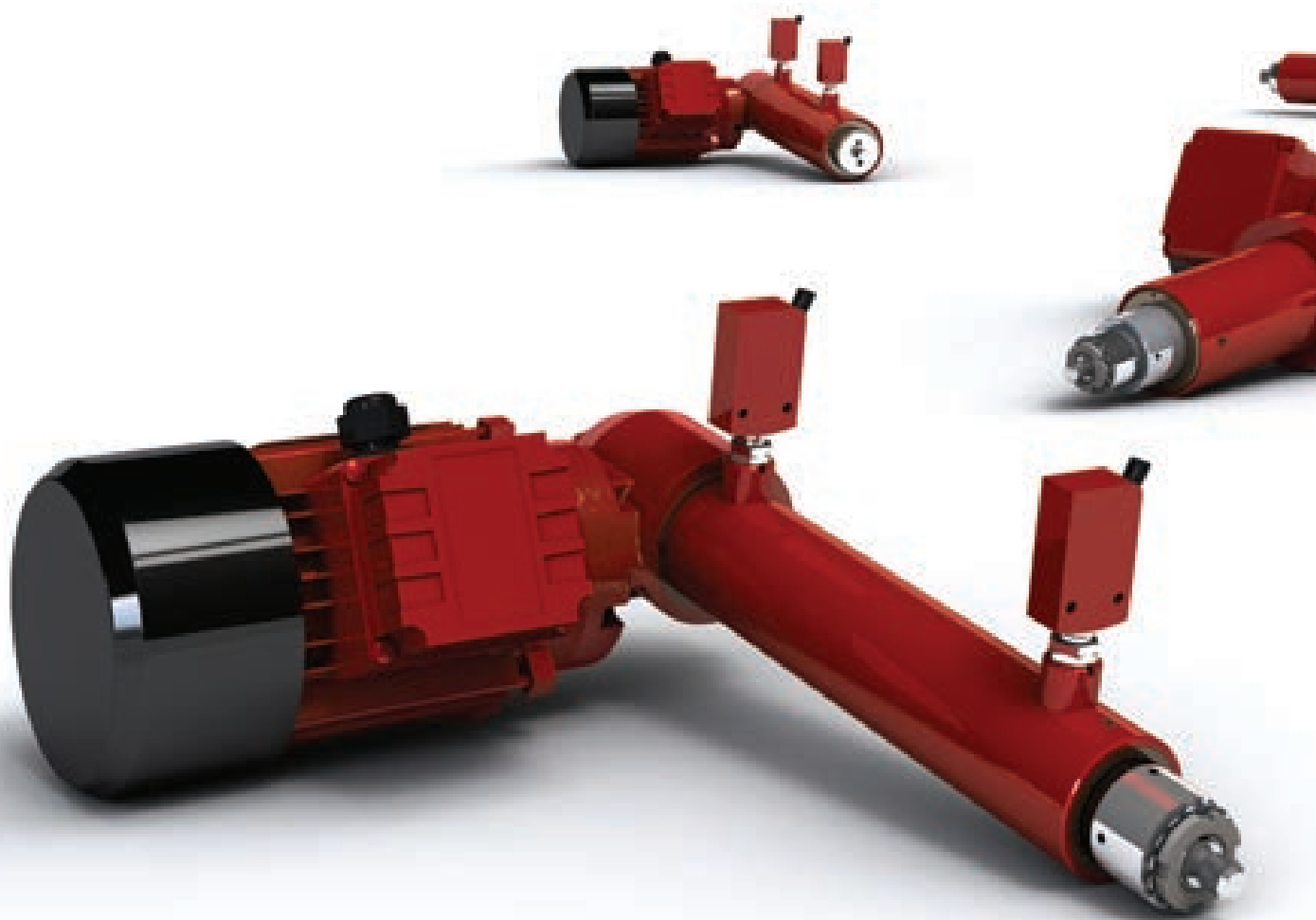

# CONTENTS

EMA Features	6 - 7
EMA Options	8 - 9
Product Code	10-11
Typical Applications	12
General Performance	13
Model-I with Emergency Overload Clutch	14
Model-I with NO Emergency Overload Clutch	15
Model-C with Emergency Overload Clutch	16
Model-C with NO Emergency Overload Clutch	17
Model-H with Emergency Overload Clutch	18
Model-H with NO Emergency Overload Clutch	19
EMA Motor Types	20
EMA Motion Control	21 - 22
End Fittings for Actuator Ram	23
EMA Mountings	24
Other Products	25

## Notes:

- All information in this document is subject to change without notice
- All rights reserved by Power Jacks Limited. May not be copied in whole or in part
- ©Power Jacks Limited 1987, Aberdeenshire, Scotland, United Kingdom

## OUR LINEAR ACTUATORS DELIVER POWERFUL, SMOOTH AND PRECISE LINEAR MOTION

Our EMA industrial linear actuator is designed for low to medium duty applications, with loads up to 10kN. It uses a precision spiroid gear set that delivers superior performance when compared to a similar size worm gear set.

Depending on the performance required, the gear set drives either a machine screw or ball screw to move the ram. And a wide range of options, including clutches and limit switches, are available to suit most applications.

### Overview of EMA Linear Actuator Range

#### What is EMA Linear Actuator?

EMA is an abbreviation for Electro Mechanical Actuator, which consists of either a trapezoidal or ball lead screw, driven by an electric motor through spiroid gearing. The screw converts the rotary motion into linear movement. As the screw rotates, the nut extends and retracts the ram, which is attached to the load.

#### The EMA Linear Actuator Range

There are 3 standard EMA models, all available in a right-angle drive configuration.

- Intermittent duty model (I), incorporating a trapezoidal screw
- Medium duty model (C), incorporating a ball screw
- High speed & medium duty model (H), incorporating a ball screw

Where the standard range does not meet the application specification, special actuators can be designed to meet customers' specific requirements.

#### Dynamic Load Capacity and Speed

The dynamic load capacity range is up to 10 kN. A defined range of linear speeds from 135 mm/minute to 5510 mm/minute is available. The speed range is achieved by using a combination of gearbox ratios, screw leads and standard motor speeds.

#### Drives

As standard, the units are available with 240V/415V AC or 24V DC motors, with or without a brake. The type of motors required is dependent on the customer's application. The motors are mounted to the actuator on a 63C Face Flange Mounting.

#### Stroke

Each model can be provided with a stroke length up to the maximum shown in the Technical Charts. The stroke is defined by the customer. For a tensile load, greater maximum strokes can be accommodated, depending on the linear speed. Where the stroke required exceeds the maximum shown, or there is a high static load, please contact our Technical Sales Department.

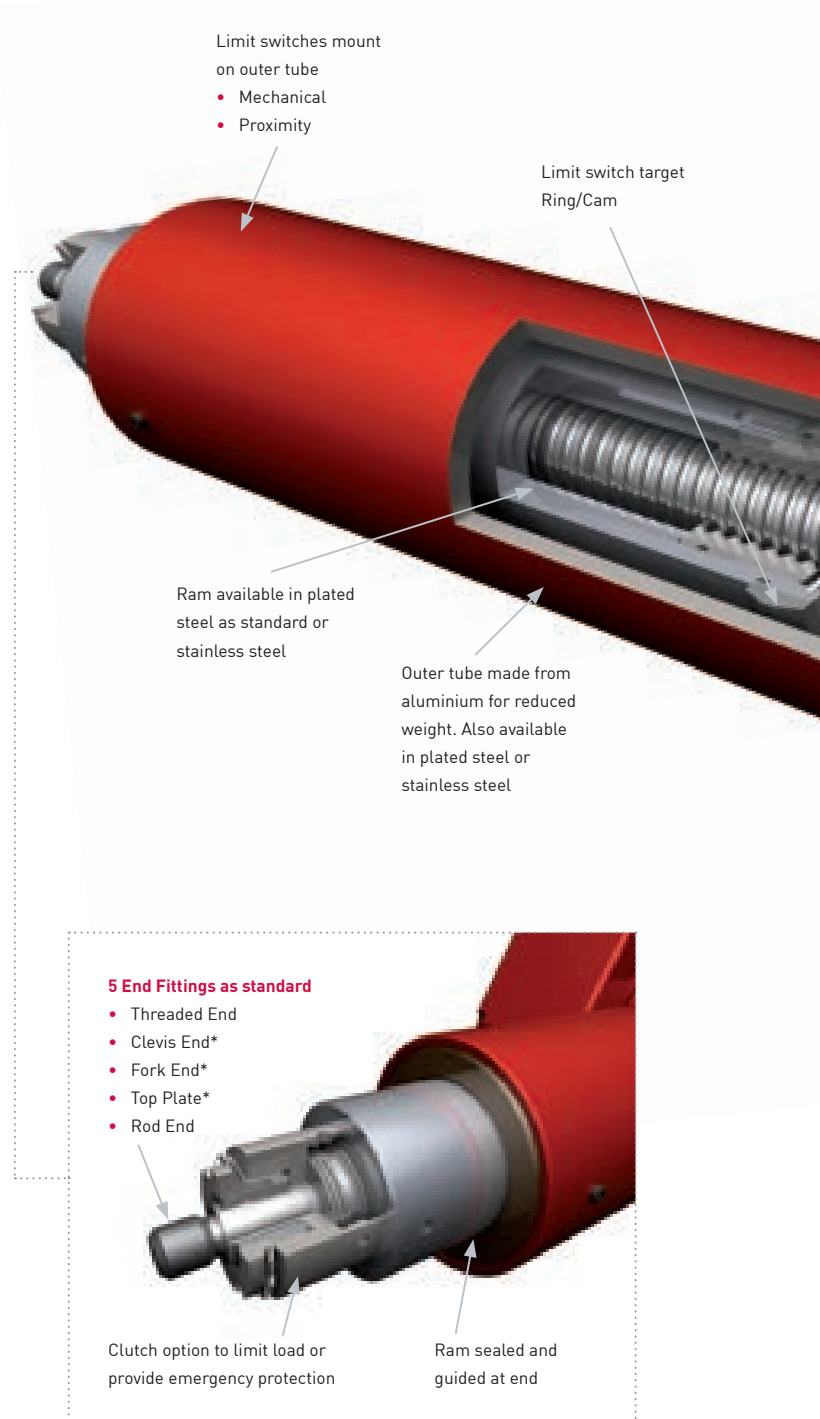

\* Zinc plated as standard stainless steel options available

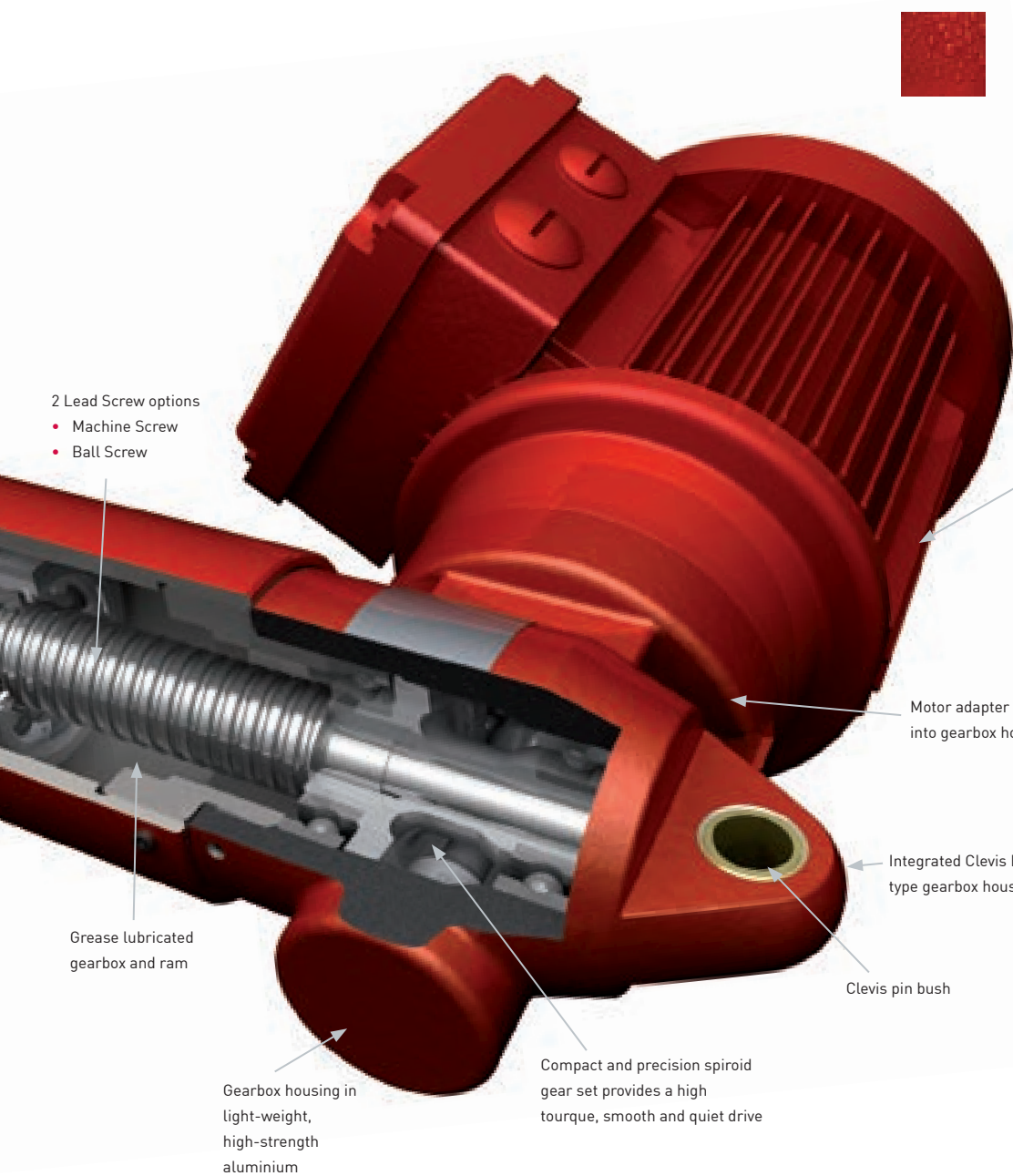

#### Corrosion Protection

To suit all economic needs

- Standard industrial paint finish
- Arduous environment paint finish
- Customer specified paint
- Plated finish (not including motor)
- Bellows boot for ram
- Stainless steel options available

#### Electric Motor

- 3 - Phase AC
- 1 - Phase AC
- DC
- Servo
- All available with or without a brake

- 2 Lead Screw options
- Machine Screw
  - Ball Screw

Grease lubricated gearbox and ram

Gearbox housing in light-weight, high-strength aluminium

Compact and precision spiroid gear set provides a high torque, smooth and quiet drive

Motor adapter integrated into gearbox housing

Integrated Clevis End for I&C type gearbox housings

Clevis pin bush

#### Standard Features

- Choice of AC or DC motor drives
- Choice of end fittings: clevis, fork top plate, rod or threaded end
- Trunnion Mounting
- Limit Switches

#### Emergency Overload Clutch

The emergency overload clutch is a device, which is mounted on the actuator ram, which will slip when the torque to drive the load exceeds the limit set. If the load is axially locked, or if a torque greater than the clutch setting is required to move the load, the clutch will disengage the load from the ram and prevent the motor from overloading the actuator components. Please note that the clutch is an emergency device and should not be used for reversing the actuator direction.

#### Limit Switches

Limit switches are fitted to provide end of stroke or ultimate over travel safety. They are mounted on the outer tube of the actuator

and are tripped by a collar on the ram. They are set at a fixed length defined by the customer (see dimensional page for details). Adjustable Limit Switches can be provided on request, consult Power Jacks.

#### Guiding the Load

Side loads on the actuator ram should be avoided by ensuring that the load is guided. The load guide mechanism should resist the torque developed at the ram by the screw mechanism. A guided ram can be supplied on request, which utilises a keyway in the inner ram, eliminates the need for torsional restraint and therefore allows flexibility in the choice of end fitting.

#### Construction

All units are constructed and finished to suit industrial operating conditions. The actuator gearbox and outer tube are painted aluminium or plated for protection and the ram is zinc plated steel. The actuator is sealed at the ram. Stainless steel options available on request.

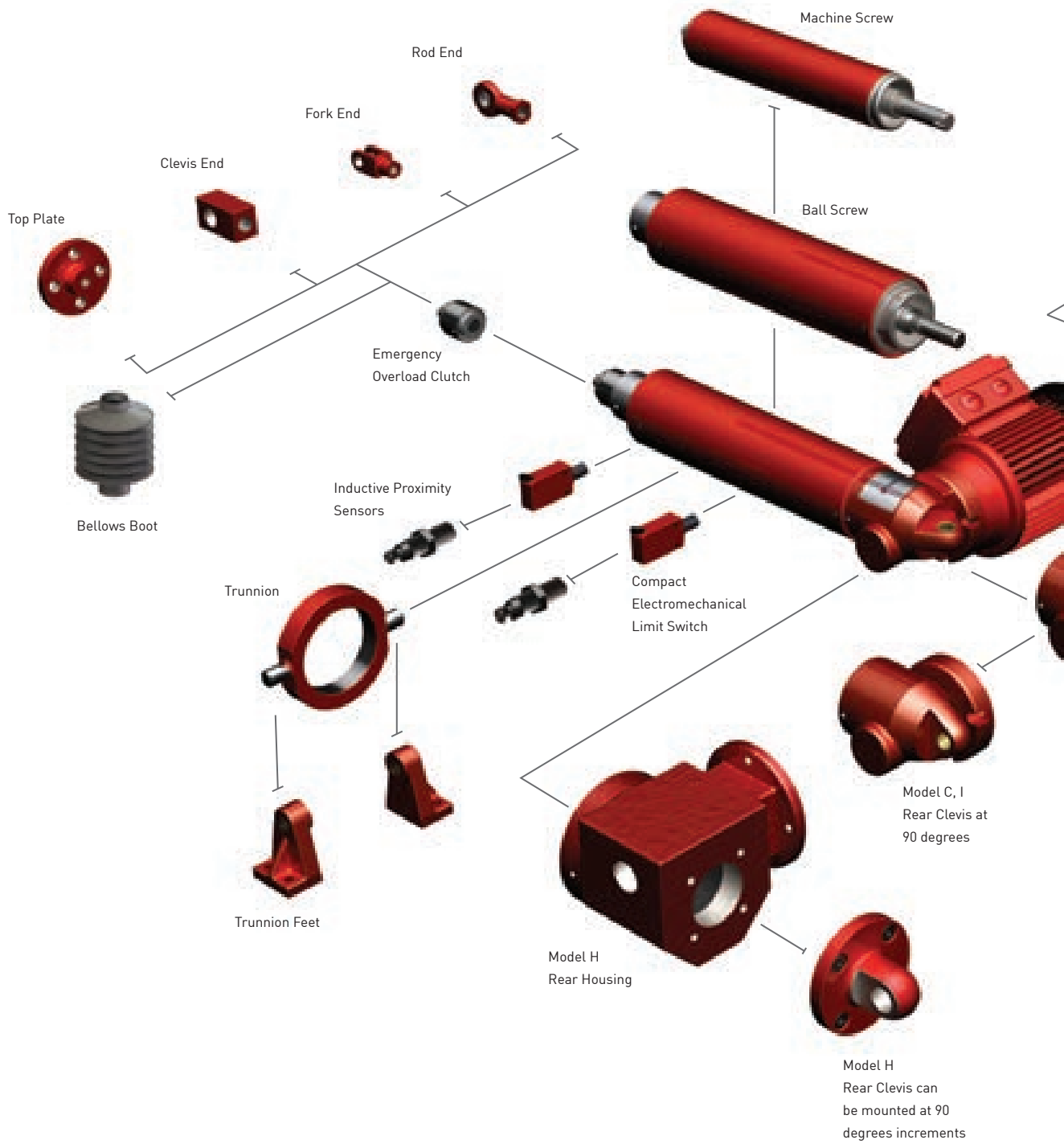



Electric Motor 3 Phase  
AC with Brake

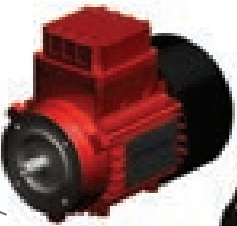

Electric Motor  
3 Phase AC



Electric Motor  
1 Phase AC



Electric Motor 1  
Phase AC with Brake



Electric Motor  
24V DC



Model C, I  
Standard Rear  
Clevis



Incremental / absolute encoders  
(fitted to motor or actuator gearbox)

Stainless steel options available on request.

### EA000AR-0135-0300-FD00-E100L10

EMA Linear Actuator, Model-I, Standard Design, Right angled motor drive, 135mm/min linear speed, 300mm stroke, fork end on ram, clevis at 90 degrees on gearbox, electric motor 415VAC 3-Phase 50Hz, No Brake, No Clutch, 2 end of stroke fixed mechanical limit switches, limit switch position-1 (standard), Standard paint lubrication & seals.

1	2	3	4	5	6	7	8	9	10	11	12	13	14	15	16	17	18	19	20	21	22	23	24	25	26	27	28	29	30
E	A	0	0	0	A	R	-	0	1	3	5	-	0	3	0	0	-	F	D	0	0	-	E	1	0	0	L	1	0

GROUP-1 - Linear Actuator Definition

GROUP-2 - Linear Actuator Features

GROUP-3 - Accessories

GROUP-1 - Linear Actuator Definition

<b>1 - Linear Actuator Series</b>	
E	EMA Series

<b>2-5 - Model / Size</b>	
A000	Model-I
A001	Model-C
A002	Model-H

<b>6 - Actuator Design Type</b>	
A	Standard Design

<b>7 - Drive / Motor Orientation (Relative to Ram)</b>	
R	Right Angled

<b>8 - Character Space</b>	
----------------------------	--

<b>9-12 - Linear Speed (mm/min)</b>	
XXXX	0 - 9,999 mm/min

<b>13 - Character Space</b>	
-----------------------------	--

GROUP-2 - Linear Actuator Features

<b>14-17 - Stroke (mm) #1</b>	
0000	0-9999

<b>18 - Character Space</b>	
-----------------------------	--

<b>19 - Ram End Type</b>	
E	Threaded End
C	Clevis End
T	Top Plate
F	Fork End
R	Rod End

<b>20 - Gearbox Mounting</b>	
C	Rear Clevis
D	Rear Clevis 90deg
T	Trunnion Mount Standard #2
U	T + Trunnion Feet #2
X	Trunnion Mount 90deg #2
Y	X + Trunnion Feet #2

<b>21 - Ram Feature - 1</b>	
0	None
A	Zero-Backlash (Anti-Backlash for Machine Screws)
K	Anti-Rotation (Keyed) Ram - Low Duty #3
R	Anti-Rotation (Low Duty) & Zero-Backlash Ram

<b>22 - Ram Feature - 2</b>	
0	None
1	Bellows Boot - Fabric
2	Bellows Boot - Rubber
A	Stainless Steel Ram #4
B	Stainless Steel Ram & Bellows Boot - Fabric #4
C	Stainless Steel Ram & Bellows Boot - Rubber #4

<b>23 - Character Space</b>	
-----------------------------	--

**GROUP-3 - Accessories**

<b>24 - Drive Type</b>	
E	Electric Motor (Standard)
F	Electric Motor and auxiliary shaft on gearbox
G	Electric Motor with auxiliary shaft
H	Hand Wheel
J	Electric Motor & Hand Wheel
M	No Motor - Just Motor Mount, B14
N	No Motor - Just Motor Mount, B5
S	No Motor Fittings - solid shaft input - single ended
T	No Motor Fittings - solid shaft input - double ended

<b>25 - Motor Power Supply</b>	
0	None - No Motor
1	415VAC 3-Phase, 50/60Hz Induction Motor (Standard)
2	220VAC 1-Phase, 50/60Hz Induction Motor
3	24VDC Permanent Magnet
4	AC Servo Motor - 3-Phase, AC
5	AC Servo Motor - 1-Phase, AC
6	DC Servo Motor

<b>26 - Brake &amp; Clutch</b>	
0	No Brake, No Clutch
B	Brake
C	Clutch
D	Brake & Clutch

<b>27 - Motion Feedback</b>	
0	None
A	Encoder - Absolute - Motor Mounted
B	Encoder - Absolute - Gearbox Mounted
C	Encoder - Incremental - Motor Mounted
D	Encoder - Incremental - Gearbox Mounted
E	Resolver - Motor Mounted #5

<b>28 - Limit Switches</b>	
0	No Limit Switches
L	Mechanical Limit switches - Fixed (2 EOS) #6
M	Mechanical Limit switches - Adjustable (2 EOS) #6 #7
P	Proximity Sensors - Fixed (2 EOS) #6
Q	Proximity Sensors - Adjustable (2 EOS) #6 #7

<b>29 - Limit Switch Position #8</b>	
0	No Limit Switches
1	Limit Switch Position 1 (Standard)
2	Limit Switch Position 2
3	Limit Switch Position 3
4	Limit Switch Position 4

<b>30 - Paint, Lubricant, Seals #9 #10</b>			
0	Standard Paint, Lubricant & Seals	G	Standard Primer, Lubricant & Seals
1	Standard Paint & Food Grade Lubricant & Standard Seals	H	Standard Primer & Food Grade Lubricant & Standard Seals
2	Standard Paint, Nuclear Grade Lubricant & Seals	I	Standard Primer, Nuclear Grade Lubricant & Seals
3	Standard Paint, High Temperature Lubricant & Seals	J	Standard Primer, High Temperature Lubricant & Seals
4	Standard Paint, Low Temperature Lubricant & Seals	K	Standard Primer, Low Temperature Lubricant & Seals
5	Standard Paint, Biodegradeable Lubricant & Standard Seals	L	Standard Primer, Biodegradeable Lubricant & Standard Seals
A	No Paint, Standard Lubricant & Seals	M	Epoxy Paint, Standard Lubricant & Seals
B	No Paint & Food Grade Lubricant & Standard Seals	N	Epoxy Paint & Food Grade Lubricant & Standard Seals
C	No Paint, Nuclear Grade Lubricant & Seals	P	Epoxy Paint, Nuclear Grade Lubricant & Seals
D	No Paint, High Temperature Lubricant & Seals	R	Epoxy Paint, High Temperature Lubricant & Seals
E	No Paint, Low Temperature Lubricant & Seals	S	Epoxy Paint, Low Temperature Lubricant & Seals
F	No Paint, Biodegradeable Lubricant & Standard Seals	T	Epoxy Paint, Biodegradeable Lubricant & Standard Seals

**Notes:**

- #1 Limited to 2000mm for EMA Actuators.
- #2 Trunnion mount distance / location on ram available as set position as standard for type of actuator, otherwise special design.
- #3 Low Duty Anti-Rotation - Keyed Ram (sliding guide)
- #4 Stainless Steel Ram - inner tube and end fitting all stainless steel.
- #5 Servo motor only
- #6 EOS = End Of Stroke
- #7 Adjustable to set end of stroke limits at each end by +/- 5mm.
- #8 Limit Switch radial position around circumference of actuator ram. 4 standard positions at 90 degree intervals (approx).
- #9 Power Jacks defined paint.
- #10 Power Jacks defined lubricant.

### Tilt/Pivot

EMA Linear Actuators can be used to tilt objects, fixed at one end, up to 180° from their starting positions. The extension and retraction of the actuator causes the object to pivot about its stationary end.

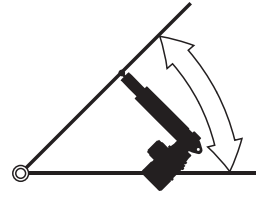

### Lift/Lower

EMA Linear actuators can handle any lifting and lowering application up to 10kN. As the translating tube of the actuator extends and retracts, the object that the actuator is attached to is raised and lowered at a constant speed.

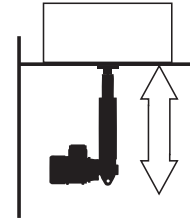

### Position

When an application requires periodic adjustment to the position of an object or objects, EMA linear actuators provide the solution. The motion of the actuator allows the operator to position an object by simply pushing a button.

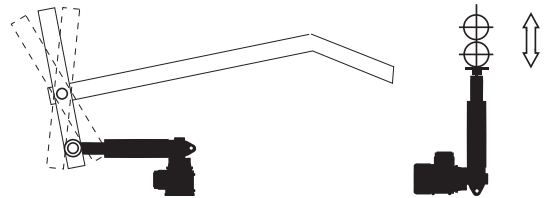

### Roll/Slide

When it is necessary to roll or slide an object or a mechanical assembly into position, an EMA linear actuator is the answer. The movement of the actuator causes the clamping, rolling or sliding of the desired object.

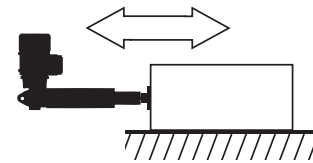

### Open/Close

An EMA linear actuator mounted on a door, gate or valve allows opening and closing operations on either a timed, or on-demand basis. As the actuator retracts the gate is opened at a steady rate; the extension of the actuator returns the gate to a closed position.

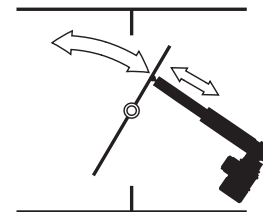

### Tension

EMA linear actuators offer a perfect solution for applications in which tension on a conveyor or webb must be maintained and adjusted. An actuator mounted on a frame or roller extends and retracts to control the tension in the system.

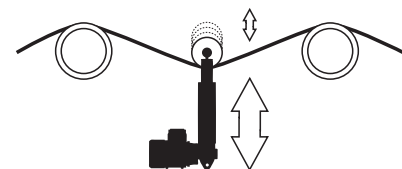

### Lock/Unlock

For moving a locking device such as a pin in and out of retaining slot, EMA linear actuators provides the perfect solution. The motion of the actuator allows the operator to lock and unlock the device smoothly and safely by the touch of a button. Extend and retract limit switches on the actuator can be used as lock/unlock signals for a machines control system.

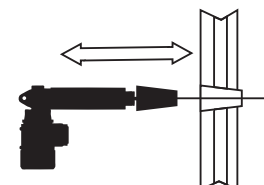

### General Performance

MODEL I (INTERMITTENT DUTY)					
Dynamic Capacity (kN)	10	5	5	5	2.5
Linear Speed (mm/min)	135	200	270	410	820
Motor Power (kW)	0.18	0.18	0.18	0.18	0.18
Motor Frame Size (IEC)	71	63	71	63	63
Motor Poles	6	4	6	2	2
Max Stroke - Compression (mm)	750	750	750	750	750
Max Stroke - Tension (mm)*	2000	2000	2000	2000	2000
Weight - no stroke (kg)	9				
Weight - per 100mm stroke (kg)	0.69				
Ambient Operating Temperature (°C)**	-10°C to +50°C				
Duty Cycle Rating***	Up to 5 cycles per hour, 50 cycles per day. Up to 25% operating time per hour.				

MODEL C (MEDIUM DUTY)					
Dynamic Capacity (kN)	10	10	10	5	2.5
Linear Speed (mm/min)	225	335	685	1370	2740
Motor Power (kW)	0.18	0.18	0.18	0.18	0.18
Motor Frame Size (IEC)	71	63	71	63	63
Motor Poles	6	4	2	2	2
Max Stroke - Compression (mm)	900	900	900	1250	1500
Max Stroke - Tension (mm)*	2000	2000	2000	2000	2000
Weight - no stroke (kg)	10				
Weight - per 100mm stroke (kg)	1.3				
Ambient Operating Temperature (°C)**	-10°C to +50°C				
Duty Cycle Rating***	Up to 20 cycles per hour, 1000 cycles per day. Up to 50% operating time per hour.				

MODEL H (HIGH SPEED & MEDIUM DUTY)					
Dynamic Capacity (kN)	10	10	10	5	5
Linear Speed (mm/min)	900	1375	2755	1805	5510
Motor Power (kW)	0.25	0.37	0.55	0.25	0.55
Motor Frame Size (IEC)	71	71	71	71	71
Motor Poles	6	2	2	6	2
Max Stroke - Compression (mm)	900	900	900	1250	1250
Max Stroke - Tension (mm)*	2000	2000	2000	2000	2000
Weight - no stroke (kg)	12				
Weight - per 100mm stroke (kg)	1.3				
Ambient Operating Temperature (°C)**	-10°C to +50°C				
Duty Cycle Rating***	Up to 20 cycles per hour, 1000 cycles per day. Up to 50% operating time per hour.				

#### Notes:

- \* Longer strokes available on request.
- \*\* Please consult Power Jacks to discuss hostile or hazardous operating environments.
- \*\*\* 1 Cycle = actuator moved to fully extended position then fully retracted position.

Actuator shown with IEC 63, 3-Phase AC Motor.  
For 71 frame size motor refer to Model-H.

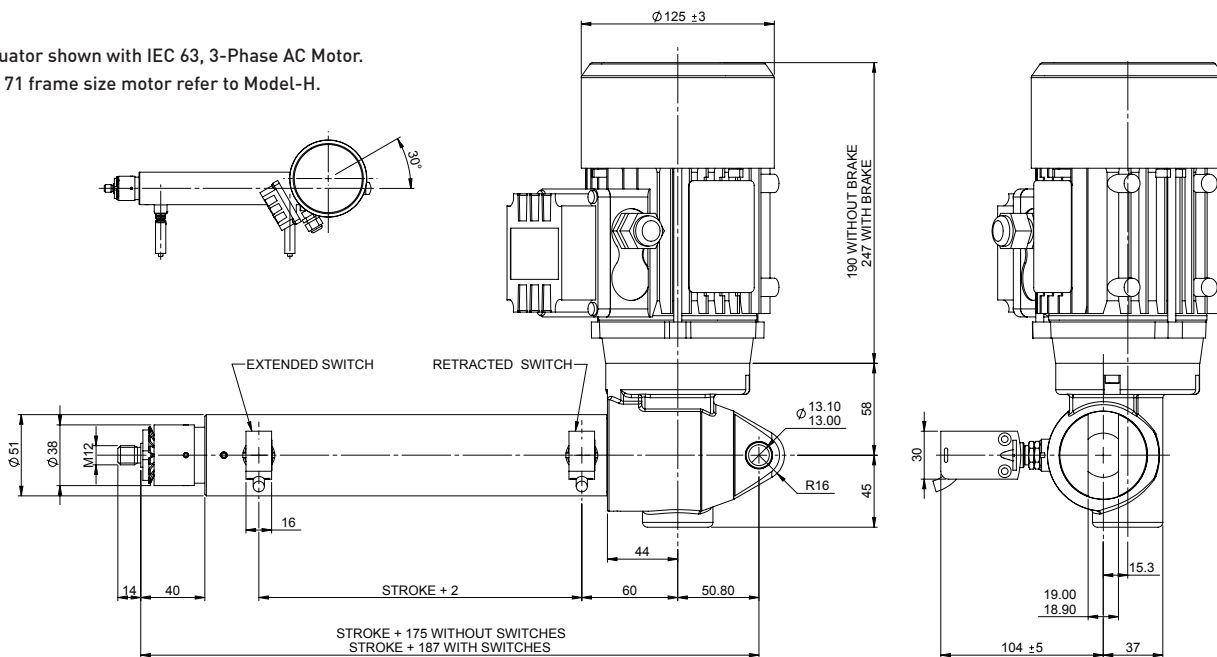

### General Performance

MODEL I (INTERMITTENT DUTY)					
Dynamic Capacity (kN)	10	5	5	5	2.5
Linear Speed (mm/min)	135	200	270	410	820
Motor Power (kW)	0.18	0.18	0.18	0.18	0.18
Motor Frame Size (IEC)	71	63	71	63	63
Motor Poles	6	4	6	2	2
Max Stroke - Compression (mm)	750	750	750	750	750
Max Stroke - Tension (mm)*	2000	2000	2000	2000	2000
Weight - no stroke (kg)	9				
Weight - per 100mm stroke (kg)	0.69				
Ambient Operating Temperature [°C]**	-10°C to +50°C				
Duty Cycle Rating	Up to 5 cycles per hour, 50 cycles per day. Up to 25% operating time per hour.				

Note: \* Longer strokes available on request, \*\* Consult Power Jacks to discuss hostile or hazardous environments.

### Motor Types and Options

ITEM	MOTOR TYPE		
	3 PHASE AC	1 PHASE AC	DC
Voltage	220 - 240/380 - 415VAC	220 - 240 VAC	24VDC
Motor Design	Induction	Single or Double Capacitor Designs	Permanent Magnet
Frame Type	IEC, 63C Face	IEC, 63C Face	IEC, 63C Face
Enclosure (std)	IP54	IP54	IP54

MOTOR OPTIONS			
Brake Type	3ph AC, 1ph AC or DC	1ph AC or DC	DC
Enclosure	IP55, 56, 65	IP55	IP55
Encoder	Available	Available	Available
Forced Ventilation	Available	-	Available
Other	Inverter Rated	-	12,48 VDC

### Control Options

DEVICE	OPTION 1	OPTION 2
Limit Switches	Electro-mechanical	Inductive proximity
Clutch	Friction Clutch on Ram	-
Encoder Type	Incremental	Absolute

### Mounting Options

FITTING	GEARBOX END	
	RAM END	GEARBOX END
Clevis	Y	Y
Fork	Y	N
Threaded	Y	N
Top Plate	Y	N
Trunnion	N	Y
Rod End	Y	N

### Related Accessories

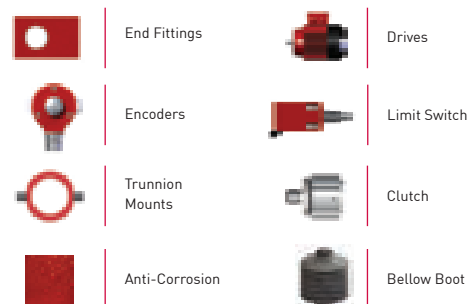

Actuator shown with IEC 63, 3-Phase AC Motor.  
For 71 frame size motor refer to Model-H.

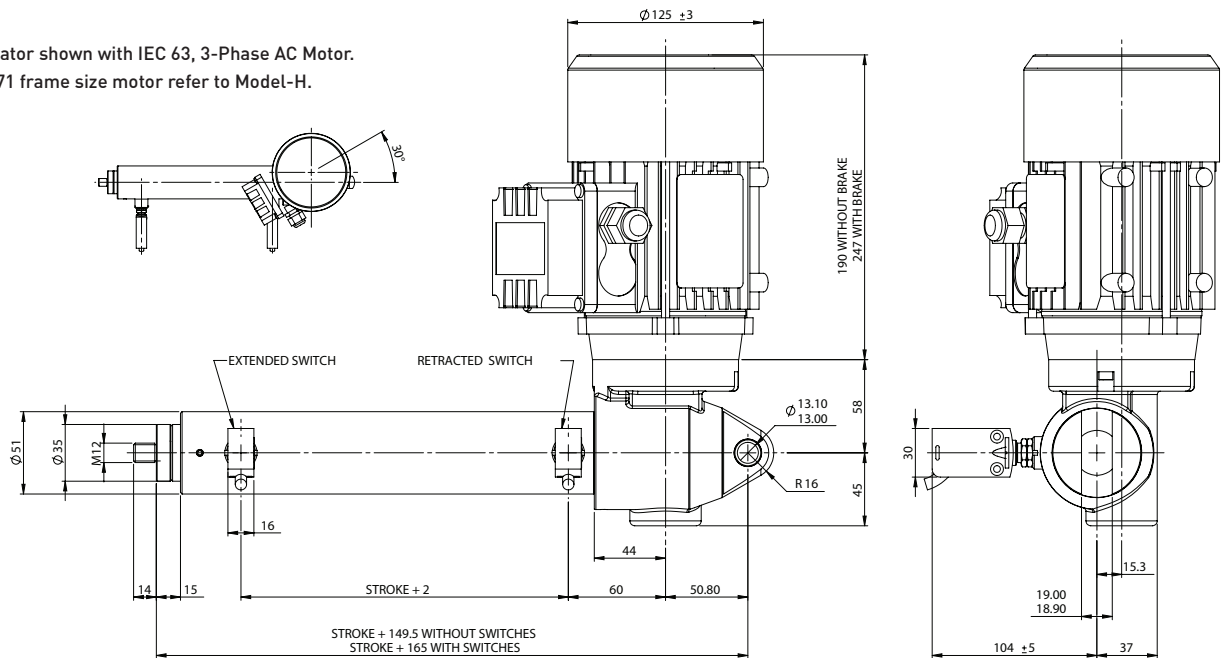

### General Performance

MODEL I (INTERMITTENT DUTY)					
Dynamic Capacity (kN)	10	5	5	5	2.5
Linear Speed (mm/min)	135	200	270	410	820
Motor Power (kW)	0.18	0.18	0.18	0.18	0.18
Motor Frame Size (IEC)	71	63	71	63	63
Motor Poles	6	4	6	2	2
Max Stroke - Compression (mm)	750	750	750	750	750
Max Stroke - Tension (mm)*	2000	2000	2000	2000	2000
Weight - no stroke (kg)	9				
Weight - per 100mm stroke (kg)	0.69				
Ambient Operating Temperature (°C)**	-10°C to +50°C				
Duty Cycle Rating	Up to 5 cycles per hour, 50 cycles per day. Up to 25% operating time per hour.				

**Note:** \* Longer strokes available on request, \*\* Consult Power Jacks to discuss hostile or hazardous environments.

### Motor Types and Options

MOTOR TYPE			
ITEM	3 PHASE AC	1 PHASE AC	DC
Voltage	220 - 240/380 - 415VAC	220 - 240 VAC	24VDC
Motor Design	Induction	Single or Double Capacitor Designs	Permanent Magnet
Frame Type	IEC, 63C Face	IEC, 63C Face	IEC, 63C Face
Enclosure (std)	IP54	IP54	IP54

MOTOR OPTIONS			
Brake Type	3ph AC, 1ph AC or DC	1ph AC or DC	DC
Enclosure	IP55, 56, 65	IP55	IP55
Encoder	Available	Available	Available
Forced Ventilation	Available	-	Available
Other	Inverter Rated	-	12,48 VDC

### Control Options

DEVICE	OPTION 1	OPTION 2
Limit Switches	Electro-mechanical	Inductive proximity
Clutch	Friction Clutch on Ram	-
Encoder Type	Incremental	Absolute

### Mounting Options

FITTING		
	RAM END	GEARBOX END
Clevis	Y	Y
Fork	Y	N
Threaded	Y	N
Top Plate	Y	N
Trunnion	N	Y
Rod End	Y	N

### Related Accessories

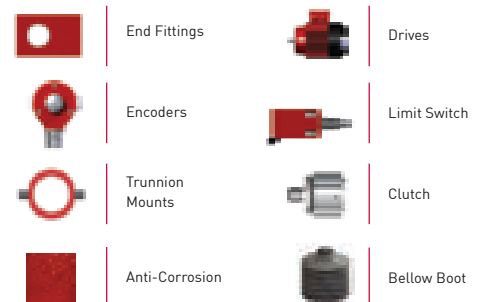

Actuator shown with IEC 63, 3-Phase AC Motor.  
For 71 frame size motor refer to Model-H.

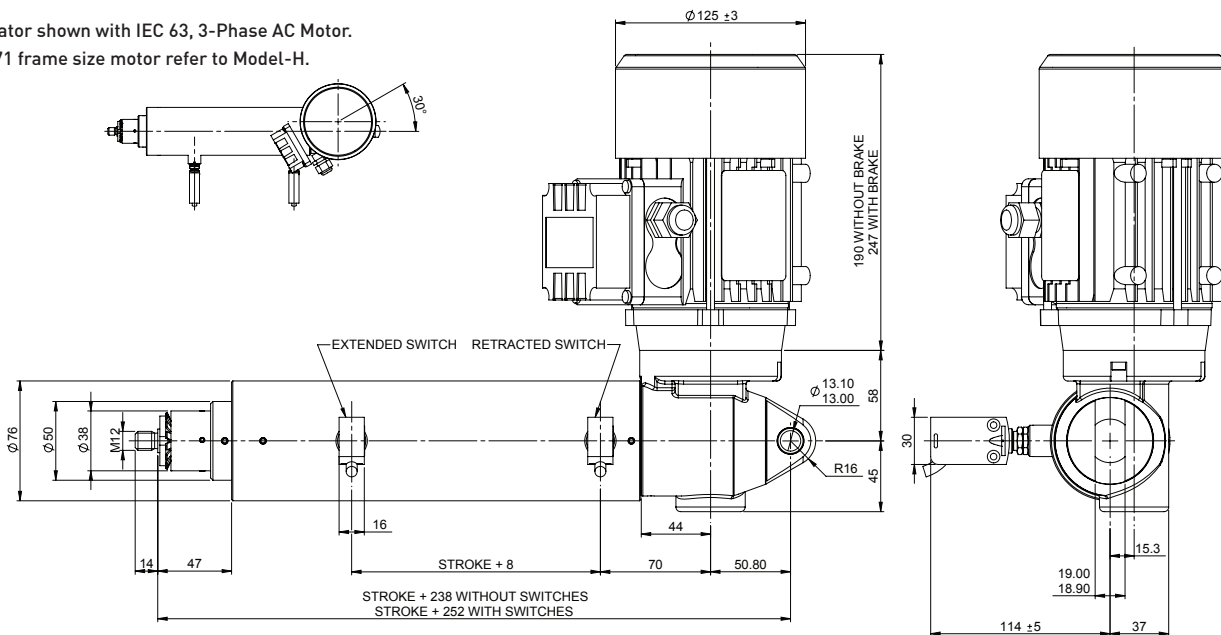

### General Performance

MODEL C (MEDIUM DUTY)					
Dynamic Capacity (kN)	10	10	10	5	2.5
Linear Speed (mm/min)	225	335	685	1370	2740
Motor Power (kW)	0.18	0.18	0.18	0.18	0.18
Motor Frame Size (IEC)	71	63	71	63	63
Motor Poles	6	4	2	2	2
Max Stroke - Compression (mm)	900	900	900	1250	1500
Max Stroke - Tension (mm)*	2000	2000	2000	2000	2000
Weight - no stroke (kg)	10				
Weight - per 100mm stroke (kg)	1.3				
Ambient Operating Temperature [°C]**	-10°C to +50°C				
Duty Cycle Rating	Up to 20 cycles per hour, 1000 cycles per day. Up to 50% operating time per hour.				

Note: \* Longer strokes available on request, \*\* Consult Power Jacks to discuss hostile or hazardous environments.

### Motor Types and Options

ITEM	MOTOR TYPE		
	3 PHASE AC	1 PHASE AC	DC
Voltage	220 - 240/380 - 415VAC	220 - 240 VAC	24VDC
Motor Design	Induction	Single or Double Capacitor Designs	Permanent Magnet
Frame Type	IEC, 63C Face	IEC, 63C Face	IEC, 63C Face
Enclosure (std)	IP54	IP54	IP54

	MOTOR OPTIONS		
	3ph AC, 1ph AC or DC	1ph AC or DC	DC
Brake Type	3ph AC, 1ph AC or DC	1ph AC or DC	DC
Enclosure	IP55, 56, 65	IP55	IP55
Encoder	Available	Available	Available
Forced Ventilation	Available	-	Available
Other	Inverter Rated	-	12,48 VDC

### Control Options

DEVICE	OPTION 1	OPTION 2
Limit Switches	Electro-mechanical	Inductive proximity
Clutch	Friction Clutch on Ram	-
Encoder Type	Incremental	Absolute

### Mounting Options

	FITTING	
	RAM END	GEARBOX END
Clevis	Y	Y
Fork	Y	N
Threaded	Y	N
Top Plate	Y	N
Trunnion	N	Y
Rod End	Y	N

### Related Accessories

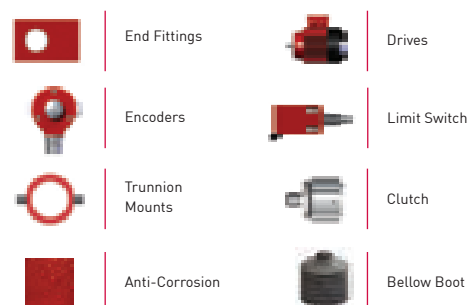



Actuator shown with IEC 63, 3-Phase AC Motor.  
For 71 frame size motor refer to Model-H.

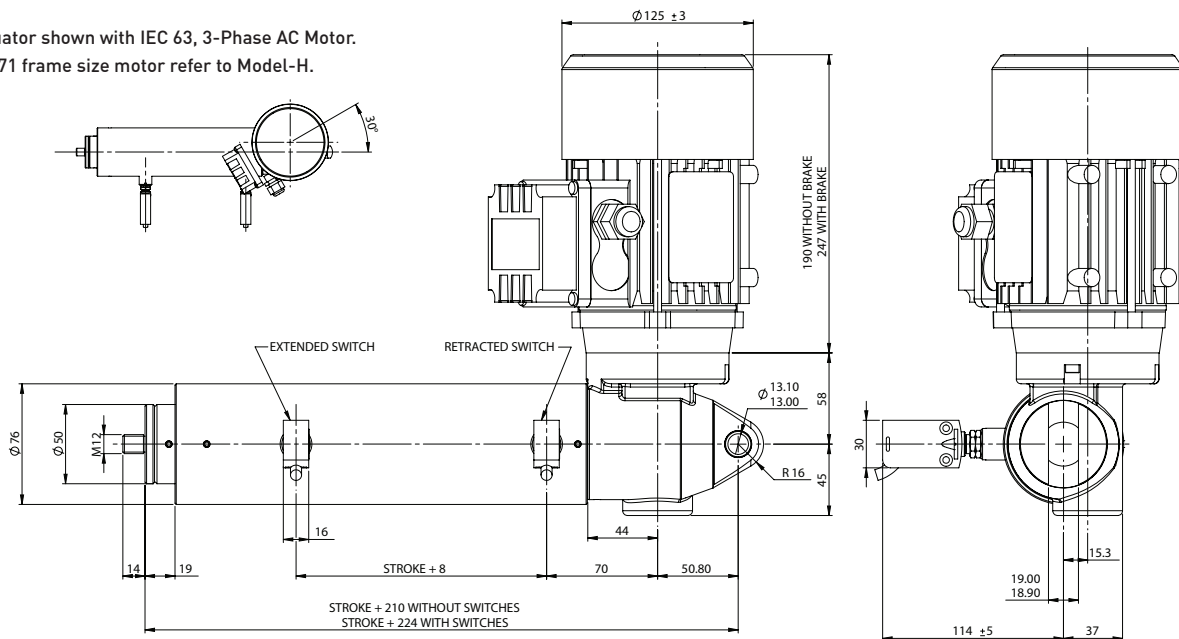

### General Performance

MODEL C (MEDIUM DUTY)					
Dynamic Capacity (kN)	10	10	10	5	2.5
Linear Speed (mm/min)	225	335	685	1370	2740
Motor Power (kW)	0.18	0.18	0.18	0.18	0.18
Motor Frame Size (IEC)	71	63	71	63	63
Motor Poles	6	4	2	2	2
Max Stroke - Compression (mm)	900	900	900	1250	1500
Max Stroke - Tension (mm)*	2000	2000	2000	2000	2000
Weight - no stroke (kg)	10				
Weight - per 100mm stroke (kg)	1.3				
Ambient Operating Temperature (°C)**	-10°C to +50°C				
Duty Cycle Rating	Up to 20 cycles per hour, 1000 cycles per day. Up to 50% operating time per hour.				

**Note:** \* Longer strokes available on request, \*\* Consult Power Jacks to discuss hostile or hazardous environments.

### Motor Types and Options

MOTOR TYPE			
ITEM	3 PHASE AC	1 PHASE AC	DC
Voltage	220 - 240/380 - 415VAC	220 - 240 VAC	24VDC
Motor Design	Induction	Single or Double Capacitor Designs	Permanent Magnet
Frame Type	IEC, 63C Face	IEC, 63C Face	IEC, 63C Face
Enclosure (std)	IP54	IP54	IP54

MOTOR OPTIONS			
Brake Type	3ph AC, 1ph AC or DC	1ph AC or DC	DC
Enclosure	IP55, 56, 65	IP55	IP55
Encoder	Available	Available	Available
Forced Ventilation	Available	-	Available
Other	Inverter Rated	-	12,48 VDC

### Control Options

DEVICE	OPTION 1	OPTION 2
Limit Switches	Electro-mechanical	Inductive proximity
Clutch	Friction Clutch on Ram	-
Encoder Type	Incremental	Absolute

### Mounting Options

FITTING	RAM END		GEARBOX END	
	Y	N	Y	N
Clevis	Y	N	Y	N
Fork	Y	N	N	N
Threaded	Y	N	N	N
Top Plate	Y	N	N	N
Trunnion	N	Y	Y	Y
Rod End	Y	N	N	N

### Related Accessories

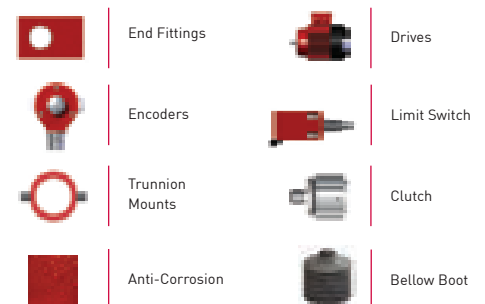

Actuator shown with IEC 71, 3-Phase AC Motor.

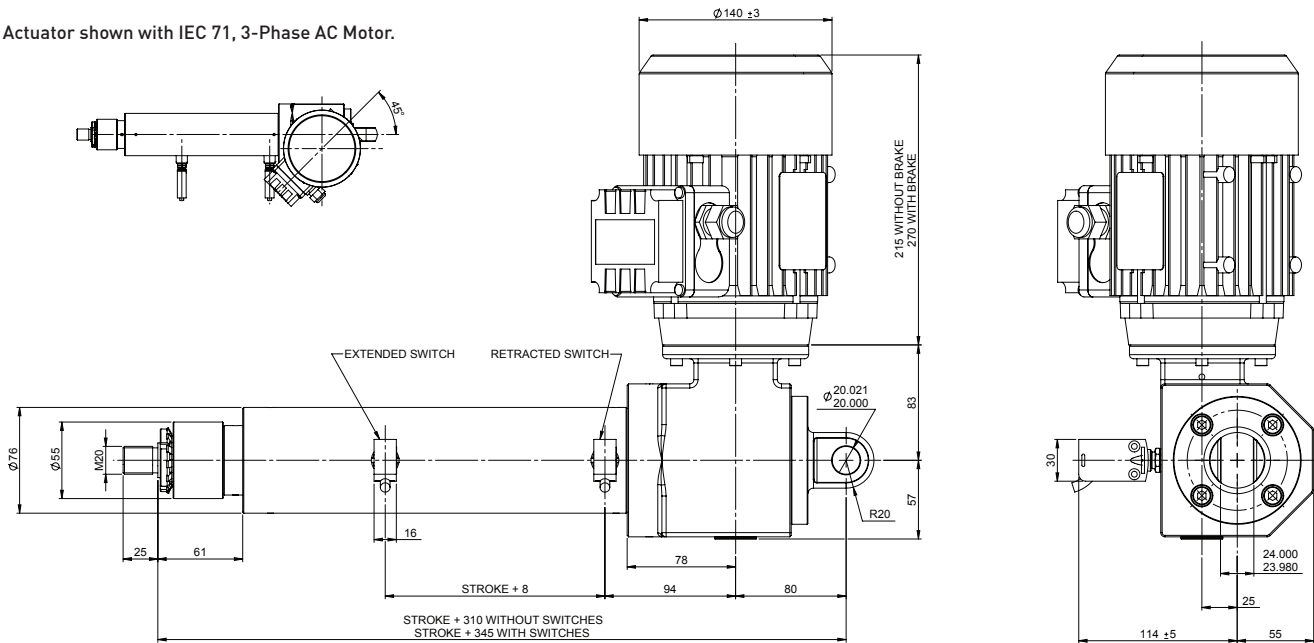

### General Performance

MODEL H (HIGH SPEED & MEDIUM DUTY)					
Dynamic Capacity (kN)	10	10	10	5	5
Linear Speed (mm/min)	900	1375	2755	1805	5510
Motor Power (kW)	0.25	0.37	0.55	0.25	0.55
Motor Frame Size (IEC)	71	71	71	71	71
Motor Poles	6	2	2	6	2
Max Stroke - Compression (mm)	900	900	900	1250	1250
Max Stroke - Tension (mm)*	2000	2000	2000	2000	2000
Weight - no stroke (kg)	12				
Weight - per 100mm stroke (kg)	1.3				
Ambient Operating Temperature [°C]**	-10°C to +50°C				
Duty Cycle Rating	Up to 20 cycles per hour, 1000 cycles per day. Up to 50% operating time per hour.				

Note: \* Longer strokes available on request, \*\* Consult Power Jacks to discuss hostile or hazardous environments.

### Motor Types and Options

MOTOR TYPE			
ITEM	3 PHASE AC	1 PHASE AC	DC
Voltage	220 - 240/380 - 415VAC	220 - 240 VAC	24VDC
Motor Design	Induction	Single or Double Capacitor Designs	Permanent Magnet
Frame Type	IEC, 63C Face	IEC, 63C Face	IEC, 63C Face
Enclosure (std)	IP54	IP54	IP54

MOTOR OPTIONS			
Brake Type	3ph AC, 1ph AC or DC	1ph AC or DC	DC
Enclosure	IP55, 56, 65	IP55	IP55
Encoder	Available	Available	Available
Forced Ventilation	Available	-	Available
Other	Inverter Rated	-	12,48 VDC

### Control Options

DEVICE	OPTION 1	OPTION 2
Limit Switches	Electro-mechanical	Inductive proximity
Clutch	Friction Clutch on Ram	-
Encoder Type	Incremental	Absolute

### Mounting Options

FITTING	RAM END		GEARBOX END	
	Y	N	Y	N
Clevis	Y	N	Y	N
Fork	Y	N	N	N
Threaded	Y	N	N	N
Top Plate	Y	N	N	N
Trunnion	N	Y	Y	Y
Rod End	Y	N	N	N

### Related Accessories

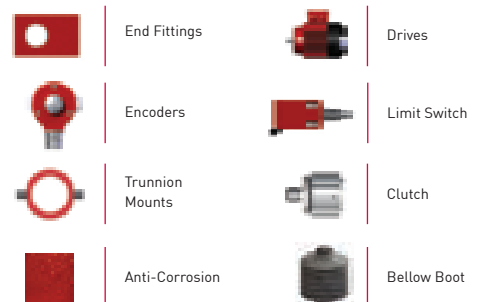

Actuator shown with IEC 71, 3-Phase AC Motor.

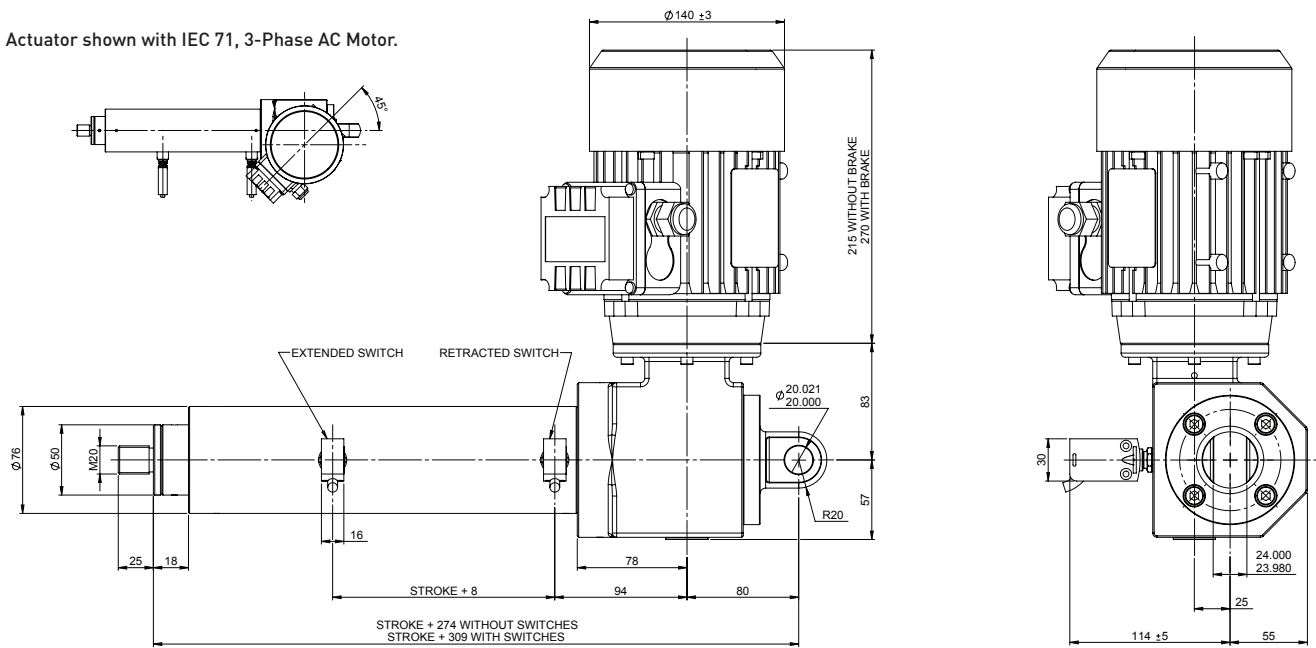

### General Performance

MODEL H (HIGH SPEED & MEDIUM DUTY)					
Dynamic Capacity (kN)	10	10	10	5	5
Linear Speed (mm/min)	900	1375	2755	1805	5510
Motor Power (kW)	0.25	0.37	0.55	0.25	0.55
Motor Frame Size (IEC)	71	71	71	71	71
Motor Poles	6	2	2	6	2
Max Stroke - Compression (mm)	900	900	900	1250	1250
Max Stroke - Tension (mm)*	2000	2000	2000	2000	2000
Weight - no stroke (kg)	12				
Weight - per 100mm stroke (kg)	1.3				
Ambient Operating Temperature (°C)**	-10°C to +50°C				
Duty Cycle Rating	Up to 20 cycles per hour, 1000 cycles per day. Up to 50% operating time per hour.				

**Note:** \* Longer strokes available on request, \*\* Consult Power Jacks to discuss hostile or hazardous environments.

### Motor Types and Options

MOTOR TYPE			
ITEM	3 PHASE AC	1 PHASE AC	DC
Voltage	220 - 240/380 - 415VAC	220 - 240 VAC	24VDC
Motor Design	Induction	Single or Double Capacitor Designs	Permanent Magnet
Frame Type	IEC, 63C Face	IEC, 63C Face	IEC, 63C Face
Enclosure (std)	IP54	IP54	IP54

MOTOR OPTIONS			
Brake Type	3ph AC, 1ph AC or DC	1ph AC or DC	DC
Enclosure	IP55, 56, 65	IP55	IP55
Encoder	Available	Available	Available
Forced Ventilation	Available	-	Available
Other	Inverter Rated	-	12,48 VDC

### Control Options

DEVICE	OPTION 1	OPTION 2
Limit Switches	Electro-mechanical	Inductive proximity
Clutch	Friction Clutch on Ram	-
Encoder Type	Incremental	Absolute

### Mounting Options

FITTING		
	RAM END	GEARBOX END
Clevis	Y	Y
Fork	Y	N
Threaded	Y	N
Top Plate	Y	N
Trunnion	N	Y
Rod End	Y	N

### Related Accessories

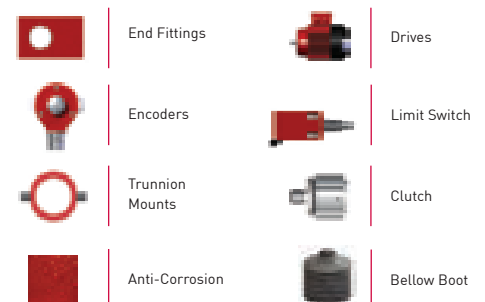

As standard, the units are available with 240V/415VAC 3-phase or 240VAC 1-phase or 24VDC motors, with or without a brake. The type of motors required is dependent on the customer's application. The motors are mounted to the actuator on an IEC 63C B14 Face Mounting.

MOTOR TYPE			
ITEM	3 PHASE	1 PHASE	DC
Voltage	220 - 240/380 - 415VAC	220 - 240 VAC	24VDC
Motor Design	Induction	Single or Double Capacitor Designs	Permanent Magnet
Frame Type	IEC (NEMA on request)	IEC (NEMA on request)	IEC (NEMA on request)
Enclosure (std)	IP54	IP54	IP54

Brake	3ph AC, 1ph AC or DC	1ph AC or DC	DC
Enclosure	IP55, 56, 65	IP55	IP55
Encoder	Available	Available	Available
Forced Ventilation	Available	-	Available
Other	Inverter Rated	-	12,48 VDC



### Standard 3-phase

**Key Features**  
 3 Phase, 50 Hz / 60Hz  
 220-240/380-415VAC  
 B14 Face Mounting  
 2-Pole (3000 rpm), 4-Pole (1500 rpm),  
 6-Pole (1000 rpm)  
 IEC Frame Sizes to 63-71

### Standard 3-phase with brake

**Key Features**  
 3 Phase, 50 Hz / 60Hz  
 220-240/380-415VAC  
 B14 Face Mounting  
 2-Pole (3000 rpm), 4-Pole (1500 rpm),  
 6-Pole (1000 rpm)  
 IEC Frame Sizes 63 to 71  
 High torque DC brake  
 rectifier: 230VAC, 50/60Hz  
 (others on request)

### Benefits

- High efficiency – low running costs
- Low noise levels
- High power factors
- High torque with smooth acceleration and low current
- Multi-mount versatility for mounting arrangement and terminal box position
- Aluminium construction for light weight and corrosion resistance
- Four position cable entry

## Wiring Diagram

3-Phase Motor Wiring Diagram  
 (Example-always check for exact motor used)

### Delta connection

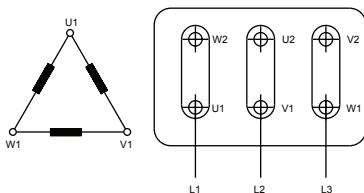

### Star connection

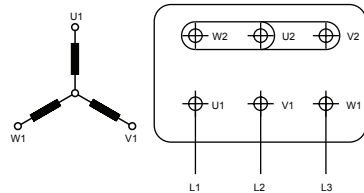

3-Phase Braked Motor Wiring Diagram  
 (Example-always check for exact motor used)

For brake motors with dc brake required at 230/400V 50Hz, the rectifier is directly connected to the motor terminal block as follows.

If using an inverter (frequency converter) then the brake must use a separate power supply to the rectifier.

### Delta connection

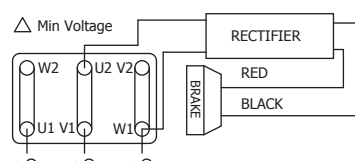

### Star connection

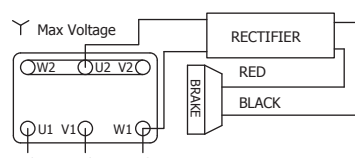

1-Phase Motor Wiring Diagram  
 (Example-always check for exact motor used)

### Single Capacitor

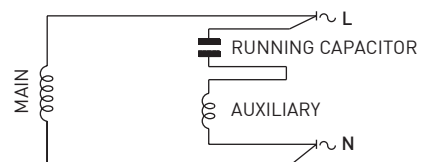

### Double Capacitor

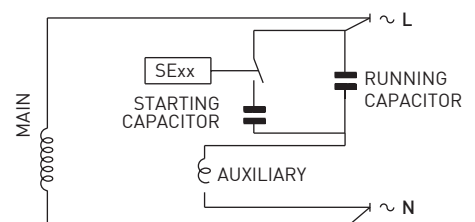

### Standard EMA Actuator Limit Switch

Our range of motion control devices allows you to safe guard the operation of you actuator system and ensures it operates within the specified parameters.

#### Standard Limit Switches

- Electro-Mechanical Switches
- Proximity Sensors (Inductive)
- Safety Rated Limit Switches
- Compact reduced height designs
- Threaded Barrel Mounting
- Flying cable or plug-in connector options
- Enclosures up to IP65 - IP67 available

#### Non Standard Limit Switches

- Other limit switches can be supplied to suit most applications.
- Different sizes, shape design and enclosure electro-mechanical limit switches
- Capacitive proximity sensor
- Bolt on Limit Switches
- Hazardous Area Rated electro-mechanical limit switch
- High or low temperature rated
- Enclosures up to IP68 available

For further details, consult Power Jacks

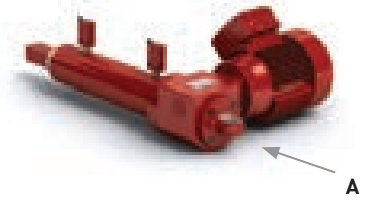

**View A**  
Showing Limit  
Switches Position 1



Electro-Mechanical  
Limit Switch



Proximity Sensor

## Electro-Mechanical Switch Specifications

Housing	Metal, compact housing, totally enclosed and sealed
Pre-cabled	2m PVC cable 5 x 0.75mm <sup>2</sup> (other cable lengths available on request)
Switch type	Single pole, 1 change-over, snap action
Max actuation speed	0.5 m/s
Mechanical durability	10 million operating cycles
Operation	-25°C +77°C
Storage	-40°C +70°C
Product conformity	IEC947-5-1
Enclosure	IP67
Operating characteristics	AC - 15; B300 (UE = 240V, I <sub>e</sub> = 1.5A)
	DC - 13; R300 (UE = 240V, I <sub>e</sub> = 0.1A)
Insulation voltage	U <sub>i</sub> = 300V

#### Notes:

- As standard 2 limit switches are mounted for end of travel positions. These switches are mounted in the same position radially on the actuators ram.
- More than 2 limit switches can be installed and limit switches can be individually mounted at different radial positions.
- Alternative switch mounting positions along the actuators ram are available on request.

#### View A

Alternative Limit Switch Mounting Orientations

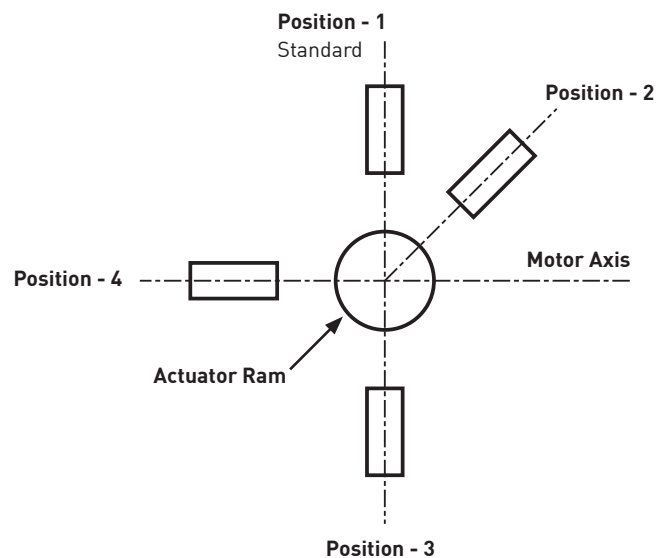

Encoders are mounted to an EMA Actuator either on the back of an electric motor (under cowling) or on the actuators gearbox opposite the motor.

**Absolute Encoders**

- Hollow or Solid shaft designs
- Multi-Turn
- SSI, 25-Bit, RS422
- Configurable interface
- Resolution up to 8192 steps x 8192 revolutions
- Enclosure Up to IP66 as standard

Other designs available on request

**Incremental Encoders**

- Hollow or Solid shaft designs
- Multi-Turn
- Signal lines from 1 to 8192
- RS422 or Push-pull output drivers
- Enclosure Up to IP66 as standard

Other designs available on request



Absolute

Incremental

**Absolute**

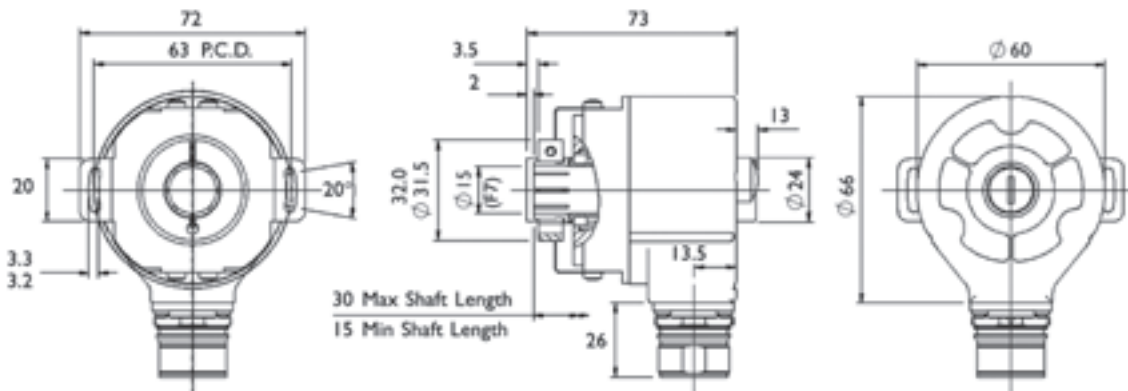

**Incremental**

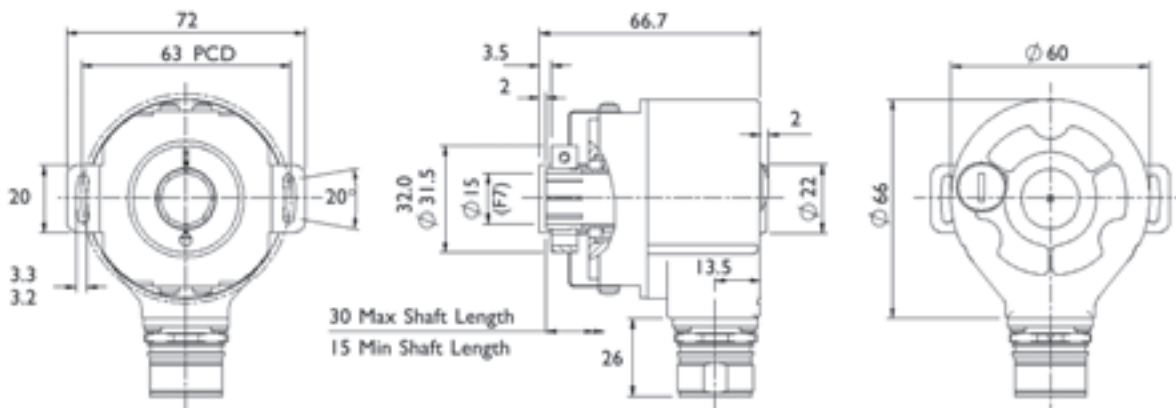

### Top Plate

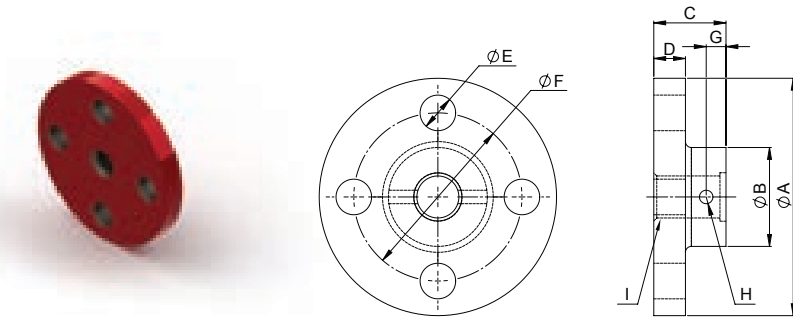

MODEL	I	C	H
ØA	Ø80	Ø80	Ø100
ØB	Ø30	Ø30	Ø40
C	24	24	31.5
D	10	10	12
ØE	Ø11	Ø11	Ø13.5
ØF (PCD)	Ø55	Ø55	Ø70
G	8	8	10
H	M6 x 1	M6 x 1	M8 x 1.25
I	M12 x 1.75	M12 x 1.75	M20 x 2.5
Weight (kg)	0.43	0.43	0.79

PCD = Pitch Circle Diameter.

### Clevis End

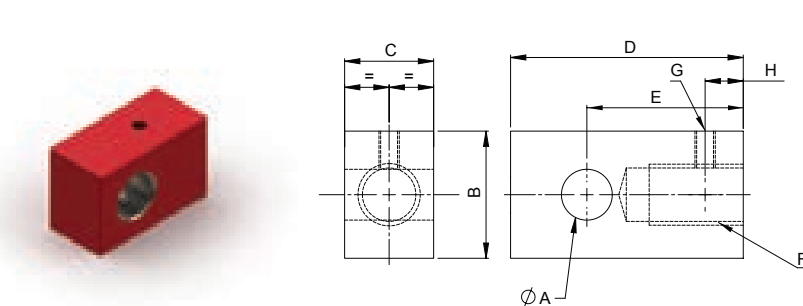

MODEL	I	C	H
ØA	Ø13	Ø13	Ø20
B	25	25	35
C	19	19	30
D	39	39	65
E	26	26	41
F	M12 x 1.75 16 Deep	M12 x 1.75 16 Deep	M20 x 2.5 27 Deep
G	M5 x 0.8	M5 x 0.8	M6 x 1
H	15	15	15
Weight (kg)	0.2	0.2	0.5

### Fork

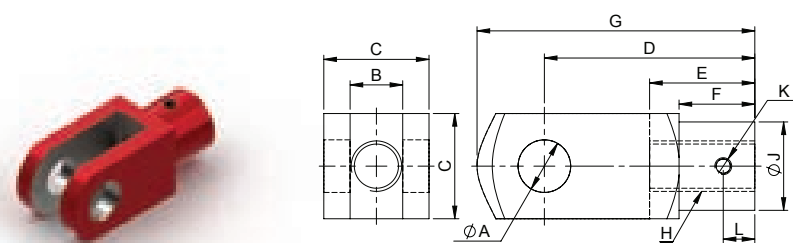

MODEL	I	C	H
ØA	Ø12	Ø12	Ø20
B	12	12	20
C	24	24	40
D	48	48	80
E	24	24	40
F	18	18	30
G	62	62	105
H	M12 x 1.75	M12 x 1.75	M20 x 2.5
ØJ	20	20	34
K	M6 x 1	M6 x 1	M8 x 1.25
L	10	10	10
Weight (kg)	0.12	0.12	0.55

### Rod End

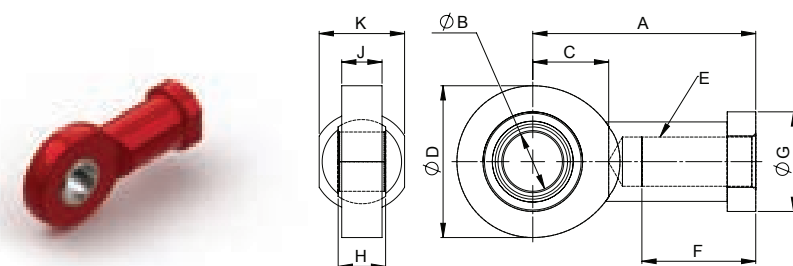

MODEL	I	C	H
A	50	50	77
ØB	12	12	20
C	18	18	27
ØD	34	34	53
E	M12 x 1.75	M12 x 1.75	M20 x 1.5
F	23	23	40
ØG	22	22	35
H	10	10	16
J	8	8	13
K	19	19	32
Weight (kg)	0.096	0.096	0.35

**Note:**

Lead screw threaded end made to suit rod end.

### Mounting

There are two possible ways of mounting the EMA actuator at the gearbox end. By means of bearing journals for trunnion mounting or clevis mount.

Special mounting arrangements available on request e.g. flange on outer tube of ram, or clamp point on ram.

### The Ram

A threaded end is standard on all models. Attachments are threaded on to the end of the ram and locked in place. The actuator can then be attached to the customers structure by a pinned or bolted connection depending on chosen model.

### Rear Clevis

Mount the actuator by attaching the desired bracket and pin to the clevis end. Verify that the ram attachment is aligned throughout the actuator stroke before connecting the ram. The ram attachment will either be pinned or bolted in place depending on chosen model.

### Trunnion Mount

Mount the actuator by attaching the desired bearings (or mounting feet) to the trunnion pins. Verify that the ram attachment is aligned throughout the actuator stroke before connecting the ram.

#### Trunnion Mount Note:

The position of mounting versions 3 and 4 is variable and should be specified by the customer at the time of ordering. (Dimension X). Also refer product code - "Trunnion Mounting Distance"

MODEL	I	C	H
ØS	11.99	14.99	14.99
	11.96	14.96	14.96
T	70	100	100
U	110	140	140

Mounting positions 5 and 6 are the same as 3 and 4 except they include trunnion feet.

#### Important Note:

Always ensure that clevis holes align correctly and that they allow for the correct angle of pivoting for the application before operating the actuator.

#### Important Note:

Side loads on the actuator ram should be avoided by ensuring that the load is guided. The load guide mechanism should resist the torque developed at the ram by the screw mechanism. A guided ram can be supplied on request, which utilises a keyway in the inner ram, eliminates the need for torsional restraint and therefore allows flexibility in the choice of end fitting. The desired mounting orientation will be determined when placing the order; this orientation must be maintained at installation.



Rear Clevis  
Version 1

Trunnion  
Version 3

Threaded End



Version 1

Version 2

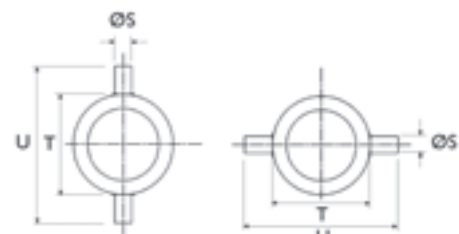

Version 3

Version 4

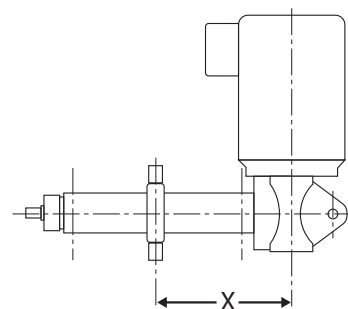

Actuator shown with trunnion mount version-3 and rear clevis version-1.





### Single Face Screw Jacks

---

- Metric Machine Screw Jacks 5kN to 2000kN
- Metric Ball Screw Jacks 10kN to 500kN
- Metric Stainless Steel Screw Jacks 10kN to 300kN
- Imperial (inch) Machine Screw Jacks 1/4Ton to 250Ton
- Imperial (inch) Ball Screw Jacks 1/2Ton to 50Ton
- Imperial (inch) Stainless Steel Screw Jacks 2Ton to 100Ton
- Special Designs Available Up To 3500kN



### EMA Linear Actuators

---

- Machine Screw & Ball Screw
- Low load, Medium Duty, High Speed
- Dynamic Load Ratings up to 10kN
- Linear Speeds up to 5500 mm/min
- 3-phase AC, 1-phase AC, and DC types
- Special Designs Available



### Rolaram Linear Actuators

---

- Ball Screw & Roller Screw
- High load, High Duty, High Speed
- Very High Accuracy
- Dynamic Load Ratings up to 400kN
- Linear Speeds up to 7000 mm/min
- 3-phase AC, 1-phase AC, and DC types
- True continuous duty / cycling actuator designs available
- Special Designs Available



### Spiracon Roller Screws

---

- High Dynamic Loads up to 1200kN
- High Efficiency
- High Positional Accuracy
- Long Life
- Low Maintenance
- Low Noise
- Robust Design for Harsh Environments
- Special Designs Available



### Neeter Drive Bevel Gearboxes

---

- 2-way, 3-way and 4-way Designs
- Solid Shaft & Hollow Shaft
- Motor Adaptors
- Gear Ratios 1:1, 1.5:1, 2:1, 3:1 and 4:1
- Torque Ratings up to 3000Nm
- Special Gear Ratios and Designs Available



## Lifting & Positioning Solutions

Power Jacks are specialist industrial engineers providing design, manufacturing and services of quality industrial lifting, positioning and load monitoring equipment.

Our products are supplied globally across many sectors including Industrial Automation, Energy, Transport, Defence and Civil.



Balmacassie Commercial Park  
Ellon, Aberdeenshire  
AB41 8BX  
Scotland (GB)  
Tel.: +44 (0)1358 285100  
[www.powerjacks.com](http://www.powerjacks.com)  
[sales@powerjacks.com](mailto:sales@powerjacks.com)  
EMA-PJEMAB-EN-01e



All information in this document is subject to change without notice. All rights reserved by Power Jacks Limited. May not be copied in whole or in part. ©Power Jacks Limited 2018, Aberdeenshire, Scotland, United Kingdom.

Follow Us Facebook LinkedIn Twitter