

# POWERJACKS

PRECISION ACTUATION

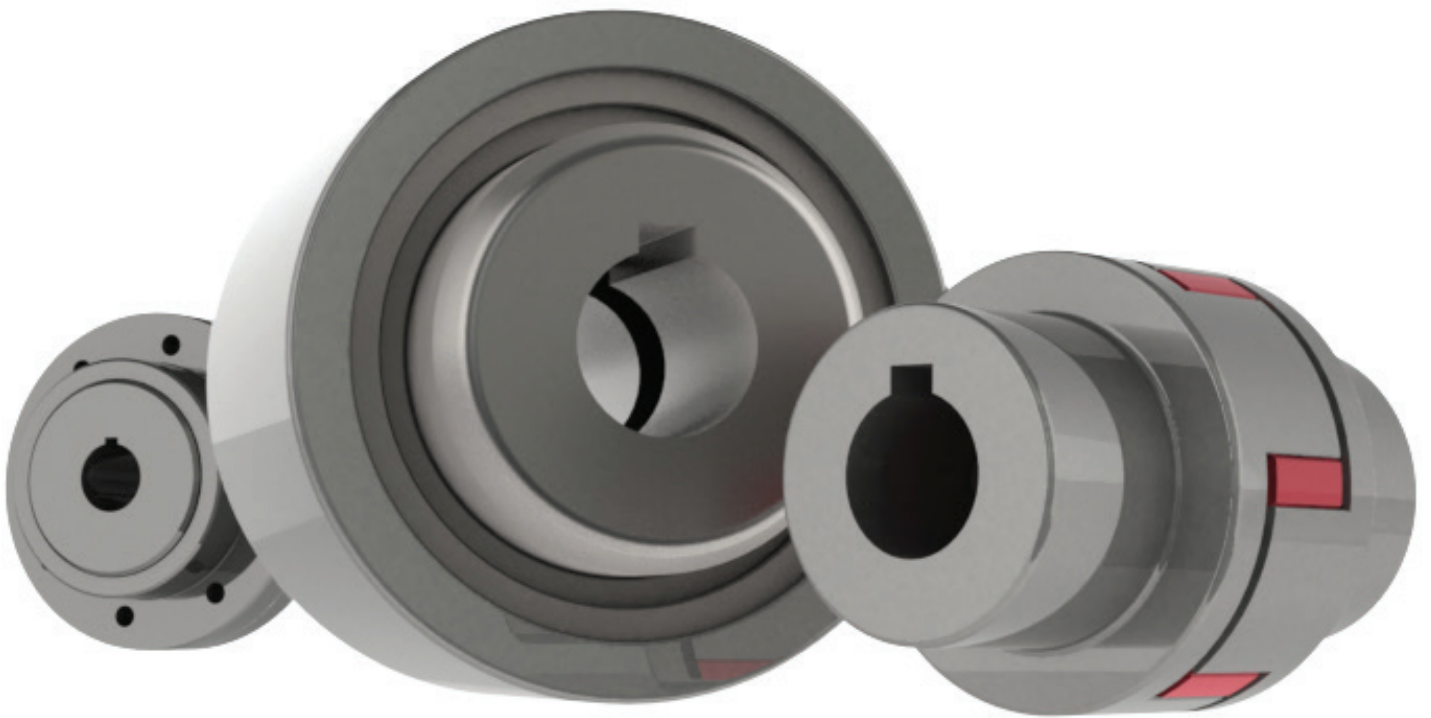

SYSTEM COMPONENTS  
COUPLINGS & DRIVE SHAFTS

**POWERJACKS**

**FULL RANGE OF COUPLING  
AND DRIVE SHAFTS SO YOU  
CAN BUILD COMPLETE  
JACKING SYSTEMS.**



# Capability



OUR EXPERTISE HAS BEEN BUILT ON A HISTORY OF MORE THAN 100 YEARS OF ENGINEERING, CRAFTSMANSHIP, VISIONARY DESIGN, QUALITY MANUFACTURE AND CUSTOMER CARE.



Power Jacks is a manufacturing/engineering company specialising in the design and manufacture of actuation, lifting and positioning solutions for applications in Industrial Automation, Energy, Defence, Medical, Transport, and the Civil Engineering sectors.

Headquartered near Aberdeen in the UK, the company is the UK's largest screw jack manufacturing facility, that uses the latest engineering technologies to deliver quality products (BS EN ISO 9001) that offer reliability, performance and economy.

Power Jacks deliver this high quality service in a safe (OHSAS 18001) and environmentally friendly (ISO 14001) working environment thanks to the highly trained, flexible and motivated teams that work throughout the business driving the company to higher levels of performance.

We know our customers demand our engineering expertise to help find a solution for their applications. We take pride in designing and delivering the best solution using standard or special designs that help improve your business.

Our Vision is to become the partner of choice for our products globally

Our Mission is to provide high quality lifting & positioning solutions.

# Global Reach

Power Jacks has local representation in 26 countries and supplies its products to more than 80 countries worldwide.



A global reach with a local service as we work closely with our customers to ensure the best solution for all their Electro-Mechanical solution applications.

- Headquarters & Factory
- Local Power Jacks Sales Offices
- Local Representative

Flexible Couplings

Selection of Coupling Type

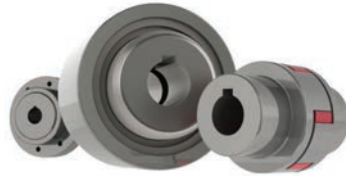

The selection of coupling type depends on the installation and the type of misalignment. The three main types of misalignment encountered are:-

1. Angular Misalignment is usually present to some extent on all applications, typical values 1° - 2°. Sometimes higher values are necessary.
2. Parallel (Radial) Misalignment is also nearly always present. A well aligned installation might have values below 0.25 mm.
3. Axial Misalignment (End Float) sometimes caused by thermal expansion or as a result of machine design.

Other considerations include:

- Backlash Free Couplings are either one part couplings or have bolted joints. These are effective for precise positioning and to avoid wear on reversing drives.
- Torsional rigidity of couplings depends on the joining method. Types with rubber or plastic elements can be considered as torsionally soft and will have an amount of twist at rated torque.

Procedure:

1. Decide if the coupling should be torsionally soft or rigid.
2. Consider whether a small amount of backlash is acceptable.
3. Calculate the required coupling torque.
4. Make a provisional selection.
5. Check that the coupling's maximum speed is sufficient.
6. Check that the coupling's dimensions are acceptable.
7. Contact Power Jacks with your order or technical enquiry

Selection of Coupling Size:

$$\text{Coupling Torque, T(Nm)} = \frac{9550 * \text{Power Transmitted (kW)} * S}{\text{RPM}}$$

where S = Service Factor - dependant on drive conditions (refer to each coupling) Select the coupling which is rated above the calculated torque. If a brake is present in the system the coupling should be based on either the brake torque or the transmitted torque whichever is greater.

Note

1. Maximum misalignment values are extremes and should not be combined. As operating misalignment approaches the maximum, torque and power ratings should be reduced to maintain life.
2. Gear couplings accommodate parallel misalignment by converting it to angular misalignment at the gear meshes in the flexible halves of the coupling.
3. The maximum axial misalignment values apply when the coupling is aligned. If axial misalignment greater than the listed maximum is required, consult Power Jacks.
4. The inertia values includes shafts through the bores.
5. When ordering please quote the coupling size and type, specify the bore and keyway sizes, and advise if puller holes or set-screws are required.
6. For maximum performance, the actuators, shafts, Gearboxes and motor should be carefully aligned.
7. Imperial couplings on request.

Keyways	Metric	Imperial
Standard Bores	B.S. 4500 1969 H7	B.S. 1916 Part 1 1953 K7
Standard Keyways	B.S. 4235 Part 1 1967 P9	B.S. 46 Part 1 1958

### Jaw Type Flexible Coupling

- Curved jaw design.
- No need for lubrication.
- Quick and simple to install.
- Reliable, rugged and compact.
- Smooth, silent action.
- High power transmission density.
- 4 Standard spider types available.
- Elastomeric element resistant to heat (-40°C to +90°C), grease, oil and chemical agents.
- Hubs in aluminium and sintered iron.

Size		14	19/24	24/30	28/38	38/45	42/55	48/60	55/70	65/75	75/90	90/100	100/110
Torque (Nm)	Nominal, T <sub>kn</sub>	P	10	35	95	190	265	310	375	425	975	2400	3300
	Max T <sub>kmax</sub>	P	20	70	190	380	530	620	750	850	1950	4800	6600
	Vibrating T <sub>kw</sub> (10Hz)	P	2.6	9	25	49	69	81	93	111	254	624	858
Misalignment Valves	Axial (mm)	P	1.2	1.4	1.5	1.8	2	2.1	2.2	2.6	3	3.4	3.8
	Angular (deg)	P	0.9	0.9	0.9	1	1	1.1	1.1	1.2	1.2	1.2	1.2
	Radial (mm)	P	0.2	0.22	0.25	0.28	0.32	0.36	0.38	0.42	0.48	0.5	0.52
Speed	Max (rpm)	P	14000	10600	8500	7100	6000	5600	4750	4250	3550	2800	2500

**Note** All couplings use 92 Shore elastomeric element (white) as standard. 80, 98 and 95 available on request.  
 Maximum torque must not be exceeded during start-up operation.  
 More accurate alignment will increase coupling life and reduce vibration. Dimensions "E" and "L" must be observed.  
 P = Consult Power Jacks for more details.

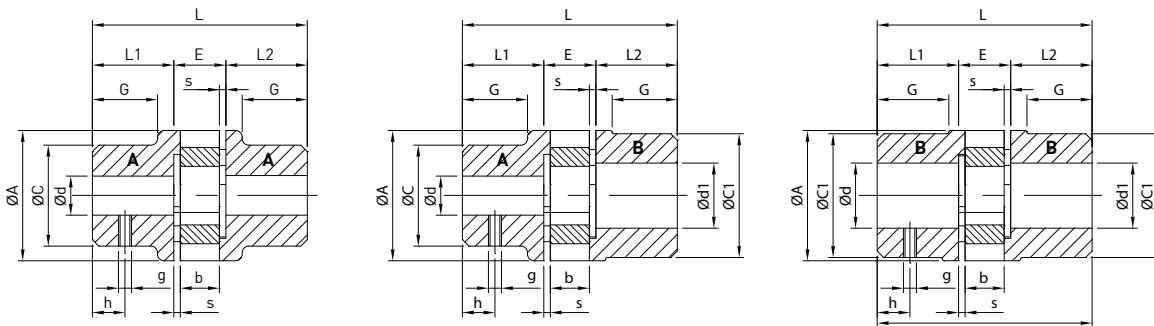

Type	Hub 'A'			Hub 'B'			Dimensions (mm)														Weight kg
	Pre Bore	Min Bore	Max Bore	Pre Bore	Min Bore	Max Bore	A	C	C1	L	L1& L2	E	s	b	G	F	g	h			
<b>Aluminium Hub Couplings</b>																					
19/24	6	6	19	18	20	24	40	31	38	66	25	16	2	12	20	18	M5	10	0.11		
24/30	6	8	24	22	25	30	55	39	48	78	30	18	2	14	24	27	M5	10	0.24		
28/38	9	10	28	26	30	38	65	46	61	90	35	20	2.5	15	28	30	M6	15	0.42		
38/45	12	14	38	36	40	45	80	64	75	114	45	24	3	18	38	38	M6	15	0.86		
<b>Cast Iron Hub Couplings</b>																					
19/24	-	-	-	-	6	24	40	-	40	66	25	16	2	12	-	18	M5	10	0.34		
24/30	-	-	-	-	8	32	55	-	55	78	30	18	2	14	-	27	M5	10	0.9		
28/38	-	-	-	-	10	38	65	-	65	90	35	20	2.5	15	-	30	M6	15	1.5		
38/45	-	14	38	-	40	45	80	66	78	114	45	24	3	18	37	38	M8	15	2.35		
42/55	-	16	42	-	45	55	95	75	93	126	50	26	3	20	40	46	M8	20	3.55		
48/60	-	19	48	-	50	60	105	85	103	140	56	28	3.5	21	45	51	M8	20	4.85		
55/70	-	22	55	53	60	70	120	98	118	160	65	30	4	22	52	60	M10	20	7.4		
65/75	-	25	65	63	70	75	135	115	133	185	75	35	4.5	26	61	68	M10	20	10.8		
75/90	-	30	75	73	80	90	160	135	158	210	85	40	5	30	69	80	M10	25	17.7		
90/100	-	-	-	-	45	100	200	-	170	245	100	45	5.5	34	81	100	M10	25	29.6		
100/110	-	-	-	-	45	110	225	-	180	270	110	50	6	38	89	113	M12	30	39		

**Note** Weight of min. bored coupling with standard A/B hub combination. All couplings metric bored and keyed as standard.  
 Consult Power Jacks for standard bore sizes and specials.

**Service Factor**  $S = Ft * Fz * Fs$

Temperature (°C)	-30°C to +30°C	40°C	60°C	80°C
Temperature Factor (Ft)	1	1.2	1.4	1.8

Starts/Day	0 to 10	101 to 200	201 to 400	401 to 800
Temperature Factor (Ft)	1	1.2	1.4	1.8
Shock Type	None	Light	Medium	High
Shock Factor (Fs)	1	1.2	1.8	2.5

### Flexible Spacer Couplings (Self-Supporting Drive Shafts)

- Compact, light, robust, safe in operation, long service life.
- Two identical hubs and one flexible element.
- Hubs of high tensile steel.
- Large permissible bores, various hub lengths.
- Driving dogs have smooth surface, high durability.
- Generously proportioned compression-stressed flexible inserts.
- Damps vibrations and shocks, compensates for axial, radial and angular misalignment.

#### Elastomeric Element features:

- Inserts made of "90 Shore A" Polyurethane (G) as standard or tough "55 Shore D" Hytrel (H).
- Operating temperature range: -40°C to +80°C as standard
- Elastomeric element is resistant to oil and grease.

#### Coupling Performance

Type	B-G			B-H-G			Max Speed N <sub>max</sub> (rpm) Elastomeric Element
Size	Nominal Torque T <sub>KN</sub> (Nm)	Maximum Torque T <sub>Kmax</sub> (Nm)	Torsional Angle (deg) at T <sub>KN</sub>	Nominal Torque T <sub>KN</sub> (Nm)	Maximum Torque T <sub>Kmax</sub> (Nm)	Torsional Angle (deg) at T <sub>KN</sub>	
72	32	64	4	45	80	2.5	10000
76	63	125	4	90	125	2.5	9000
98	125	250	4	175	280	2.5	7500
120	250	500	4	350	560	2.5	6000
138	400	800	4	560	900	2.5	5000
165	600	1200	4	850	1700	2.5	4000
185	1000	2000	4	1400	2800	2.5	3600

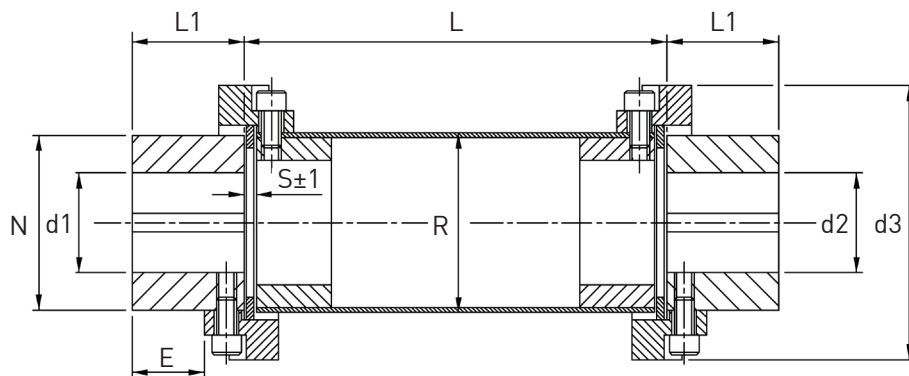

#### Coupling Dimensions

Size	d min (d1, d2)	d max (d1, d2)	d3	E	L1	N	R	S +/- 1	Model	L (minimum)
72	9	30	72	14	28	50	45	6	CF - B - (H) - 72 - G - L = *	100
76	12	30	76	16	30	50	45	6	CF - B - (H) - 76 - G - L = *	100
98	12	38	98	24	42	61	60	6	CF - B - (H) - 98 - G - L = *	100
120	15	48	120	28	50	71	70	6	CF - B - (H) - 120 - G - L = *	100
138	15	55	138	30	55	86	85	6	CF - B - (H) - 138 - G - L = *	140
165	20	65	165	36	65	100	100	8	CF - B - (H) - 165 - G - L = *	180
185	30	80	185	45	80	115	115	10	CF - B - (H) - 185 - G - L = *	180

\* Insert length, L here in millimetres.

#### Misalignment

Element Type	Radial (mm)	Axial (mm)	Angular (deg)
B-Standard	0.5	+/- 1	1
H-Hytrel	0.25	+/- 1	0.5

#### Note

The best possible alignment will result in the best coupling performance.

#### Service Factor

The service factor must be chosen according to working conditions between 1 (light duty) and 3 (arduous duty).

#### Critical Speed & Spacer length

Spacer coupling lengths can be provided up to a maximum of 6m depending on rotational speed. For advice on the critical speed of a given coupling consult Power Jacks.

## Steel Gear Couplings

### Continuous Sleeve Steel Gear Coupling

- Vari-crown tooth form for improved torque transmission and longer life.
- Strong compact design.
- High transmittable torque ratings.
- Low inertia and high maximum speeds.
- Steel reinforced high misalignment seals.
- Spacer couplings available on request.

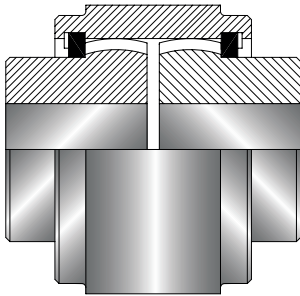

#### Full-Flex Gear Coupling

Two flexible hubs and sleeve assembly. Accommodates angular, parallel and axial misalignments.

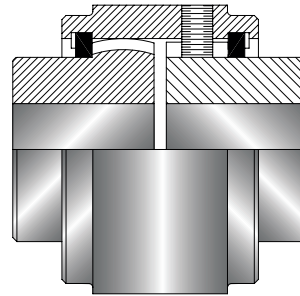

#### Flex-Rigid Gear Coupling

Flexible and rigid hub assembly. The flexible hub is standard and the rigid hub is splined into the sleeve. Accommodates angular and axial misalignment only.

### Flanged Sleeve Steel Gear Coupling

- High transmittable torque ratings and high maximum speeds.
- Accommodates angular, parallel and axial misalignment.
- Strong forged steel hubs and sleeves.
- Vari-crown tooth form for improved torque transmission and longer life.
- Several mounting options available by reversing the hubs.
- Spacer gear couplings available. Consult Power Jacks

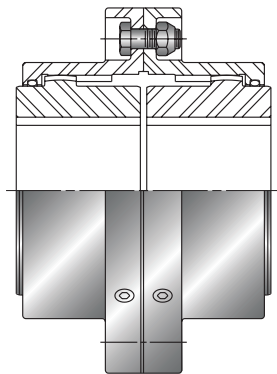

#### Full-Flex Gear Coupling

Two flexible hubs and sleeve assembly. Accommodates angular, parallel and axial misalignments.

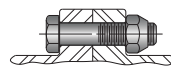

Exposed bolt design also available.

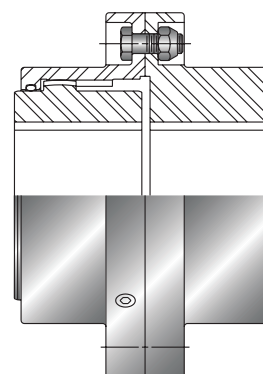

#### Flex-Rigid Gear Coupling

Flexible and rigid hub assembly. Accommodates angular and axial misalignment only.

## Service Factors for Gear Couplings

Nature of Load on Unit	Uniform	Light Shock	Medium Shock	Heavy Shock
Service Factor, S	1.0	1.25	1.5	2.0

### Note

1. All dimensions in millimetres.
2. These couplings are designed for grease lubrication. A list of suggested lubricants and quantities is detailed in the installation manual supplied with each full coupling.
3. Where a coupling is exposed to sustained temperatures above 100°C (212°F) a coupling with high temperature seals must be used, consult Power Jacks Ltd.

Steel Gear Couplings - Continuous Sleeve

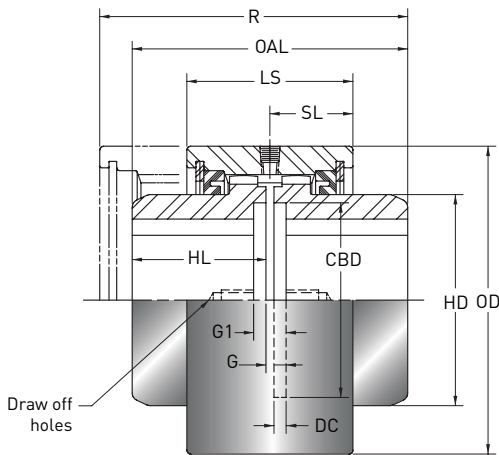

Full-Flex Gear Coupling

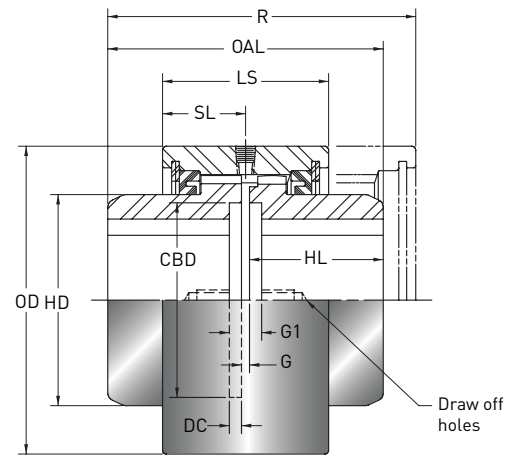

Flex-Rigid Gear Coupling

Coupling Size and Type		Full-Flex	CFF022	CFF038	CFF050	CFF065	CFF075	CFF090	CFF100	CFF115
		Flex-Rigid	CFR022	CFR038	CFR050	CFR065	CFR075	CFR090	CFR100	CFR115
Rated Torque (Nm)			285	854	2278	3417	5695	9967	14238	20787
Rated Power (kW/100 rpm)			3	8.9	23.8	35.8	59.6	104.4	149	217.7
Maximum Speed Unbalanced * (rpm)			6000	5000	4200	3750	3000	2800	2400	2200
Full Flex	Maximum Misalignment	Parallel	0.13	0.18	0.18	0.25	0.30	0.30	0.18	0.18
		Angular	1°	1°	1°	1°	1°	1°	1°	1°
		Axial (+/-)	0.3	0.3	0.3	0.6	0.6	0.6	0.6	0.6
Flex Rigid	Maximum Misalignment	Parallel	0.5°	0.5°	0.5°	0.5°	0.5°	0.5°	0.5°	0.5°
		Angular	0.3	0.3	0.3	0.6	0.6	0.6	0.6	0.6
Inertia (kg m <sup>2</sup> )			0.002	0.004	0.010	0.022	0.053	0.112	0.225	0.376
Weight (Rough Bore) (kg)			2.3	3.6	5.9	9.1	15	29	41	57
Maximum	Bore		31	42	56	70	84	97	111	130
	Keyway (b x h)		8 x 7	12 x 8	16 x 10	20 x 12	22 x 14	28 x 16	28 x 16	32 x 18
Rough Bore			11	15	18	22	30	32	44	60
DD			84	95	121	140	168	191	222	241
HD			51	60	83	100	121	137	159	184
HL			38	46	52	57	67	108	111	127
G			3	3	3	6	6	6	6	6
G1			10	13	13	19	19	19	19	19
OAL			80	95	108	121	140	222	229	260
R			95	117	124	145	175	235	241	264
LS			51	64	65	78	95	102	118	124
DC			3	5	5	6	6	6	6	6
CBD			49	57	76	95	121	140	165	184
SL			25	32	33	39	48	51	59	62

**Note** \*Balanced speed approximately 3 times higher. Draw off holes are optional, consult Power Jacks. All dimensions in millimetres.

**Note**

1. Dimension 'R' and 'CAC' are the clearance required to align the coupling when installing.



Steel Gear Couplings - Flanged Sleeve

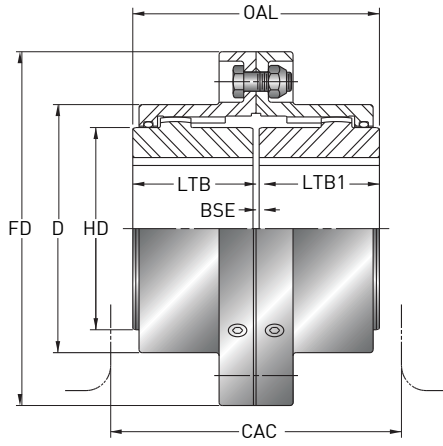

Full-Flex Gear Coupling

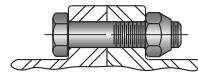

Exposed bolt design also available.

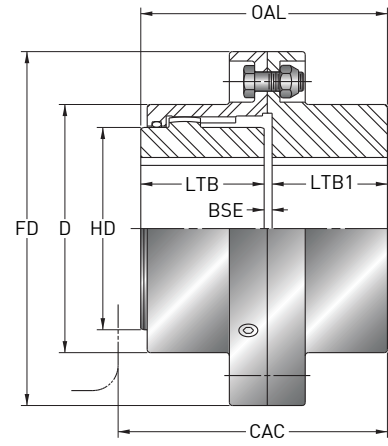

Flex-Rigid Gear Coupling

Coupling Size and Type		Full-Flex	FFF022	FFF038	FFF050	FFF065	FFF075	FFF090	FFF100
		Full-Rigid	FFR022	FFR038	FFR050	FFR065	FFR075	FFR090	FFR100
Rated Torque (Nm)			859	2136	3560	6407	10679	17086	24917
Rated Power (kW/100 rpm)			8.9	22.3	37.3	67.1	111.9	179	261
Maximum Speed Unbalanced * (rpm)			6000	5500	5000	4400	4000	3500	3000
Full Flex	Maximum Misalignment	Parallel	1.4	1.5	2.2	2.7	2.9	3.3	3.8
		Angular	3°	3°	3°	3°	3°	3°	3°
		Axial (per hub)	1.5	1.5	1.5	2.2	2.2	2.2	3.3
Full Rigid	Maximum Misalignment	Angular	1.5°	1.5°	1.5°	1.5°	1.5°	1.5°	1.5°
		Axial (per hub)	1.5	1.5	1.5	2.2	2.2	2.2	3.3
Inertia (kg m <sup>2</sup> )		Full Flex	0.006	0.019	0.044	0.100	0.192	0.435	0.80
		Flex Rigid	0.006	0.020	0.044	0.106	0.203	0.446	0.831
Weight (Rough Bore) (kg)		Full Flex	4	9	15	25	36	59	86
		Flex Rigid	4	8	15	25	39	61	89
Maximum (Flexible Ends)	Bore		42	56	73	88	107	124	147
	Keyway (b x h)		12 x 8	16 x 10	20 x 12	25 x 14	28 x 16	32 x 18	36 x 20
Maximum (Rigid Ends)	Bore		56	76	95	114	134	150	176
	Keyway (b x h)		16 x 10	20 x 12	25 x 14	32 x 18	36 x 20	36 x 20	45 x 25
Rough Bore		FFF	11	18	24	22	37	46	62
		FFR	Solid with Centre						
OAL			89	102	127	159	187	219	248
FD			116	152	178	213	240	279	318
D			78	101	125	150	176	201	235
HD			59	76	102	118	143	165	191
LBT			43	49	62	77	91	106	121
LTB 1			40	47	58	74	87	101	113
BSE	FFF		3	3	3	5	5	6	6
	FFR		4	4	4	5	5	6	8
OAL		FFF	89	102	127	159	187	219	248
		FFR	87	100	124	156	183	213	241
CAC		FFF	106	121	152	181	207	238	260
		FFR	95	109	137	167	192	222	248
Flange Thickness per Hub			14	19	19	22.5	22.5	29	29

**Note** \*Balanced speed approximately 3 times higher. Draw off holes are optional, consult Power Jacks. All dimensions in millimetres.

## Solid Drive Shafts



There are three standard drive shaft sizes offered by Power Jacks with ends machined to suit screw jack system couplings however drive shafts can be supplied to customer sizes with specific end designs

Standard Drive Shafts	Rated Torque (Nm)	Rated Angle of Twist per Metre (Degrees)
20mm Diameter	85	4
30mm Diameter	285	2.6
40mm Diameter	675	2

### Note

1. For other drive shaft types and sizes consult Power Jacks Ltd.
2. For detailed analysis consult Power Jacks Ltd.
3. Dimensions subject to change without notice.

### Select Drive Shaft Diameter

Select a standard drive shaft from the drive shaft table and check its torque rating and angle of twist rating against the application requirements.

If Transmitted Torque (Nm) < Maximum Drive Shaft Torque (Nm)

&

If Acceptable Angle of Twist (Deg.) for shaft length < Rated Angle of Twist for Drive Shaft (Deg.)

Then drive shaft diameter selected is acceptable.

### Shaft Check Drive Shaft Critical Speed

For the unsupported shaft length calculate the drive shaft critical speed for the support conditions required.

If Shaft Speed (rpm) < Drive Shaft Critical Speed (rpm) then drive shaft selection and configuration is acceptable.

### Plummer Block Selection

If the drive shaft selected is not suitable due to the critical speed reduce the unsupported drive shaft length using plummer blocks. e.g. one plummer block at each end of the drive shaft and one in the middle, reducing the unsupported length to half the total drive shaft length.

Select a plummer block from the table relating to the appropriate shaft diameter size.

Re-calculate the critical speed for the new unsupported length and check for acceptability.

If space constraints restrict the number of plummer blocks and the drive shaft fails on the critical speed try increasing the shaft diameter to the next size up or consult Power Jacks for detailed analysis.

### Note

1. For other shaft and plummer block sizes and styles consult Power Jacks Ltd.
2. For detailed shaft analysis and selection consult Power Jacks Ltd.

Solid Drive Shafts

Drive Shaft Critical Speed Factors,  $F_{dcs}$

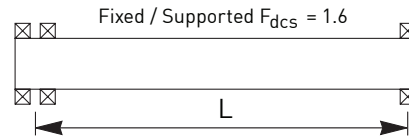
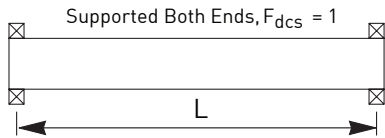

$$\text{Allowable Drive Shaft Speed (rpm)} = \frac{\text{Critical Speed (rpm) for Unsupported Length "L" (from chart below)}}{\text{Unsupported Length "L" (from chart below)}} \times F_{dcs}$$

Drive Shaft Critical Speed Graph  
(Shaft Whirling)

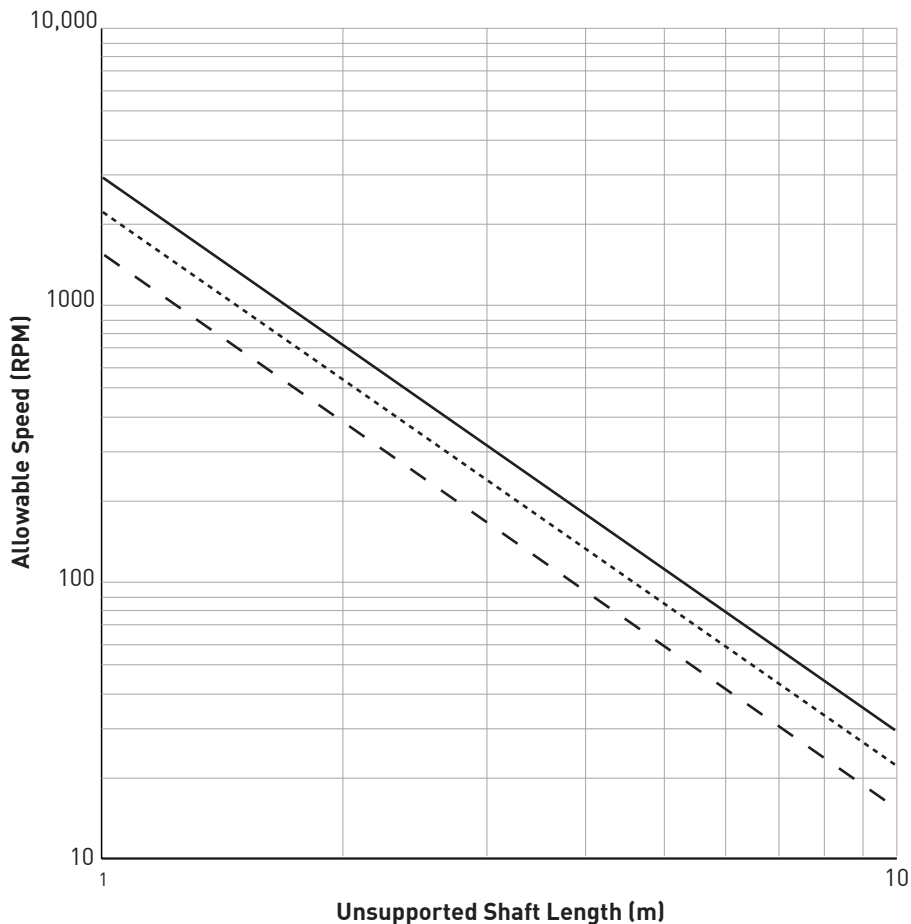

Based on simply supported both ends and 70% of the critical speed.  
(The factor of safety allows for couplings and slight misalignment)

--- 20mm Diameter    ..... 30 mm Diameter    ——— 40 mm Diameter

Plummer Blocks

One Piece Housing Plummer Block

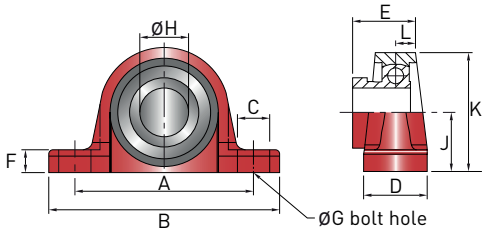

Model	A	B	C	D	E	F	G	H	J	K	L	Weight (kg)
PB1-20	96	127	20.5	32	34	14	10	20	33.33	65	10.5	0.6
PB1-30	121	152	23.5	40	39.2	17	12	30	42.9	82.5	12.5	1.1
PB1-40	136	175	24.5	48	47.7	19	12	40	49.2	99	15	1.9
PB1-50	159	203	26	54	49.7	22	16	50	57.2	115	17	2.8
PB1-60	186	240	29.5	60	60.5	26.5	16	60	69.9	138	21	4.5

Note

1. All dimensions in mm.
2. Bore diameter tolerances: (H6+H7)/2.
3. Material: Cast Iron housing with eccentric locking ring.
4. Dimensions are subject to change without notice.
5. For other styles and sizes of Plummer Blocks consult Power Jacks Ltd.

Split Housing Plummer Block

Plummer blocks are to DIN736 with anti-friction bearings with tapered bores and adapter sleeve. The housings are made of cast iron and are sealed with felt strips on both sides. The housings are designed to allow floating or located bearings (bearing position set with one or two locating rings). It is recommended when arranging drive systems only one plummer block with located bearing is used in one drive line, to avoid distortion of the drive.

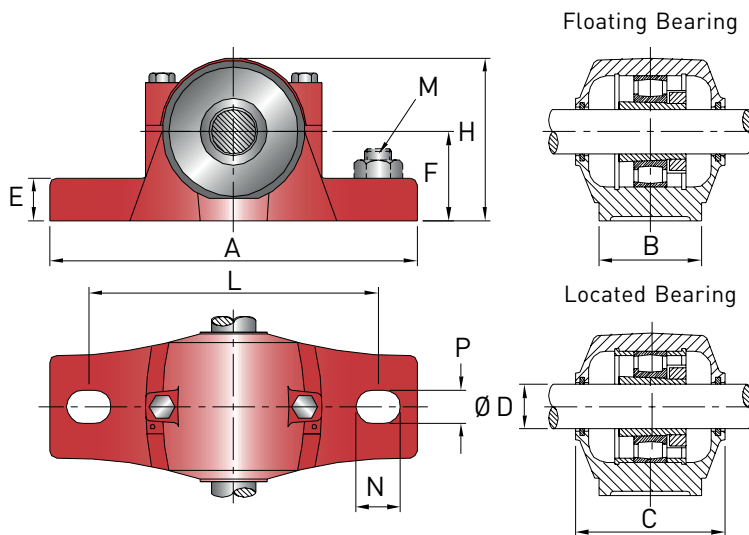

Model	ØD	A	B	C	E	F	H	L	M	N	P	Weight (kg)
PB-20	20	165	46	67	19	40	72	130	M12	20	15	1.4
PB-30	30	185	52	80	22	50	92	150	M12	20	15	2
PB-40	40	205	60	82	25	60	109	170	M12	20	15	2.9

Note

1. All dimensions in mm.
2. For other styles and sizes of Plummer Blocks consult Power Jacks Ltd.
3. Dimensions are subject to change without notice.

## Hand Wheels

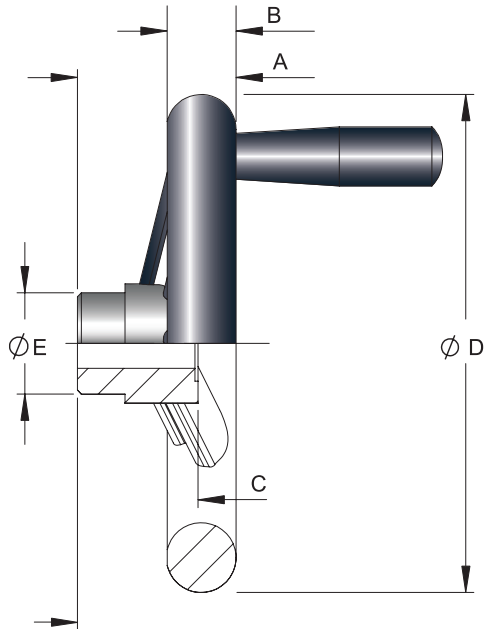

Model	A	B	C	D	E	H7 Bore
HW 005	40	14	36	98	24	Ø10
HW 010	50	22	38	157	32	Ø14
HW 025	56	24	43	198	40	Ø16
HW 050	56	24	43	198	40	Ø19
HW 100	66	30	44	247	49	Ø25
HW 200	78	32	56	288	58	Ø28
HW 300	108	40	77	375	58	Ø35
HW 500	108	40	77	375	58	Ø40

## Notes:

1. Material: Polished aluminium casting and rotating handle
2. Bored and keyed to BS4235 Part 1
3. All dimensions in millimetres unless otherwise stated
4. Other types of hand wheels are available on request. Consult Power Jacks.

# POWERJACKS

PRECISION ACTUATION

Power Jacks specialises in the design and manufacture of precision linear actuation, positioning and lifting equipment.

Our products are supplied globally across many sectors including Industrial Automation, Energy, Transport, Defence and Civil.

Power Jacks Ltd  
Kingshill Commercial Park  
Prospect Road, Westhill  
Aberdeenshire AB32 6FP  
Scotland (UK)  
Tel: +44 (0)1224 968968

[www.powerjacks.com](http://www.powerjacks.com)  
[sales@powerjacks.com](mailto:sales@powerjacks.com)

PJBSC-CD-EN-02

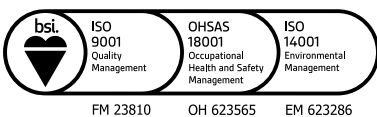

All information in this document is subject to change without notice. All rights reserved by Power Jacks Limited. May not be copied in whole or in part. ©Power Jacks Limited 2018, Aberdeenshire, Scotland, United Kingdom.

Follow Us  Facebook  LinkedIn  Twitter