

# POWERJACKS

PRECISION ACTUATION

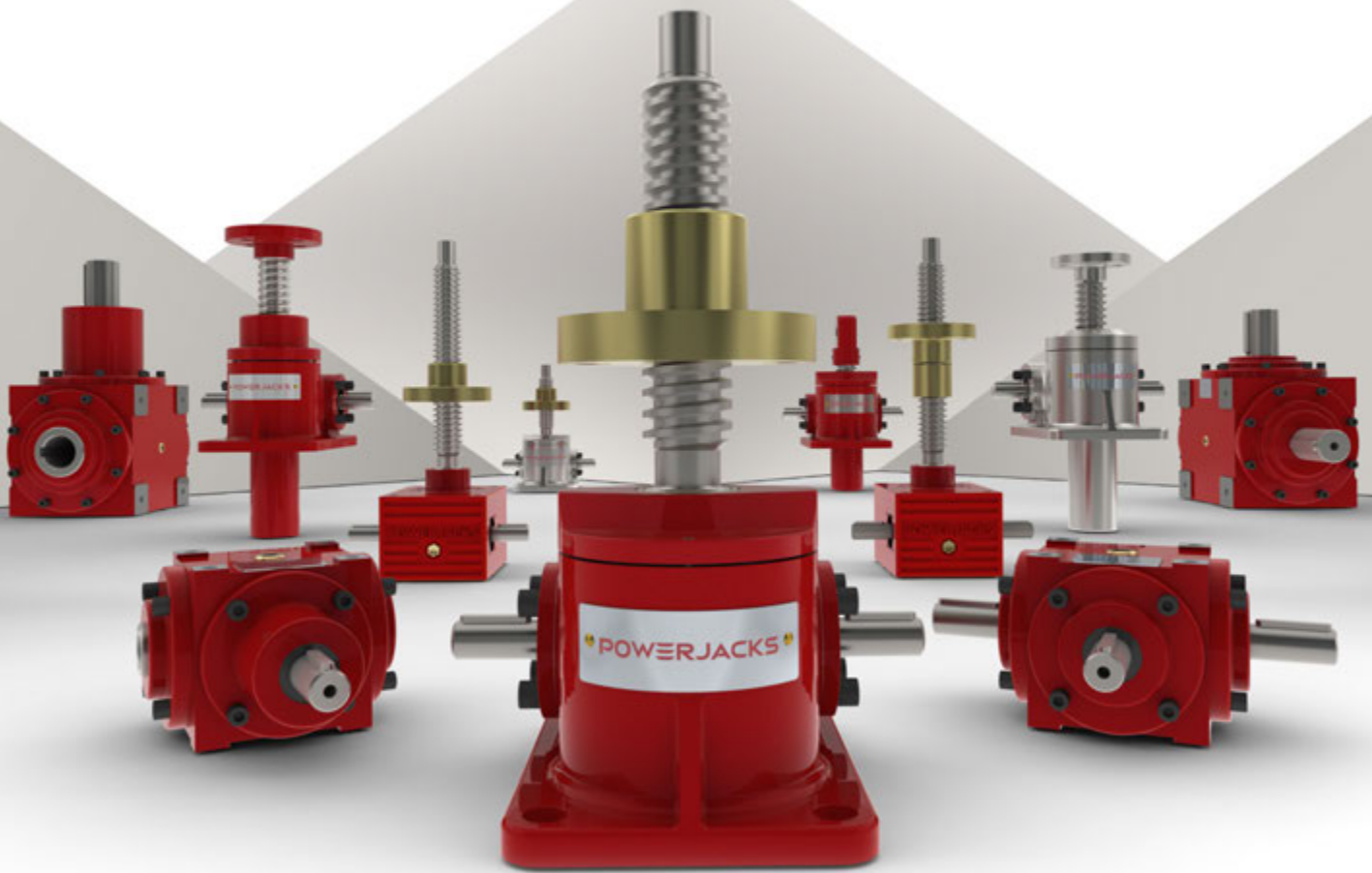

## SCREW JACK DESIGN GUIDE

**POWERJACKS**

Best engineered  
solution for precision  
linear actuation,  
power transmission  
& jacking systems.



# Capability



OUR EXPERTISE HAS BEEN BUILT ON A HISTORY OF MORE THAN 100 YEARS OF ENGINEERING, CRAFTSMANSHIP, VISIONARY DESIGN, QUALITY MANUFACTURE AND CUSTOMER CARE.



Power Jacks is a manufacturing/engineering company specialising in the design and manufacture of actuation, lifting and positioning solutions for applications in Industrial Automation, Energy, Defence, Medical, Transport, and the Civil Engineering sectors.

Headquartered near Aberdeen in the UK, the company is the UK's largest screw jack manufacturing facility, that uses the latest engineering technologies to deliver quality products (ISO 9001) that offer reliability, performance and economy.

Power Jacks deliver this high quality service in a safe (ISO 45001) and environmentally friendly (ISO 14001) working environment thanks to the highly trained, flexible and motivated teams that work throughout the business driving the company to higher levels of performance.

We know our customers demand our engineering expertise to help find a solution for their applications. We take pride in designing and delivering the best solution using standard or special designs that help improve your business.

Our Vision is to become the partner of choice for our products globally

Our Mission is to provide high quality lifting & positioning solutions.

# Global Reach

Power Jacks has local representation in 26 countries and supplies its products to more than 80 countries worldwide.



A global reach with a local service as we work closely with our customers to ensure the best solution for all their Electro-Mechanical solution applications.

- Headquarters & Factory
- Local Power Jacks Sales Offices
- Local Representative

**1. Introduction**

Compare Screw Jack Sizes.....	8
Translating Screw Jack Building System.....	10
Rotating Screw Jack Building System.....	11
Jacking Systems .....	12
Screw Jack Product Code.....	14
Selecting a Screw Jack.....	18

**2. C-Series - Machine Screw Jack ..... 22**

Features .....	23
Application Focus .....	26
Performance .....	27
C-Series Translating Machine Screw Jack 2.5kN .....	28
C-Series Rotating Machine Screw Jack 2.5kN .....	29
C-Series Translating Machine Screw Jack 5kN .....	30
C-Series Rotating Machine Screw Jack 5kN .....	31
C-Series Translating Machine Screw Jack 10kN .....	32
C-Series Rotating Machine Screw Jack 10kN .....	33
C-Series Translating Machine Screw Jack 25kN .....	34
C-Series Rotating Machine Screw Jack 25kN .....	35
C-Series Translating Machine Screw Jack 50kN .....	36
C-Series Rotating Machine Screw Jack 50kN .....	37
C-Series Translating Machine Screw Jack 100kN .....	38
C-Series Rotating Machine Screw Jack 100kN .....	39
Anti-Backlash .....	40
Anti-Rotation (Keyed).....	41
Safety Nuts.....	42
End Fittings for Translating Screw.....	43
Trunnion Mounts.....	44
Motor Adaptor .....	45
Limit Switches on Screw Jack Cover Pipe .....	46
Rotary Limit Switches for Screw Jacks.....	47

**3. E-Series - Machine Screw Jack ..... 48**

Features .....	49
Application Focus .....	52
Performance .....	54
E-Series Translating Machine Screw Jack 5kN .....	56
E-Series Rotating Machine Screw Jack 5kN .....	57
E-Series Translating Machine Screw Jack 10kN .....	58
E-Series Rotating Machine Screw Jack 10kN .....	59
E-Series Translating Machine Screw Jack 25kN .....	60
E-Series Rotating Machine Screw Jack 25kN .....	61
E-Series Translating Machine Screw Jack 50kN .....	62
E-Series Rotating Machine Screw Jack 50kN .....	63
E-Series Translating Machine Screw Jack 100kN .....	64
E-Series Rotating Machine Screw Jack 100kN .....	65
E-Series Translating Machine Screw Jack 200kN .....	66
E-Series Rotating Machine Screw Jack 200kN .....	67
E-Series Translating Machine Screw Jack 300kN .....	68
E-Series Rotating Machine Screw Jack 300kN .....	69
E-Series Translating Machine Screw Jack 500kN .....	70
E-Series Rotating Machine Screw Jack 500kN .....	71
E-Series Translating Machine Screw Jack 1000kN .....	72
E-Series Rotating Machine Screw Jack 1000kN .....	73

E-Series Translating Machine Screw Jack 1500kN .....	74
E-Series Rotating Machine Screw Jack 1500kN .....	75
E-Series Translating Machine Screw Jack 2000kN .....	76
E-Series Rotating Machine Screw Jack 2000kN .....	77
Variants .....	79
Anti-Backlash .....	80
Anti-Rotation (Keyed) .....	82
Anti-Backlash & Anti-Rotation (Keyed).....	84
Safety Nuts.....	86
Double Hub Nut for Rotating Screw Jacks.....	88
Double Clevis Screw Jacks .....	89

**4. E-Series - Stainless Steel Screw Jacks ..... 90**

Features .....	91
Application Focus .....	94
Performance .....	95
E-Series Translating Stainless Steel Screw Jack 10kN .....	96
E-Series Rotating Stainless Steel Screw Jack 10kN .....	97
E-Series Translating Stainless Steel Screw Jack 25kN .....	98
E-Series Rotating Stainless Steel Screw Jack 25kN .....	99
E-Series Translating Stainless Steel Screw Jack 50kN .....	100
E-Series Rotating Stainless Steel Screw Jack 50kN .....	101
E-Series Translating Stainless Steel Screw Jack 100kN .....	102
E-Series Rotating Stainless Steel Screw Jack 100kN .....	103
E-Series Translating Stainless Steel Screw Jack 200kN .....	104
E-Series Rotating Stainless Steel Screw Jack 200kN .....	105
E-Series Translating Stainless Steel Screw Jack 300kN .....	106
E-Series Rotating Stainless Steel Screw Jack 300kN .....	107
E-Series Translating Stainless Steel Screw Jack 500kN .....	108
E-Series Rotating Stainless Steel Screw Jack 500kN .....	109
E-Series Translating Stainless Steel Screw Jack 1000kN .....	110
E-Series Rotating Stainless Steel Screw Jacks 1000kN .....	111
Variants .....	113
Anti-Backlash .....	114
Anti-Rotation (Keyed) .....	116
Anti-Backlash & Anti-Rotation (Keyed) .....	118
Safety Nuts .....	120
Double Hub Nut for Rotating Screw Jacks.....	122
Double Clevis Screw Jack.....	123

**5. E-Series - Ball Screw Jack..... 124**

Features .....	125
Application Focus .....	128
Performance .....	129
E-Series Translating Ball Screw Jack 10kN .....	132
E-Series Rotating Ball Screw Jack 10kN .....	133
E-Series Translating Ball Screw Jack 25kN .....	134
E-Series Rotating Ball Screw Jack 25kN .....	135
E-Series Translating Ball Screw Jack 50kN .....	136
E-Series Rotating Ball Screw Jack 50kN .....	137
E-Series Translating Ball Screw Jack 100kN .....	138
E-Series Rotating Ball Screw Jack 100kN .....	139
E-Series Translating Ball Screw Jack 200kN .....	140



E-Series Rotating Ball Screw Jack 200kN .....	141
E-Series Translating Ball Screw Jack 300kN .....	142
E-Series Rotating Ball Screw Jack 300kN .....	143
Variants .....	145
Double Clevis Screw Jack .....	146
Anti-Rotation .....	147

#### 6. E-Series - Roller Screw Jack ..... 148

Features .....	149
----------------	-----

#### 7. E-Series - Screw Jack Accessories ..... 152

End Fittings .....	154
Machine Screw Jack Bellows Boots.....	156
Upright Machine Screw Jack Bellows Boots.....	157
Inverted Machine Screw Jack Bellows Boots .....	158
Ball Screw Jack Bellows Boots .....	159
Upright Ball Screw Jack Bellows Boots.....	160
Inverted Ball Screw Jack Bellows Boots.....	161
Stop Nuts & Hand Wheels .....	162
Trunnion Mounts.....	163
Motor Adapter.....	167
Limit Switches on Cover Pipe .....	168
Rotary Limit Switch - RLS .....	169

#### 8. Screw Jack Special Designs ..... 170

Custom Design Process.....	171
Special Design Examples .....	172
U-Series Subsea Screw Jacks.....	174
Application Focus.....	176

#### 9. Engineering Guide ..... 178

Screw Jack Performance.....	179
Machine Screw Jack Column Strength Charts .....	180
Ball Screw Jack Column Strength Charts.....	183

Critical Screw Speed Charts.....	185
Screw Jack Key Torque.....	186
Side Load Rating.....	187
Radial Loads on Screw Jack Worm Shaft.....	188
Axial Backlash Ratings.....	189
Lateral Movement Ratings .....	190
Operation .....	191
Calculations Formulae .....	197

# TRY OUR 3D CAD PORTAL

- 2D CAD Drawings
- 3D CAD Models
- Dimensioned Data Sheet

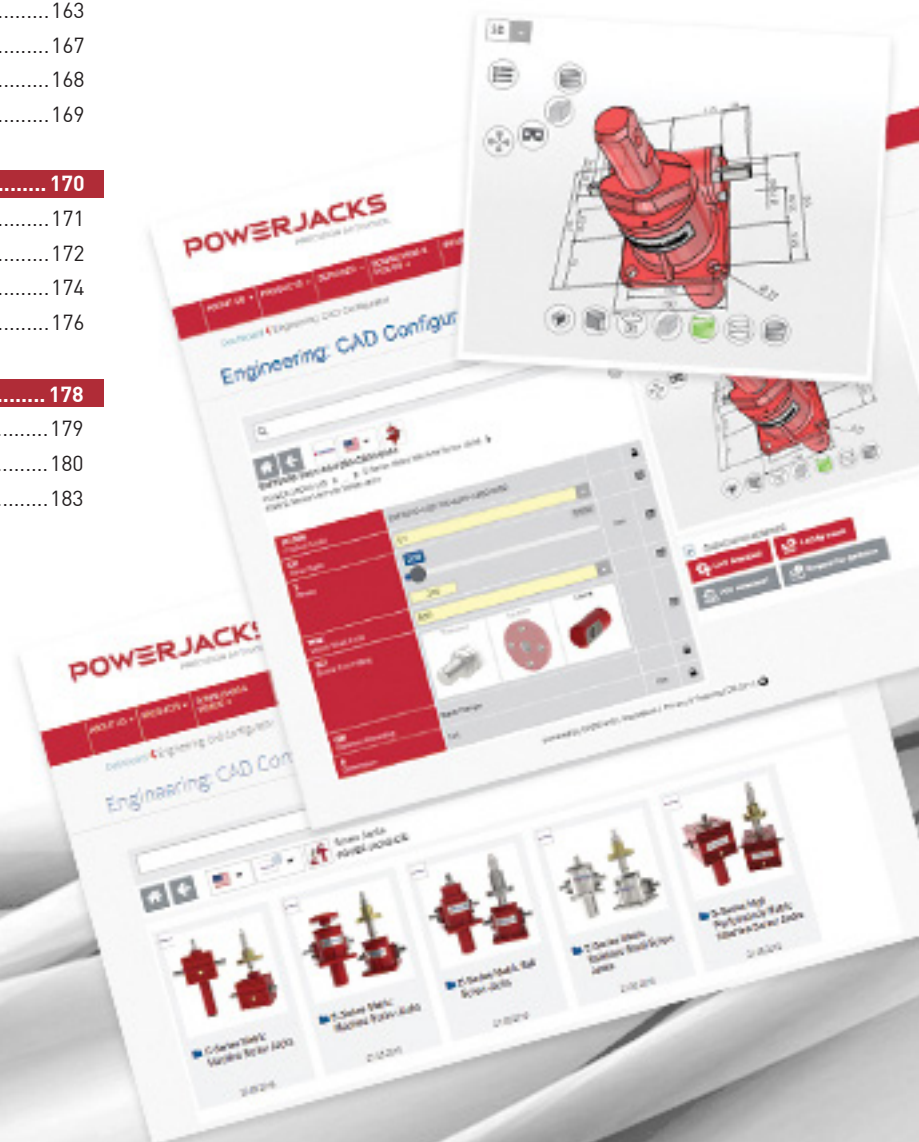

### 10. Bevel Gearbox Range-N

Features .....	201
Basic Range Overview .....	204
Product Code .....	205
How to Select a Bevel Gearbox .....	208
Performance .....	210
Torque and Power Rating .....	211
Load Factors .....	212
Permissible Shaft Loading .....	214
Shaft & Gear Configurations .....	215
Bevel Gearbox Range-N35 - Ratio 1:1 & 1.5:1 .....	216
Bevel Gearbox Range-N35 - Ratio 2:1 & above.....	218
Bevel Gearbox Range-N35 - Hollow Shaft - All Ratios .....	220
Bevel Gearbox Range-N37 - Ratio 1:1 & 1.5:1 .....	222
Bevel Gearbox Range-N37 - Ratio 2:1 & above.....	224
Bevel Gearbox Range-N37 - Hollow Shaft - All Ratios .....	226
Bevel Gearbox Range-N38 - Ratio 1:1 & 1.5:1 .....	228
Bevel Gearbox Range-N38 - Ratio 2:1 & above.....	230
Bevel Gearbox Range-N38 - Hollow Shaft - All Ratios .....	232
Bevel Gearbox Range-N39 - Ratio 1:1 & 1.5:1 .....	234
Bevel Gearbox Range-N39 - Ratio 2:1 & above.....	236
Bevel Gearbox Range-N39 - Hollow Shaft - All Ratios .....	238
Bevel Gearbox Range-N40 - Ratio 1:1 & 1.5:1 .....	240
Bevel Gearbox Range-N40 - Ratio 2:1 & above.....	242
Bevel Gearbox Range-N40 - Hollow Shaft - All Ratios .....	244
Bevel Gearbox Range-N42 - Ratio 1:1 & 1.5:1 .....	246
Bevel Gearbox Range-N42 - Ratio 2:1 & above.....	248
Bevel Gearbox Range-N42 - Hollow Shaft - All Ratios .....	250
Motors Adapters .....	252
Optional Features .....	253
Subsea Gearbox .....	254
Custom Applications.....	255

Safety Related Electro-Mechanical Contact Limit Switches...	298
Safety Related Contact Limit Switches Dimensions .....	299
Incremental Encoders .....	300
Absolute Encoders.....	301

### 12. Engineers Reference - Useful Information..... 303

Conversion Factors .....	304
Enclosure Ratings.....	306
Metric Nuts and Bolts.....	307
Metric Square and Rectangular Parallel Keys.....	308
Useful Formulae for Actuator Calculations .....	309
Limitation of Responsibility.....	310
Warranty.....	311

### 11. System Components..... 256

Reduction Gearboxes.....	257
Electric Motors.....	263
Couplings & Drive Shafts.....	277
Flexible Coupling .....	278
Jaw Type Flexible Coupling.....	279
Flexible Spacer Couplings (Self-Supporting Drive Shafts) .....	280
Steel Gear Couplings .....	281
Steel Gear Couplings - Continuous Sleeve .....	282
Steel Gear Couplings - Flanged Sleeve .....	283
Solid Drive Shafts.....	284
Plummer Blocks .....	286
Hand Wheels.....	287
Motion Control .....	289
RLS-51 Geared Cam Limit Switches .....	290
RLS-51 Features .....	291
RLS-51 Performance .....	292
RLS-51 Switching Contacts .....	293
RLS-51 Dimensions .....	292
Proximity Sensors.....	296
Compact Electro-Mechanical Contact Limit Switches.....	297

**Note:**

1. Designs subject to change without notice.
2. All colours for illustrative purposes only.

# NEED HELP SELECTING A GEARBOX? THEN TRY OUR PRODUCT SELECTOR

Just enter your application details and the Product Selector will recommend a suitable product with a calculation summary and links to the associated CAD and Data Sheets. An ideal tool if you are not familiar with the products or need answers fast.

**Engineering: Product Selector**

If you are not sure how to select a product then use our automated selection tool which combines the knowledge of our experienced engineers to...  
engineering assistant (AET) from anywhere in the world.

Overview

Enter details below to find a product that meets your requirements.

**Enter Application Data**

**Get Recommended Product with**

- CAD
- Data Sheets

Product Details

Port Number	30	30
Input Speed (rpm)	1500	1500
Output Speed (rpm)	750	750
Input Torque (Nm)	85	85.7
Output Torque (Nm)	170	171.4
Input Power (kW)	0.127	0.127
Output Power (kW)	0.254	0.254
Shaft Type	Solid Shaft	Solid Shaft
Configuration	3-Way	3-Way
Shaft Ratio	2:1	2:1

Download PDF Exam Sheet  
Download 2D/3D CAD Files  
Add to Shopping Cart

[www.powerjacks.com/portal](http://www.powerjacks.com/portal)

### C-Series - Translating Screw

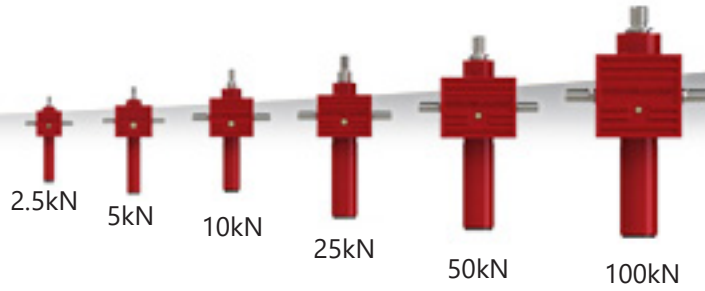

### E-Series - Translating Screw

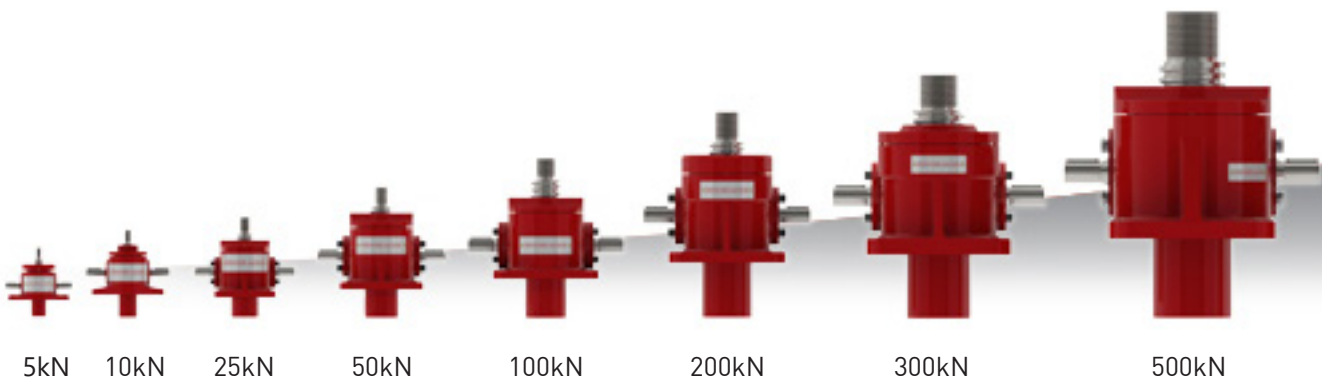

### E-Series - Rotating Screw

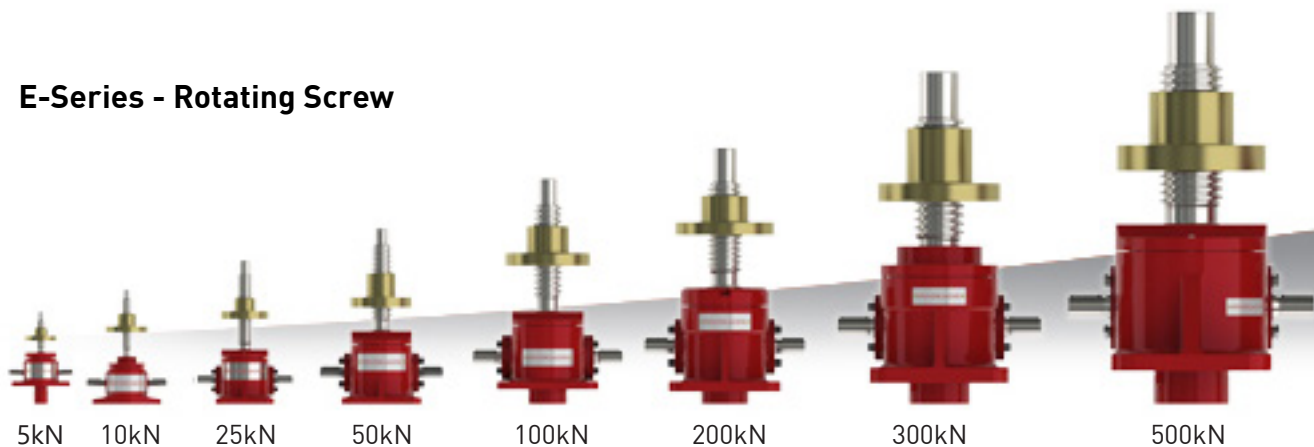

### C-Series - Rotating Screw

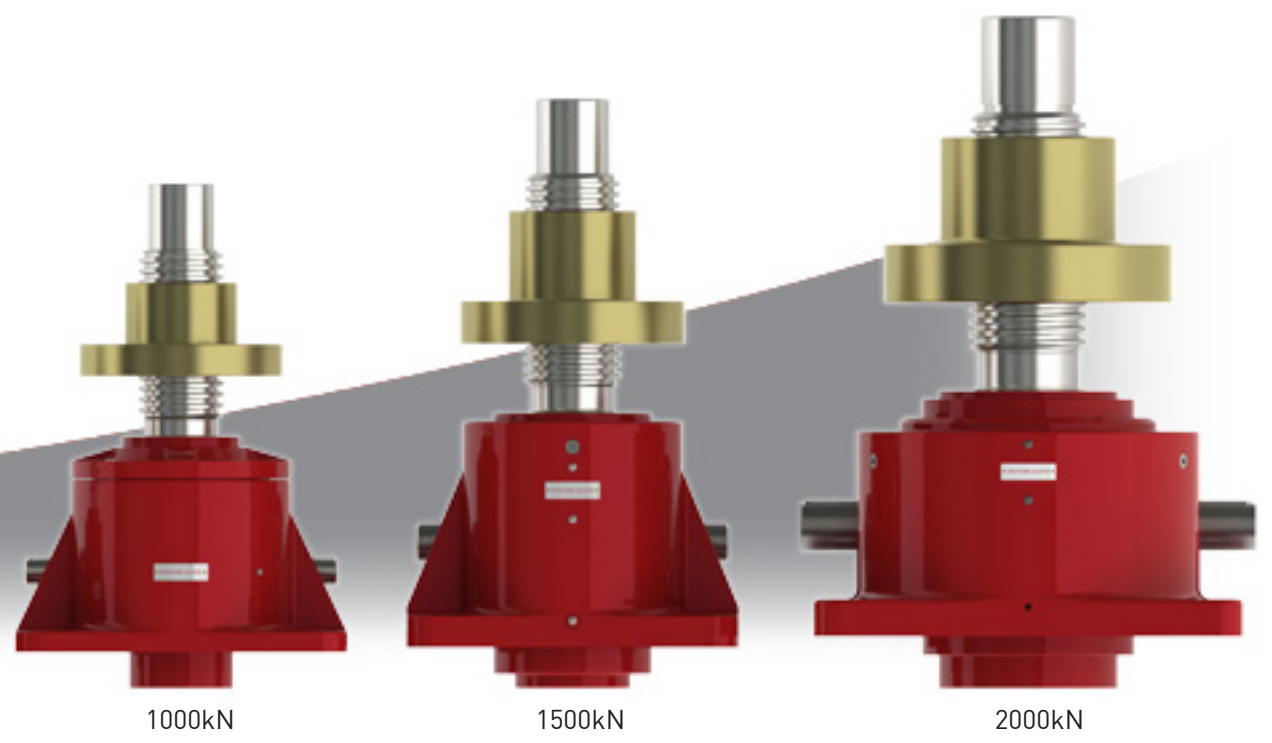
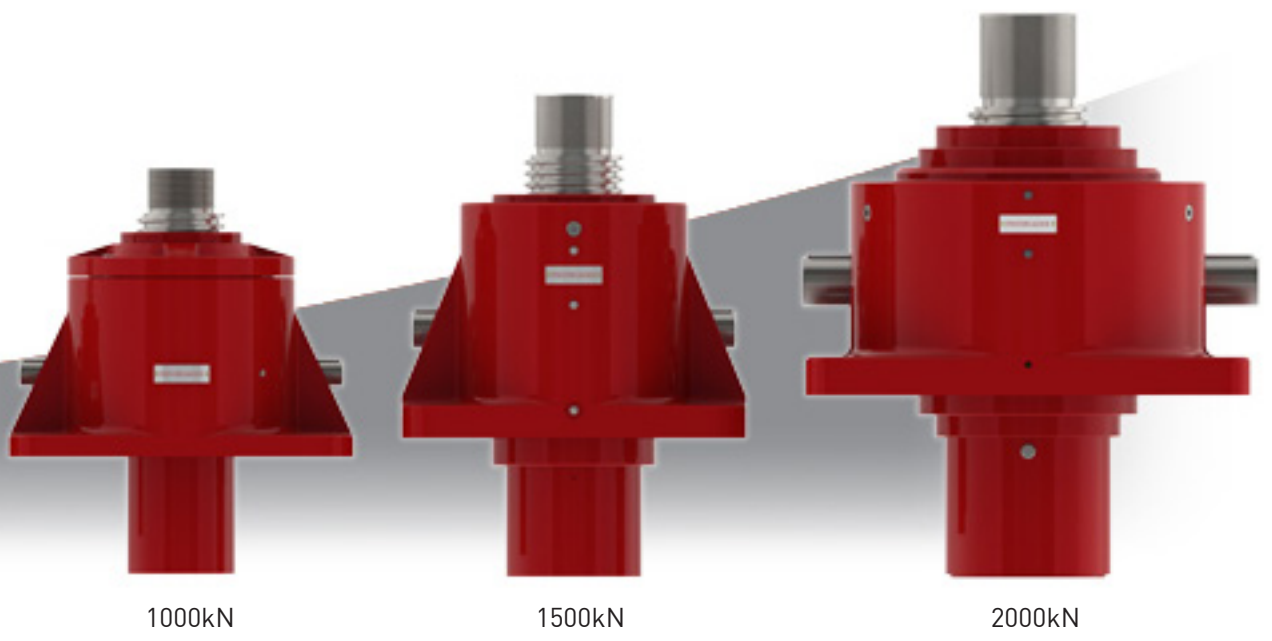
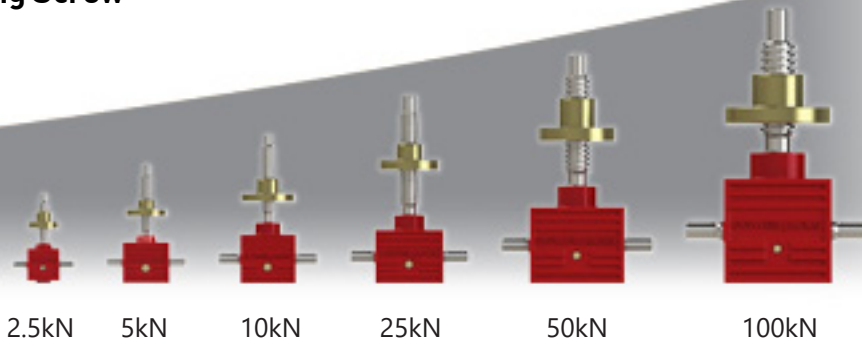



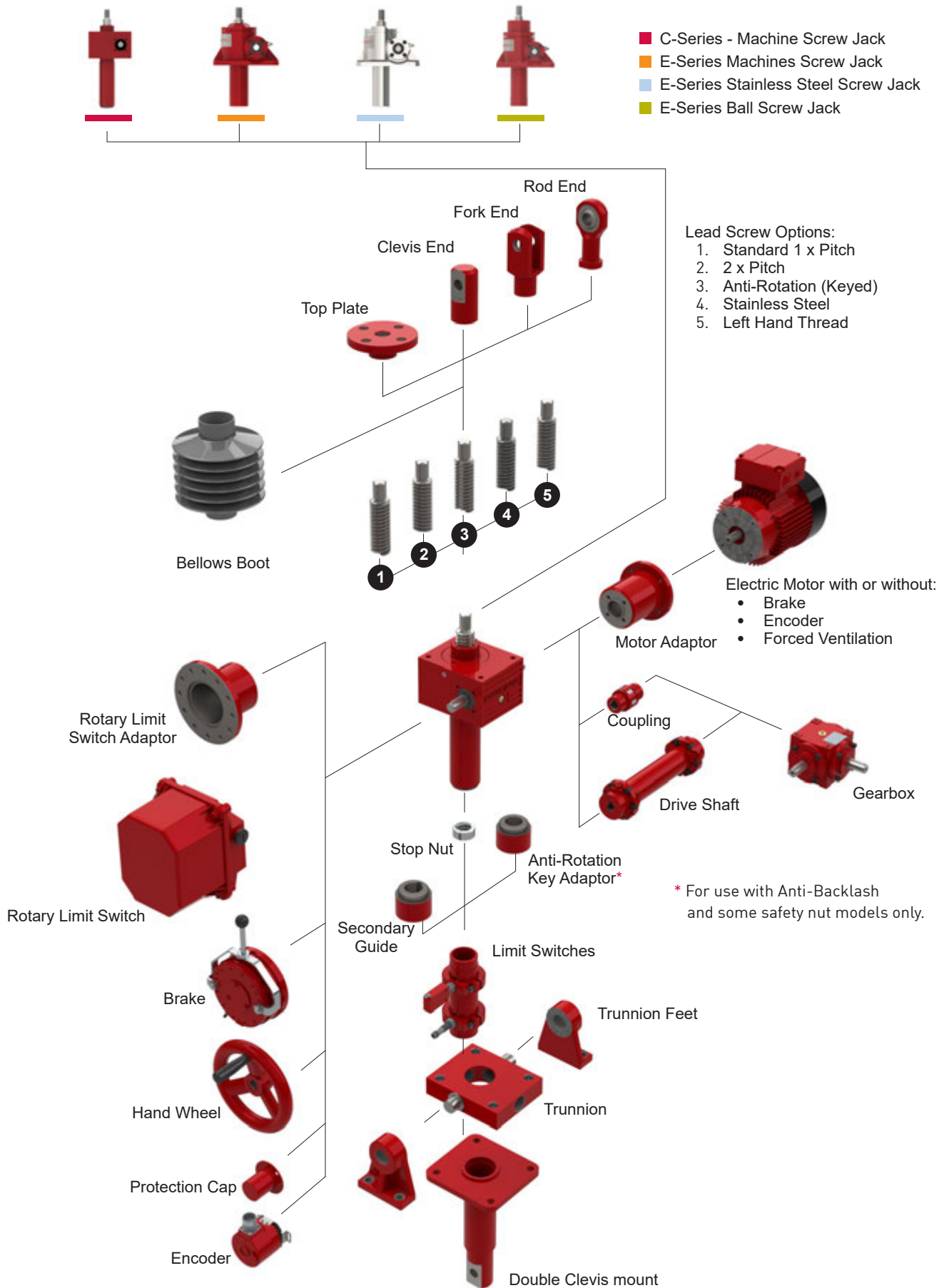

■ Special Screw Jacks Design Available when you need more than the standard solution.

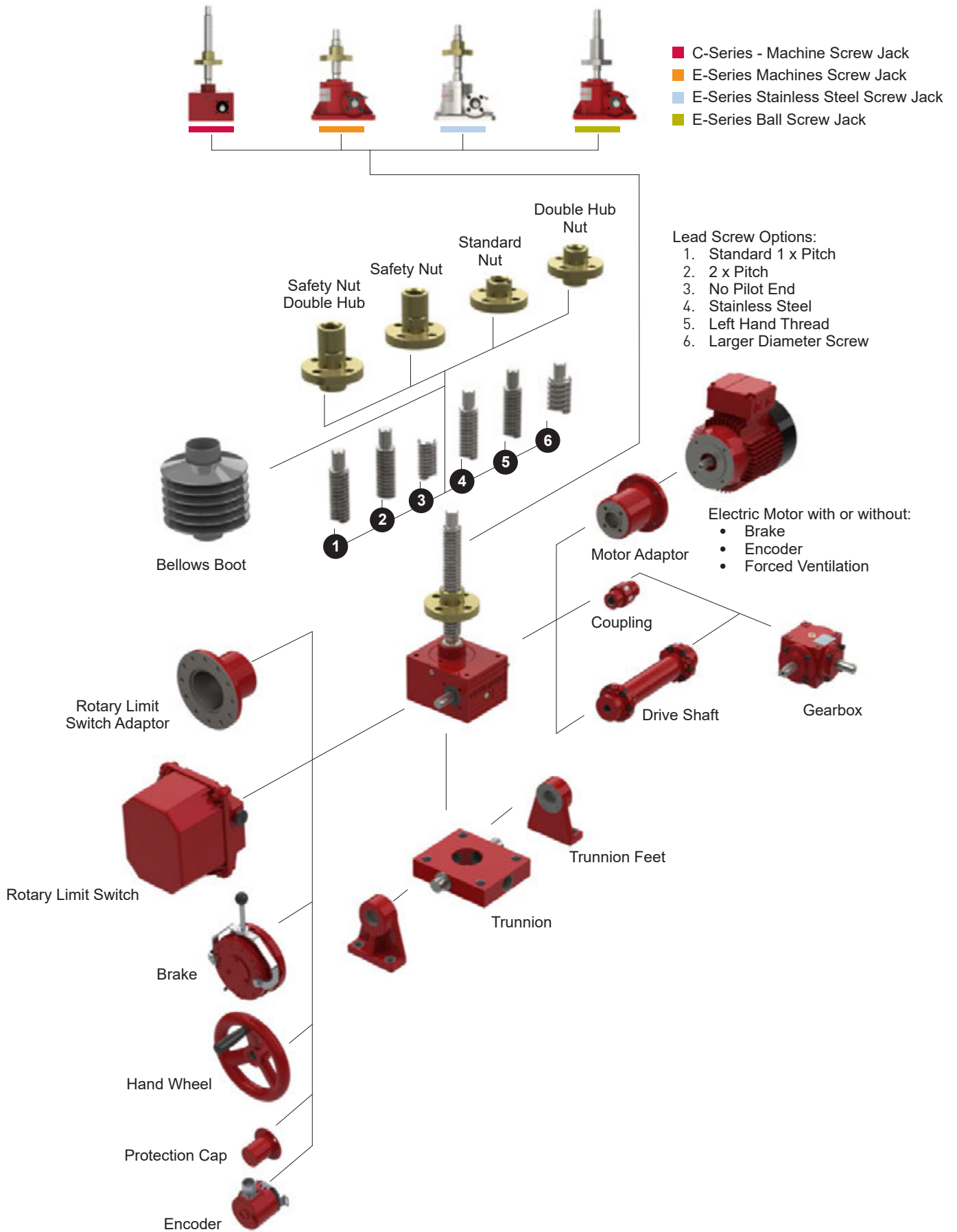

■ Special Screw Jacks Design Available when you need more than the standard solution.



Screw jacks can be connected together in systems so that multiple units can be operated and controlled together. These jacking system arrangements or configurations can be built in many formats with the use of bevel gearboxes, motors, reduction gearboxes, drive shafts, couplings, plummer blocks and motion control devices.

Four of the most popular system configurations are the 'H', 'U', 'T' and 'I' configured jacking systems. Note that multiple screw jacks can be linked together mechanically or electrically. The latter is useful if there is no space for linking drive shafts.

### Typical 'H' configuration System

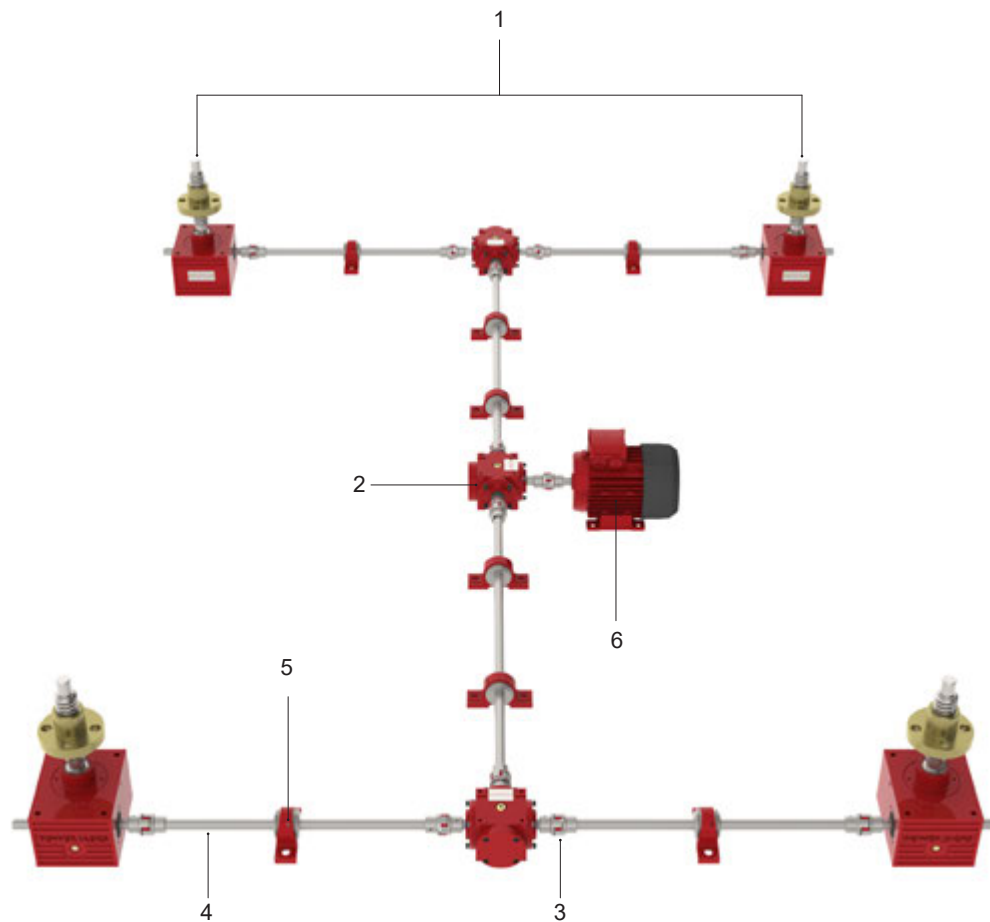

1. Screw Jack  
C-Series Rotating Machine Screw Jack shown here.
2. Bevel Gearbox  
Range-N Spiral Bevel Gearboxes
3. Flexible Coupling  
A range of couplings are available to suit each systems requirements including Jaw, Spacer and Geared types.
4. Drive Shaft  
Every drive shaft is manufactured to order for each system design. Self supporting drive shafts (spacer couplings) are also available.
5. Shaft Supports (plummer blocks).
6. Electric Motor  
Standard electric motors in 3 phase, 1 phase, DC and servo designs. Supplied as a basic motor or as part of a geared motor. Brakes are available for all motors.

Jacking systems are not limited to the number of screw jacks shown here. They are regularly supplied to clients with 2, 4, 6, 8 jack systems. Larger systems can extend up to 16 or higher. With the use of electronic synchronisation/control multiple systems or screw jacks can be used in unison. Extending the possible number of screw jacks used in unison in excess of 100.

To facilitate electronic control of screw jacks, feedback devices (eg encoder, limit switch) are available, mounted on the screw jack or its motor or another system component.

#### 'U' Configuration System



#### 'I' Configuration System



#### 'T' Configuration System



1 GROUP-1 - Screw Jack Gearbox Definition

2 GROUP-2 - Screw Jack Features

3 GROUP-3 - Accessories

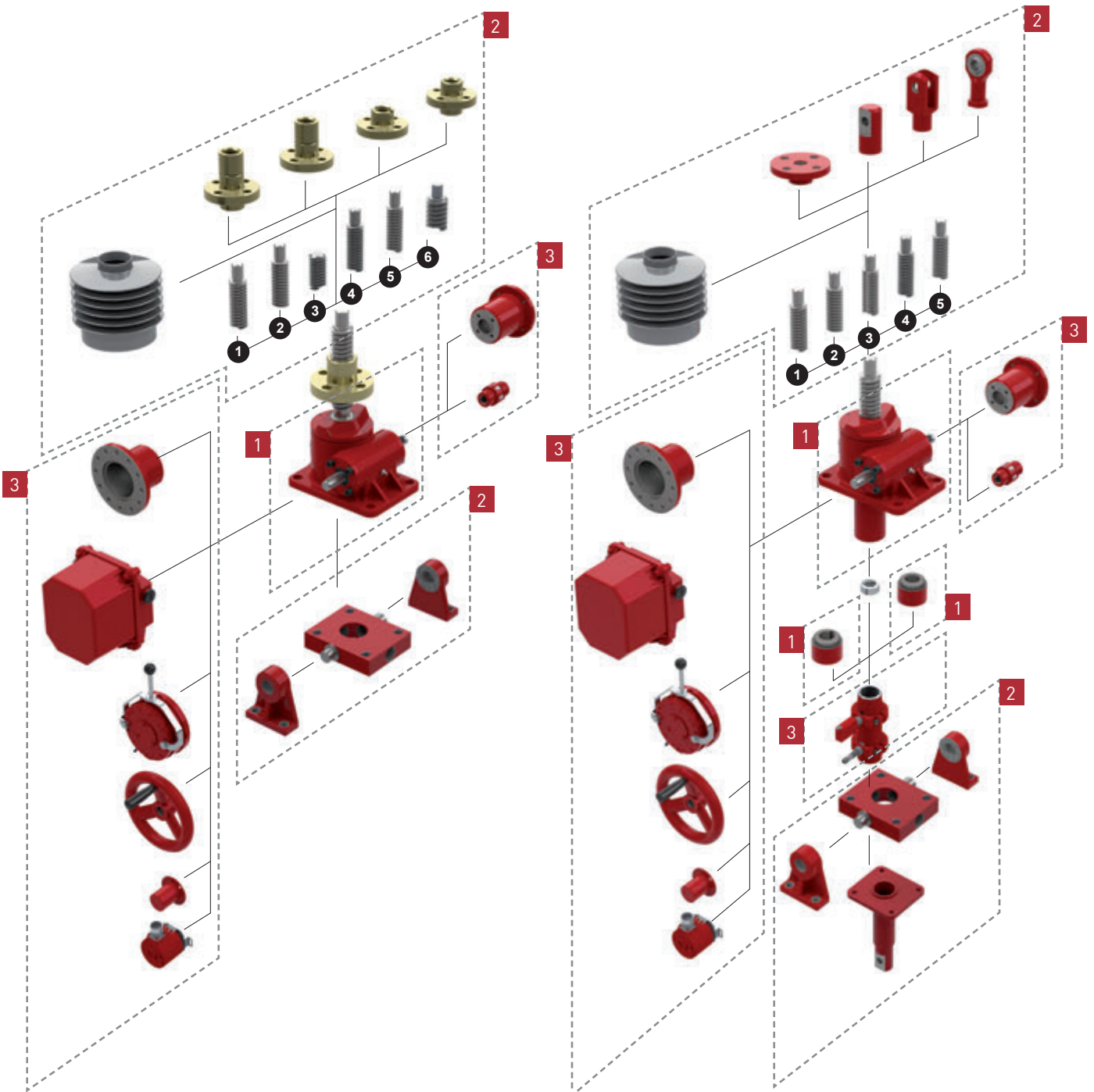

**1 GROUP-1 - Screw Jack Gearbox Definition****1-Screw Jack Series**

E	Series
C	Series

**2 - Screw Type**

M	Machine Screw
B	Ball Screw

**3- Screw Configuration**

R	Rotating Screw
T	Translating Screw

4-7 - Capacity	0002	0005	0010	0025	0050	0100	0200	0300	0500	1000	1500	2000
kN	2.5	5	10	25	50	100	200	300	500	1000	1500	2000

**8 - Character Space****9-Gearbox Type**

U	Upright
I	Inverted
V	Upright - All Stainless Steel Screw Jack #16
J	Inverted - All Stainless Steel Screw Jack #16
C	Cubic

**12 - Gear Ratio**

1	Option 1 Ratio
2	Option 2 Ratio
A	Option 1 Ratio with gear rotation monitor #12
B	Option 2 Ratio with gear rotation monitor #12

**10 - Gearbox Feature - 1**

0	None
K	Anti-Rotation (Keyed)
C	Secondary Guide
E	Anti-Rotation (keyed) with Secondary Guide
H	Double Hub Nut #1, #12
T	Trunnion Nut
U	Trunnion Nut with Feet

**13 - Lifting Screw Lead**

1	Option 1 Lead - Right Hand (Standard) #4
2	Option 2 Lead - Right Hand #4
A	Option 1 Lead - Left Hand #5
B	Option 2 Lead - Left Hand #5

**14 - Worm Shaft Type #16**

0	Standard Material
N	Nickel Plated Worm Shaft
S	Stainless Steel Worm Shaft

**11 - Gearbox Feature - 2**

0	None
A	Anti-Backlash (this option is zero backlash for ball screws)
B	Anti-Backlash with wear monitor - Visual
C	Anti-Backlash with wear monitor - Sensor
R	Safety Nut Tension
S	Safety Nut Compression
T	Safety Nut Tension with Wear Monitor - visual
U	Safety Nut Compression with wear monitor - visual
V	Safety Nut Tension with Wear Monitor - Sensor
W	Safety Nut Compression with wear monitor - Sensor

**15 - Worm Shaft Ends**

0	Both
L	Left Hand Only
R	Right Hand Only
X	Both with Protective Cap on LHS #11
Y	Both with Protective Cap on RHS #11

**16 - Character Space**

### 2 GROUP-2 - Screw Jack Features

17-20 - Stroke	0000
Stroke in mm	0-9999

21 - Character Space
----------------------

22 - End Type #16 #17	
E	Threaded End
C	Clevis End
T	Top Plate
F	Fork End (standard available up to 200KN)
R	Rod End (standard available up to 200KN)
J	Plain End
P	Pilot End #1
N	No Pilot End #1

23 - Gearbox Mounting	
B	Base Mount
C	Second Clevis on Cover Pipe Standard #6 #9
E	Second Clevis on Cover Pipe 90 degree #9
T	Trunnion Mount Standard #2
U	T + Trunnion Feet
X	Trunnion Mount 90 degree #3
Y	X + Trunnion Feet

24 - Lifting Screw Material #16	
0	Standard
S	Stainless Steel
M	Standard with Low Friction Coating (Molycote)
A	Standard with Protective Coating (Armaloy)

25 - Lifting Screw Covers	
0	Cover Pipe & No Bellows Boot #15
B	Cover Pipe & Fabric Bellows Boot #9
F	Fabric Bellows Boot x 2 - Rotating Screw
R	Cover Pipe & Rubber Bellows Boot #9
S	Rubber Bellows Boot x 2 - Rotating Screw
N	No Cover Pipe & No Bellows Boot #9
W	Cover Pipe & PU Waterproof Bellows Boot #9
X	PU Waterproof Bellows Boot x2 - Rotating Screw

26 - Character Space
----------------------

### 3 GROUP-3 - Accessories

27 - Drive Type			
0	None, Standard Features (tapped holes on gearbox side if present)	H	Hand Wheel - LHS
A	Motor Adapter Only, B14 - LHS	J	Hand Wheel - RHS
B	Motor Adapter Only, B14 - RHS	R	Rotation Indicator (Visual) on worm shaft - LHS
C	Motor Adapter B14 & Coupling - LHS	T	Rotation Indicator (Visual) on worm shaft - RHS
E	Motor Adapter B14 & Coupling - RHS		

28- Motor Frame Size / Drive Interface Size			
0	Not Applicable	F	112 Size IEC Frame
A	63 Size IEC Frame	G	132 Size IEC Frame
B	71 Size IEC Frame	H	160 Size IEC Frame
C	80 Size IEC Frame	I	180 Size IEC Frame
D	90 Size IEC Frame	J	200 Size IEC Frame
E	100 Size IEC Frame		

29 - Mounting Kit for Limit Switches & Stop Nuts #18			
0	None	P	Inductive Proximity Sensor, 2, End of Stroke, Adjustable #9
C	RLS-51 Rotary Cam Limit Switch - RHS	S	SKA Rotary Cam Limit Switch - RHS
D	RLS-51 Rotary Cam Limit Switch - LHS	T	SKA Rotary Cam Limit Switch - LHS
E	RLS-51 Rotary Cam Limit Switch - RHS with Stop Nut	U	SKA Rotary Cam Limit Switch - RHS with Stop Nut
F	RLS-51 Rotary Cam Limit Switch - LHS with Stop Nut	V	SKA Rotary Cam Limit Switch - LHS with Stop Nut
M	Electro-Mechanical Limit Switch, 2, End of Stroke, Adjustable #9	W	Stop Nut

30 - Paint, Lubricant, Seals #13 #14	
0	Standard Paint, Lubricant & Seals
1	Standard Paint & Food Grade Lubricant & Standard Seals
2	Standard Paint, Nuclear Grade Lubricant & Seals
3	Standard Paint, High Temperature Lubricant & Seals
4	Standard Paint, Low Temperature Lubricant & Seals
5	Standard Paint, Biodegradable Lubricant & Standard Seals
A	No Paint, Standard Lubricant & Seals
B	No Paint & Food Grade Lubricant & Standard Seals
C	No Paint, Nuclear Grade Lubricant & Seals
D	No Paint, High Temperature Lubricant & Seals
E	No Paint, Low Temperature Lubricant & Seals
F	No Paint, Biodegradable Lubricant & Standard Seals
G	Standard Primer, Lubricant & Seals
H	Standard Primer & Food Grade Lubricant & Standard Seals
I	Standard Primer, Nuclear Grade Lubricant & Seals
J	Standard Primer, High Temperature Lubricant & Seals
K	Standard Primer, Low Temperature Lubricant & Seals
L	Standard Primer, Biodegradable Lubricant & Standard Seals
M	Epoxy Paint, Standard Lubricant & Seals
N	Epoxy Paint & Food Grade Lubricant & Standard Seals
P	Epoxy Paint, Nuclear Grade Lubricant & Seals
R	Epoxy Paint, High Temperature Lubricant & Seals
S	Epoxy Paint, Low Temperature Lubricant & Seals
T	Epoxy Paint, Biodegradable Lubricant & Standard Seals

Notes:

- #1 Rotating screw models only.
- #2 Trunnions on same side as worm shaft (standard).
- #3 Trunnions at 90° to worm shaft.
- #4 Standard right hand thread form. Worm shaft turns clockwise to extend screw.
- #5 Left hand thread form. Worm shaft turns anti-clockwise to extend screw.
- #6 Standard is clevis axis parallel to worm shaft.
- #7 Limit switch mounting included.
- #8 Plain End "A" has same dimensions as "E - threaded end" except no thread form.
- #9 Translating screw models only.
- #10 Basic Translating and Rotating units in both Upright and Rotating versions (all variant & accessories on application).
- #11 All models except E-Series 5 kN & 10 kN models
- #12 Models 10 - 100kN only
- #13 Power Jacks defined standard paint - available as a data sheet.
- #14 Power Jacks defined standard lubricant.
- #15 For Rotating Screw Jacks the "Cover Pipe" may actually be a "Plug"
- #16 All Stainless Steel Screw Jack by default defines the worm shaft, lifting screw and end fitting as Power Jacks standard stainless steel material.
- #17 If Lifting Screw is Stainless Steel material then the End Fitting is Stainless Steel as well by default.
- #18 Limit Switches not included. Limit switch specification to be detailed as separate item.

Product Code Example

**CMT0050-C0A1100-0810-CT00-0000** C-Series, Machine Screw, Translating, 50kN, Cubic, Anti-Backlash mechanism, 6:1 gear ratio, 9mm lead on screw, 810mm Stroke, Clevis End, Trunnion Mount, standard drive features, standard paint and lubrication.

1	2	3	4	5	6	7	8	9	10	11	12	13	14	15	16	17	18	19	20	21	22	23	24	25	26	27	28	29	30
C	M	T	0	0	5	0	-	C	0	A	1	1	0	0	-	0	8	1	0	-	C	T	0	0	-	0	0	0	0

**EMT0100-U001100-0790-TB00-0000** E-Series, Machine Screw, Translating, 100kN, Upright, No extra gearbox features, 8:1 gear ratio, 12mm lead on screw, 790mm Stroke, Top Plate, Base Mount, standard drive features, standard paint and lubrication.

1	2	3	4	5	6	7	8	9	10	11	12	13	14	15	16	17	18	19	20	21	22	23	24	25	26	27	28	29	30
E	M	T	0	1	0	0	-	U	0	0	1	1	0	0	-	0	7	9	0	-	T	B	0	0	-	0	0	0	0

**EMT0200-V002100-1250-CB00-0000** E-Series, Machine Screw, Translating, 200kN, Upright, Stainless Steel Screw Jack, No extra gearbox features, 8:1 gear ratio, 12mm lead on screw, 1250mm Stroke, Clevis End, Base Mount, standard drive features, standard paint and lubrication.

1	2	3	4	5	6	7	8	9	10	11	12	13	14	15	16	17	18	19	20	21	22	23	24	25	26	27	28	29	30
E	M	T	0	2	0	0	-	V	0	0	2	1	0	0	-	1	2	5	0	-	C	B	0	0	-	0	0	0	0

**EBR0025-I001200-0500-FB0B-CAE0** E-Series, Ball Screw, Rotating, 25kN, Inverted, No extra gearbox features, 6:1 gear ratio, 10mm lead on screw, 500mm Stroke, Fork End, Base Mount, Bellows Boot screw protection, Motor Adapter & Coupling Kit for IEC 63 Frame size on Left Hand Side (LHS), RLS-51 rotary cam limit switch on Right Hand Side (RHS) with Stop Nut, standard paint and lubrication.

1	2	3	4	5	6	7	8	9	10	11	12	13	14	15	16	17	18	19	20	21	22	23	24	25	26	27	28	29	30
E	B	R	0	0	2	5	-	I	0	0	1	2	0	0	-	0	5	0	0	-	F	B	0	B	-	C	A	E	0

## Five Step Guide to Initial Screw Jack Selection

The following selection procedure is applicable for Machine Screw and Ball Screw Jacks.

### Calculate Power and Torque Requirements

Select a screw jack from the tables with adequate load carrying capacity and note the screw jack static and dynamic efficiency for required input speed.

#### Step 1 - Screw Jack Input Speed

$$N \text{ (rpm)} = \frac{\text{Linear Speed (mm/min)} \times \text{Gear Ratio}}{\text{Pitch (mm)} \times N^\circ \text{ of Starts on Lifting Screw}}$$

Input speed should not exceed 1800 rpm.  
Number of starts on lifting screw is usually 1, unless otherwise stated.

**Note:** Screw Lead = Pitch x No of Starts

#### Step 2 - Operating Input Power (kW), $P_{in}$

$$P_{in} \text{ (kW)} = \frac{\text{Load (kN)} \times \text{Linear Speed (mm/min)}}{60000 \times \eta_d}$$

$\eta_d$  = Dynamic Screw Jack Efficiency

#### Step 3 - Operating Input Torque

$$T_{ino} \text{ (Nm)} = \frac{P_{in} \text{ (kW)} \times 9550}{N \text{ (rpm)}}$$

#### Step 4 - Screw Jack Start-Up Torque

$$T_{ins} = \frac{\text{Load (kN)} \times \text{Pitch (mm)} \times N^\circ \text{ of Starts on Lifting Screw}}{2 \times \pi \times \eta_s \times \text{Gear Ratio}}$$

$\eta_s$  = Static Screw Jack Efficiency

**Note:** Screw Lead = Pitch x No of Starts

#### Step 5 - Mechanical Power and Torque Check

Check whether the screw jack power and torque required for the application is not greater than the maximum allowable mechanical input power ( $P_{mechanical}$ ) and Start-Up Torque at Full Load ( $T_s$ ) values specified in the screw jack performance tables.

If  $P_{mechanical} > P_{in}$  &  $T_s > T_{ins}$  then the screw jack selected is acceptable for power requirements.



## Example Selection

### Application Constraints

- Load on Screw Jack = 15 kN in Tension
- Linear Speed required = 100 mm/min

Consider all application constraints then choose a screw jack that looks suitable for the application with a load rating equal to or greater than the maximum working load. For this example, a 25 kN E-Series Machine Screw Jack (refer P60) with translating screw, 6:1 gear ratio, single start lifting screw (6 mm lead).

### Calculate Power and Torque Requirements

#### Step 1 - Screw Jack Input Speed

$$N \text{ (rpm)} = \frac{100 \text{ (mm/min)} \times 6 \text{ (Gear Ratio)}}{6 \text{ (mm)} \times 1 \text{ (N}^\circ \text{ of starts on Lifting Screw)}}$$

$$N = 100 \text{ rpm}$$

Input speed should not exceed 1800 rpm.

#### Step 2 - Operating Input Power (kW), $P_{in}$

$$P_{in} \text{ (kW)} = \frac{15 \text{ (kN)} \times 100 \text{ (mm/min)}}{60000 \times 0.264}$$

$$\eta_d = 0.264 \text{ (Refer P60)}$$

$$P_{in} = 0.095 \text{ kW}$$

#### Step 3 - Operating Input Torque

$$T_{ino} \text{ (Nm)} = \frac{0.095 \text{ (kW)} \times 9550}{100 \text{ (rpm)}}$$

$$T_{ino} = 9.1 \text{ Nm}$$

#### Step 4 - Screw Jack Start-Up Torque

$$T_{ins} = \frac{15 \text{ (kN)} \times 6 \text{ (mm)} \times 1 \text{ (N}^\circ \text{ of starts on Lifting Screw)}}{2 \times \pi \times 0.201 \times 6 \text{ (Gear Ratio)}}$$

$$T_{ins} = 11.9 \text{ Nm}$$

$$\eta_s = 0.201 \text{ (refer P60)}$$

#### Step 5 - Mechanical Power and Torque Check

Find the screw jacks mechanical power and torque rating from the performance data tables (refer P60).

$$P_{\text{mechanical}} = 1.5 \text{ kW} > P_{in} \text{ and } T_s = 19 \text{ Nm} > T_{ins}$$

Therefore the screw jack selected is suitable for application for initial constraints tested, further analysis may be required to ensure the screw jack is suitable for all application conditions. Continue with further selection calculations or consult Power Jacks Ltd.

## Screw Jack Constraints for Detailed Selection

### Lifting Screw Column Strength

For compressive loads on the screw jack lifting screw column strength calculations are required to check for buckling. As a screw jack selection guide use the following process:

1. Determine the maximum column strength (L) for the screw jack being considered.
2. Referring to the relevant column buckling chart determine the permissible compressive load (Wp) corresponding to the column length (L) for the appropriate end constraints. This permissible compressive load is the maximum load (inclusive of shock loads) which may be applied to the screw jack for a given column length.
3. Where an application involves human cargo or there is a risk to personnel, it is highly recommended that the permissible compressive load (as calculated above) be factored by 0.7 to enhance working safety. (Equivalent to a column strength safety factor of 5).

$$W_{phc} = W_p \times 0.7 \quad \text{(Permissible compressive load for personnel risk applications)}$$

- Note**
1. For detailed analysis of screw jacks and their systems consult Power Jacks.
  2. Safety factor of 3.5 for column strength's used for normal industrial cargo.

### Lifting Screw Critical Speed

For fast operating rotating screw jacks, the critical speed (rotational speed) of the lifting screw needs to be considered in case of shaft whirling. To calculate the critical speed for rotating screw jacks:

1. Refer to the appropriate critical speed chart.
2. Select the correction factor  $F_{cs}$  corresponding to the end support conditions for the application.
3. From the critical speed chart, select the critical speed corresponding to the unsupported screw length (m) and the screw jack load rating (kN).
4. Calculate the limiting critical speed with the formula: **Limiting Critical Speed = Critical screw speed x  $F_{cs}$**

### Lifting Screw Deflection

The lifting screw of a screw jack mounted horizontally will deflect under its own weight to some extent. The amount of deflection tolerable ( $y_T$ ) should be less than 0.5 mm per metre.

#### Deflection Factors, $F_{sd}$

Fixed/Fixed.  $F_{sd} = 8$

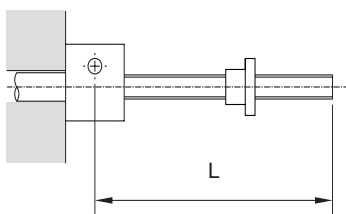

Fixed/Fixed.  $F_{sd} = 186$

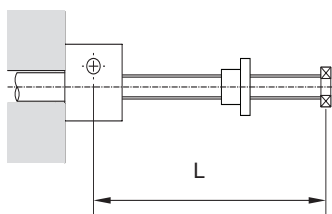

Fixed/Fixed.  $F_{sd} = 384$

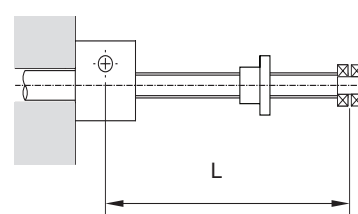

$$\text{Deflection, } y, \text{ (mm)} = \frac{6 \times 10^{-9} \times L^4}{F_{sd} (d-p)^2}$$

$$\text{Deflection Tolerable, } y_T, \text{ (mm)} = \frac{0.5 \times L}{1000}$$

L = Lifting Screw Length (mm)  
 d = Diameter of Lifting Screw (mm)  
 p = Pitch of Lifting Screw (mm)

If  $y < y_T$  then the lifting screw deflection is acceptable.

**Note:** This is only a deflection guide. For detailed analysis, including methods to reduce deflections, consult Power Jacks Ltd.

**Screw Jack Input Torque**

Start up/static torque values are listed in all performance tables. Whereas dynamic torque values are either calculated using the tabulated dynamic efficiencies or taken direct from torque tables where listed. For detailed screw jack analysis consult Power Jacks Ltd.

**Side Loads on Screw Jacks**

It is recommended that all side loads ( $F_{sl}$ ) are carried by guides in your arrangement and not by the lifting screw and nut. If there are any side loads on the screw jack, they must not exceed those tabulated in the Engineering Guide, Side Load Rating Section, and it must be noted that any such loads will adversely affect the life of the lifting screw and nut.

**Radial Forces on Screw Jack Worm Shaft**

For applications where a screw jack is belt driven, radial force ( $F_R$ ) values exerted on the worm shaft must not exceed those tabulated in the Engineering Guide Section. Values are tabulated for the metric machine screw jacks and ball screw jacks. The values are maximum values for the screw jacks at rated load regardless of worm speed or load direction.

**Screw Jack Self-Locking**

Approximately 50% of machine screw jacks are self-locking either in the gearbox or the lifting screw, however to ensure there is no self-lowering and to reduce drift due to the motor slowing, a brake is recommended. Standard motor frame size brakes will be suitable for most applications with only slight vibration and thermal fluctuation present. Motor selection as normal.

For dynamic braking consult Power Jacks.

Ball screw jacks and roller screw jacks always require a brake as their high efficiency makes them self-lowering.

Use the closest standard brake size that is greater or equal to the motor brake torque required.

- Note**
1. Self lowering can occur in any jacking system not fitted with a brake, where high levels of vibration are present in the application.
  2. Power Jacks recommend the use of a brake on single screw jack applications in the vertical position.

**Jacking System Power Input**

Total Input Power for Jacking Systems (kW),  $P_s$ :

$$P_s = \frac{\text{Input Power per Screw Jack (kW)} \times \text{Number of Screw jacks}}{\text{Arrangement Efficiency} \times \text{Gearbox Efficiency}}$$

Number of Screw Jacks in System	2	3	4	6-8
Jacking System Efficiency	0.95	0.90	0.85	0.80

**Gearbox Efficiency** = Bevel Gearbox Efficiency x Reduction Gearbox Efficiency

**Bevel Gearbox Efficiency** = 0.95 typical

**Reduction Gearbox Efficiency** = Consult unit details, if no reduction gearbox present assume efficiency of 1.

**Note**

For Screw Jacks connected in-line, the worm shaft can transmit up to 3 times the torque for a single screw jack at its maximum capacity, except the E--0200 (200kN) Unit which can transmit 1.5 times the torque.

## C-Series - Machine Screw Jack

MODULAR CONTEMPORARY  
CUBIC DESIGN WITH BOLT-  
ON ACCESSORIES TO TAILOR  
SCREW JACK FOR YOUR  
EXACT APPLICATION NEEDS.

**TRANSLATING SCREW JACKS**

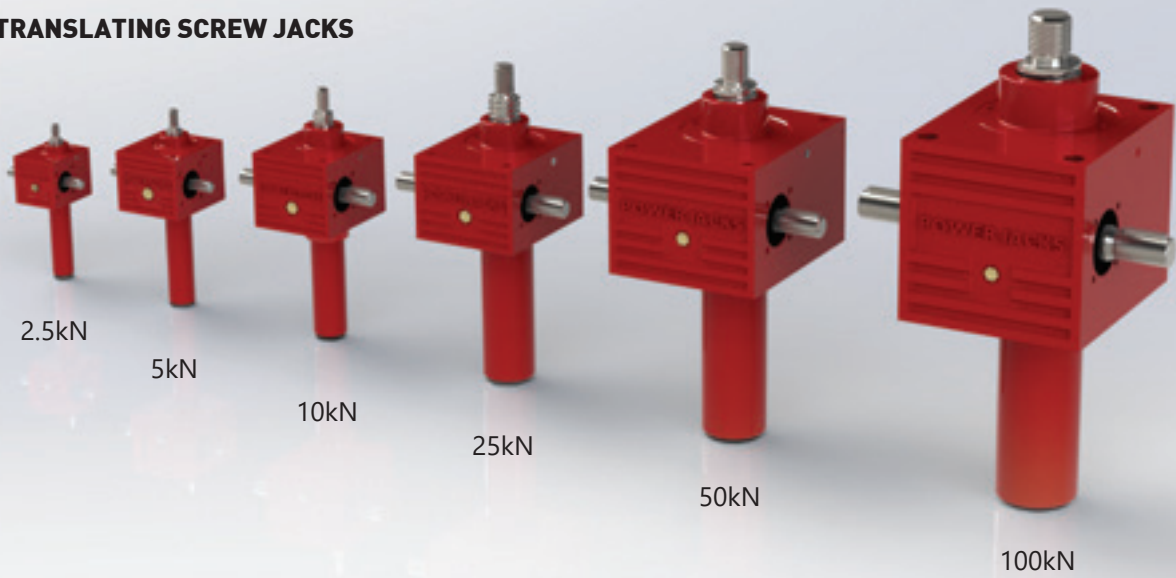

**Key Features**

- Metric Cubic Machine Screw Jacks
- Capacities - 2.5kN to 100kN as standard
- Translating and Rotating Screw
- Precision Worm Gear Set
- Standard Performance Power Jack
- 2 Gear ratios and 2 screw lead as standard
- Anti-backlash and anti-rotation (keyed) options
- 6 mounting options including trunnion and double clevis
- Special custom designs available

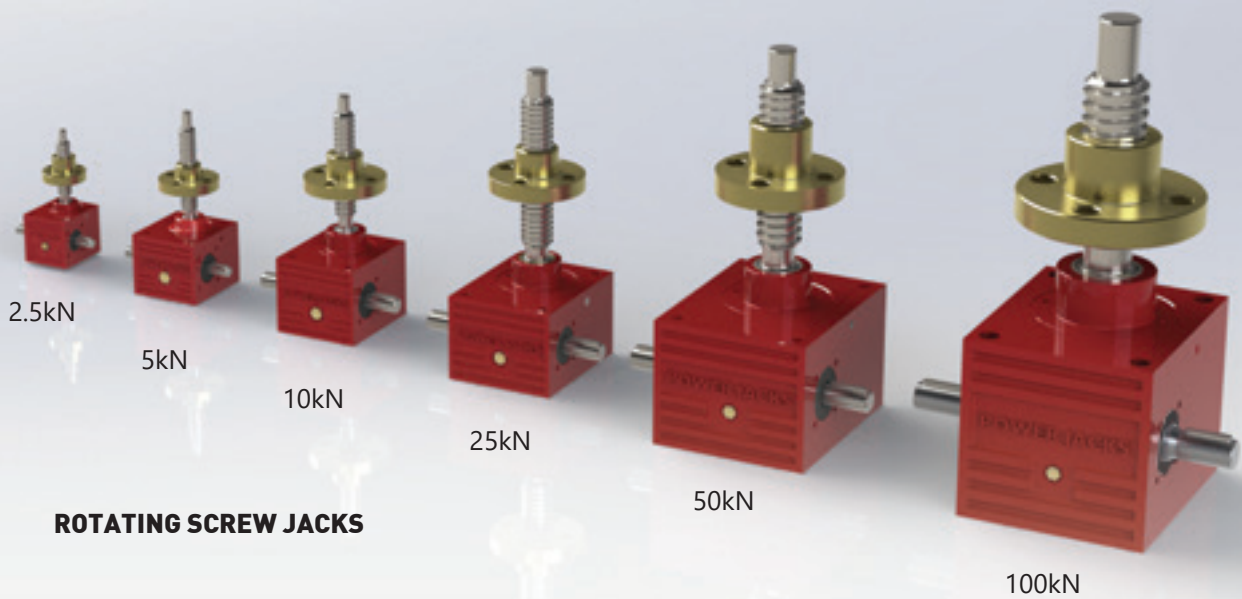

**ROTATING SCREW JACKS**

# 2 C-Series - Machine Screw Jack

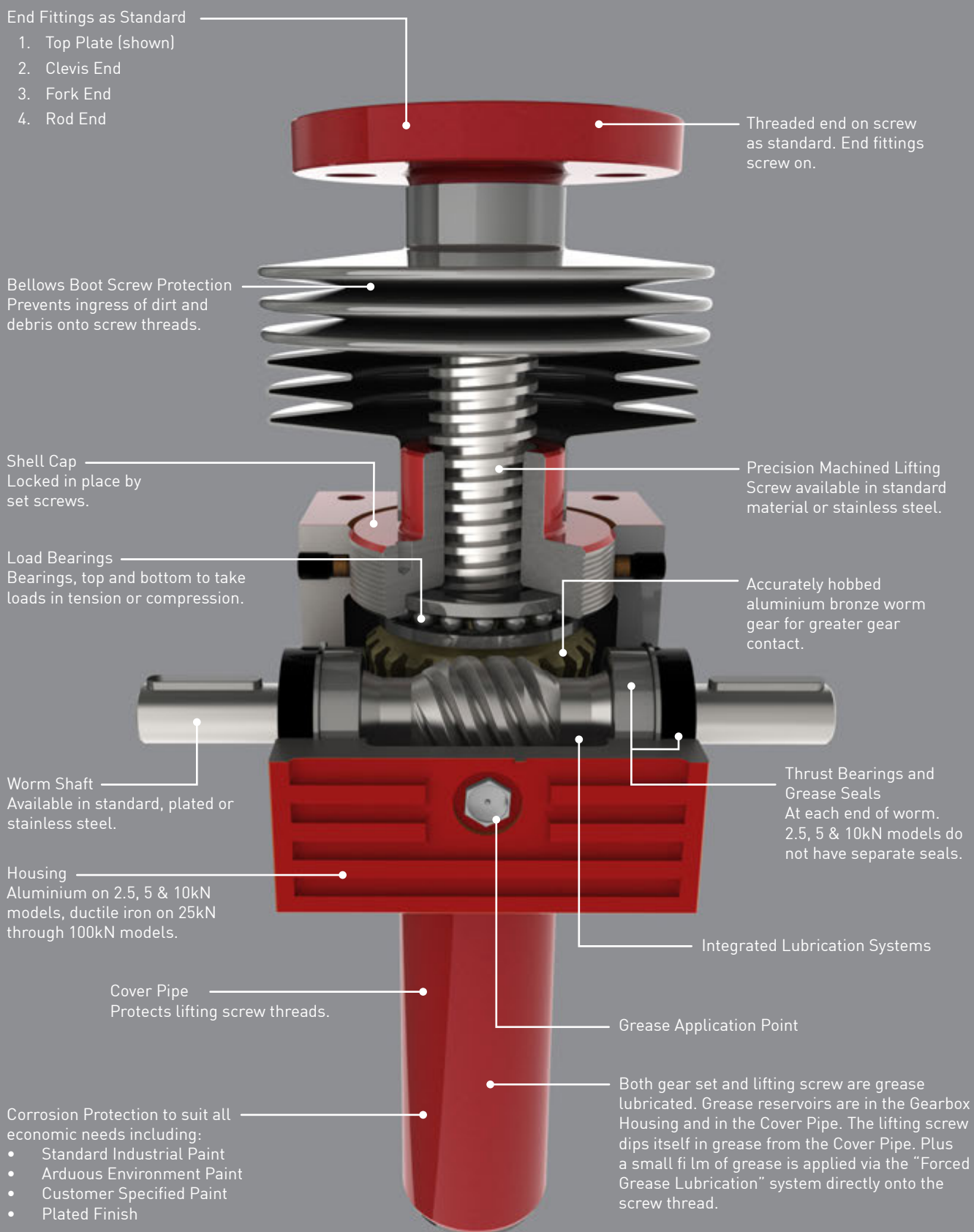

This is where the worm shaft pushes grease through small radial holes in the gear directly onto the screw thread ensuring optimum lubrication.

Translating Screw



Rotating Screw



Typical Applications

Conventional Machine Screw Jacks are most widely used for intermittent duty cycles, as the screw jack incorporates a precision worm gear set in a rugged casting delivering positive, precise actuation. Available in a comprehensive range of materials and fittings with the option for special designs for specific application requirements. Used in a wide variety of industry sectors including metal processing, automotive, energy, civil and aerospace.

Standard Designs

The standard C-Series screw jack is available in translating and rotating screw designs in capacity sizes from 2.5kN to 100kN. It's design is compact and versatile with a large selection of standard options and accessories so you can configure a standard design that is just right for your application. These variants include Anti-Backlash, Anti-Rotation (Keyed) and Safety Nut designs.

Special Designs

We can fully customise our screw jacks so that your application can be the best.

Customisation can be anything from a small modification such as an extra bolt hole on an end fitting to a completely new design of screw jack based on our class leading technology.

For more details please see the Special Screw Jack information in Section-8 or contact us today with your requirements. Our team are looking forward to working with you.

Selecting the Right Screw Jack

Consider all application constraints then choose a product that looks suitable for the intended application. Calculate the power and torque requirements. This is a 5 step process:

- Screw Jack Input Speed (RPM)
- Operating Input Power (kW)
- Operating Input Torque (Nm)
- Screw Jack Start-up Torque (Nm)
- Mechanical Power and Torque Check

Systems

The screw jacks can be connected together in systems so that multiple units can be operated and controlled together. These jacking system arrangements or configurations can be built in many formats with the use of bevel gearboxes, motors, reduction gearbox, drive shafts, couplings, plummer blocks and motion control devices.

The use of bevel gearboxes allows the distribution of drive throughout a jacking system. The gearboxes come in 2,3 and 4 way drive types. See Bevel Gearbox Section-10 for more details.

Bevel gearboxes and other system components can also be supplied in stainless steel or other corrosion resistant designs.



Two of the most popular system configurations are the 'H' and 'U' configured jacking systems. Remember that multiple screw jacks can be linked together mechanically or electrically. The latter is useful if there is no space for linking drive shafts.

If multiple machine screw jacks are connected in a mechanically linked system then the complete system may be considered self-locking. If you would like this checked consult Power Jacks. Alternatively, to be sure, include a brake on the system either as a stand alone device or as a brake motor.





## SPECIAL EFFECT CAR REVEAL SYSTEM

C-Series Screw Jack System was pivotal to a dramatic 'magic mirror' effect that slowly unveiled the car to impressed onlookers during the UK launch.

The car sat inside a ring of pillars of coloured LED light, and was covered by a mirrored box that had a horizontal split. To make the car appear and disappear, the sides of the mirrored box were moved up and down in synchronisation so the top and bottom halves of the car were revealed at the same time. To keep the mirror operation simple yet effective, a four screw jack system in an H-configuration using 50kN C-Series rotating machine screw jacks was used. To move the mirrors in different directions at the same time using 1 lifting screw per screw jack required a customised design.

A special lifting screw which had right hand and left hand threads on the same screw was built into each of the screw jacks. The screw length matched the height of the installation: the upper half had a right hand thread form and the lower half had a left hand thread form.

A lifting nut with corresponding thread ran on each thread form portion of the screw, so each screw had two lifting nuts. In total the system had eight lifting nuts (two per screw jack) – four connected to the top mirror section and four to the bottom mirror section. As the jacking system was operated, the nuts ran in opposing directions so the mirror sections did likewise at the same speed in a mechanically synchronised manner.

By using a mechanically linked system, the whole operation was controlled by one motor which greatly simplified the control system and minimised costs.

The four C-Series cubic machine screw jacks selected for the system were mechanically linked to the electric motor via three bevel gearboxes from the ultra compact Range-N design.

For more application examples see the 'Power at Work' brochure or [www.powerjacks.com](http://www.powerjacks.com).



Screw Jack Model <sup>4</sup>	CM-0002		CM-0005		CM-0010		CM-0025		CM-0050		CM-0100			
Capacity	kN		2.5		5		10		25		50		100	
Lead Screw <sup>1</sup>	Diameter (mm)		14		16		20		30		40		55	
	Lead	Option	1	2	1	2	1	2	1	2	1	2	1	2
		mm	3	6	3	6	5	10	6	12	9	18	12	24
Gear Ratios	Option 1		5:1		5:1		5:1		6:1		6:1		8:1	
	Option 2		20:1		20:1		20:1		24:1		24:1		24:1	
Turn of worm for travel of lead screw	Option 1	1 Turn	0.6mm	1.2mm	0.6mm	1.2mm	1mm	2mm	1mm	2mm	1.5mm	3mm	1.5mm	3mm
	Option 2	4 Turn	0.15mm	0.3mm	0.15mm	0.3mm	1mm	2mm	1mm	2mm	1.5mm	3mm	2mm	4mm
Maximum Input Power (kW)	Option 1		0.750		0.250		0.375		1.5		3		3.75	
	Option 2		0.075		0.120		0.19		0.375		0.55		1.125	
Start up torque at full load (Nm) <sup>2</sup>	Option 1		1.2	1.6	2.5	3.3	6.8	9.4	19.8	26.4	56.0	76.0	115.9	156.6
	Option 2		0.6	0.8	1.1	1.4	3.0	4.1	8.7	11.7	25.5	34.7	60.5	81.9
Maximum Through Torque (Nm) <sup>7</sup>	Option 1		3.6		7.5		20.4		59.4		168.0		347.7	
	Option 2		1.8		3.3		9.0		26.1		76.5		181.5	
Static Efficiency <sup>3</sup>	Option 1		0.203	0.300	0.189	0.291	0.236	0.339	0.201	0.302	0.213	0.314	0.206	0.305
	Option 2		0.107	0.159	0.102	0.165	0.133	0.192	0.113	0.171	0.117	0.172	0.132	0.195
Dynamic Efficiency <sup>3</sup>	Option 1		0.268	0.383	0.252	0.37	0.306	0.424	0.264	0.383	0.281	0.398	0.272	0.388
	Option 2		0.159	0.228	0.160	0.234	0.194	0.268	0.167	0.242	0.172	0.244	0.190	0.271
Lead Screw Restraining Torque (Nm) <sup>5</sup>	-		3.6	4.9	8.0	10.5	22	30	76	102	210	290	575	780
Worm Shaft Radial Load (N) <sup>6</sup>			75		150		325		380		740		1000	
Maximum Input Speed (rpm)	-		1800		1800		1800		1800		1800		1800	
Gear Case Material			Aluminium		Aluminium		Aluminium		SG Iron		SG Iron		SG Iron	
Weight (kg) – stroke = 150mm	Translating		0.77		1.7		3.0		8.3		19.5		19.5	
	Rotating		0.85		1.9		3.1		8.7		20.2		20.2	
Weight (kg) – per extra 25mm	Translating		0.027		0.085		0.11		0.21		0.32		0.32	
	Rotating		0.023		0.035		0.05		0.11		0.19		0.19	

**Notes:**

1. All metric machine screws have a trapezoidal thread form.
2. For loads of 25% to 100% of screw jack capacity, torque requirements are approximately proportional to the load.
3. Efficiency values for standard grease lubricated worm gear box and lifting screw.
4. All C-Series screw jacks have grease lubricated gearbox and lead screw as standard.
5. Torque required to prevent the lead screw or lead nut from rotating if no anti-rotation device fitted.
6. Radial force applied midway along worm shaft key at 90° to key.
7. Maximum transmittable torque through worm shaft, not through gear set.

## Performance

Screw Jack Model	CM-0002	
Capacity	kN	2.5
Lead Screw	Diameter (mm)	14
	Lead (mm)	3   6
Gear Ratios	Option 1	5:1
	Option 2	20:1
Turn of worm for travel of lead screw	Option 1   1 Turn	0.6mm   1.2mm
	Option 2   4 Turn	0.15mm   0.3mm
Maximum Input Power (kW)	Option 1	0.750
	Option 2	0.075
Start up torque at full load (Nm)	Option 1	1.2   1.6
	Option 2	0.6   0.8
Maximum Through Torque (Nm)	Option 1	3.6
	Option 2	1.8
Static Efficiency	Option 1	0.203   0.300
	Option 2	0.107   0.159
Dynamic Efficiency	Option 1	0.268   0.383
	Option 2	0.159   0.228
Lead Screw Restraining Torque (Nm)	-	3.6   4.9
Worm Shaft Radial Load (N)		75
Maximum Input Speed (rpm)	-	1800
Gear Case Material		Aluminium
Weight (kg) - stroke = 150mm	Translating	0.77
	Rotating	0.85
Weight (kg) - per extra 25mm	Translating	0.027
	Rotating	0.023

## CMT0002 Closed Heights

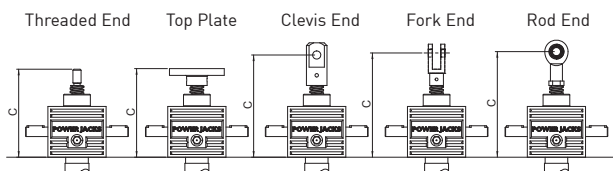

Closed Height 'C'	Threaded End	Top Plate	Clevis End	Fork End	Rod End
CMT0002	77	92	77	98	94
Stroke (mm)	With Bellows Boots (B)				
0 - 250	104	118	104	124	120
251 - 500	134	148	134	154	150
501 - 800	132	153	132	155	152
1501 - 2000	290	290	310	313	315

## CMT0002 Stop Nut



Stop nut provides a full power mechanical stop at the end of the lead screw. To be used as a safety feature in emergency conditions.  
SN = Stroke + 25mm

**Note:**

1. All dimension in millimetres unless otherwise stated.
2. Designs subject to change without notice.

## CMT0002-C00

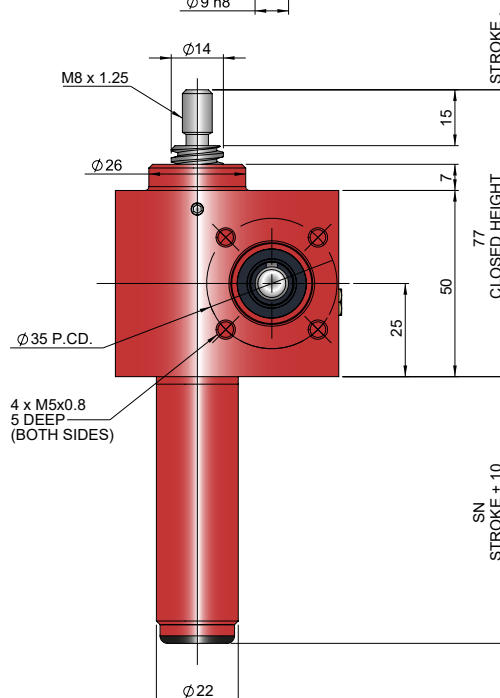
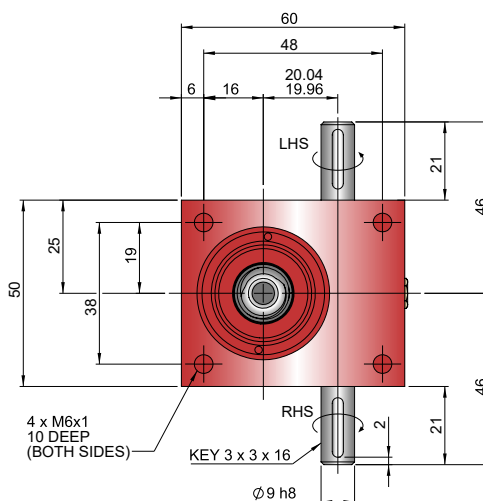

CMR0002-C00

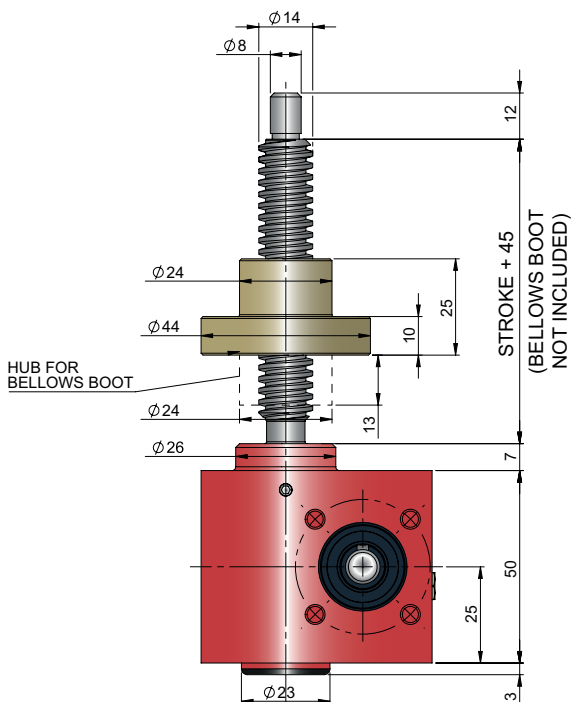
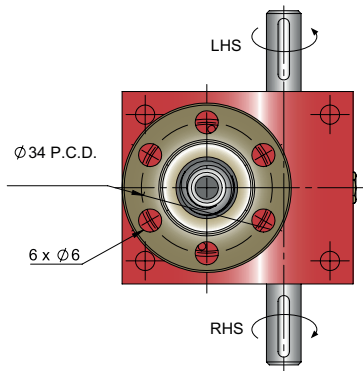

Column Strength

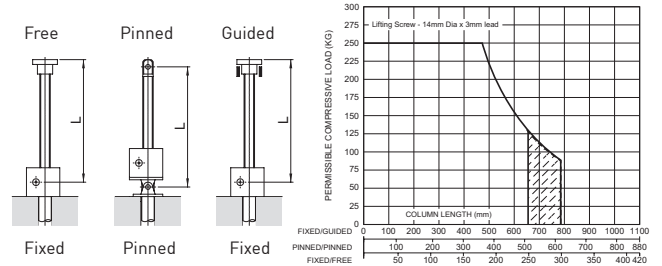

Critical Screw Speed

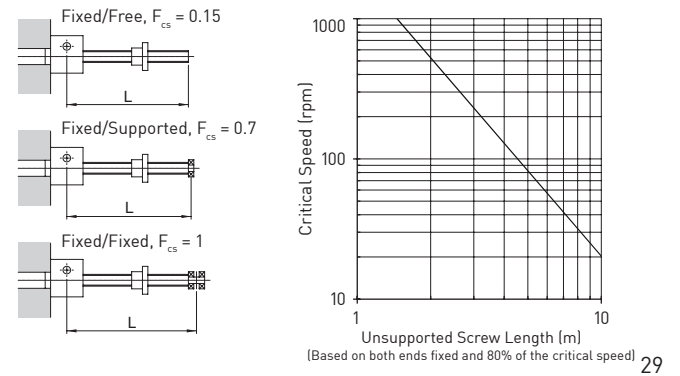

Bellows Boot

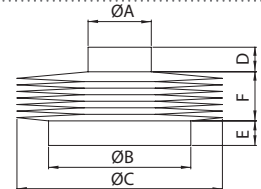

	ØA	ØB	ØC	D	E
CMT0002	24	26	100	10	7
CMT0002 (Rod End)	16	26	100	10	7
CMR0002	24	26	100	10	7

Stroke	1 - 500	501 - 1000	1001 - 1500	1500 - 2000
F	30	60	90	170*

Accessories & Options

	Anti-Backlash		End Fittings		Rotary Limit Switch Adaptor
	Anti-Rotation (Keyed)		Limit Switches		Double Hub Nut
	Safety Nut		Motor Adaptors		Drives
	Trunnion Mounts		Corrosion Protection		Secondary Guide



## CMR0005-C00

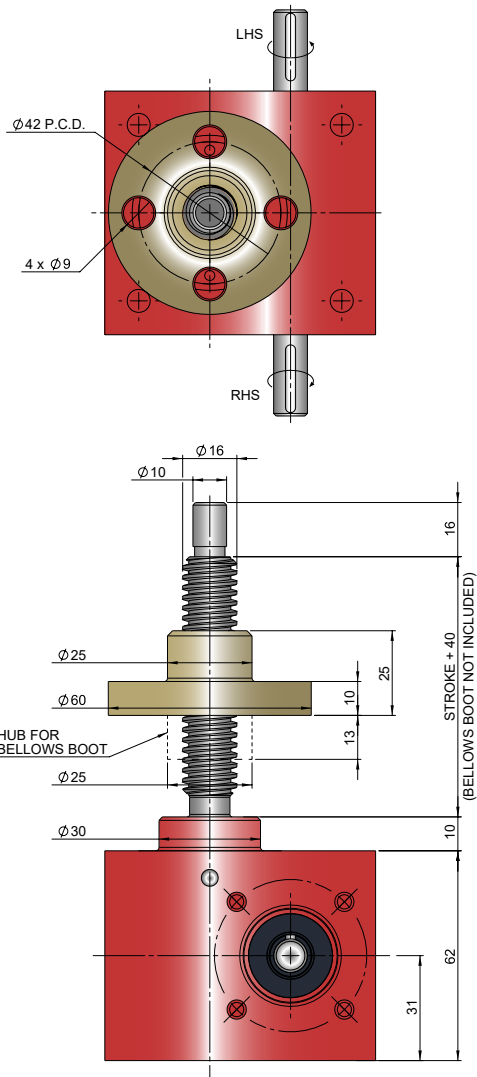

### Column Strength

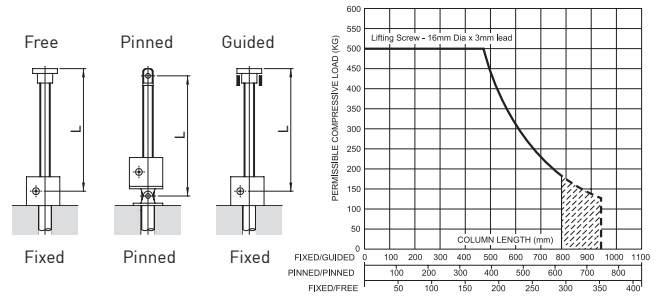

### Critical Screw Speed

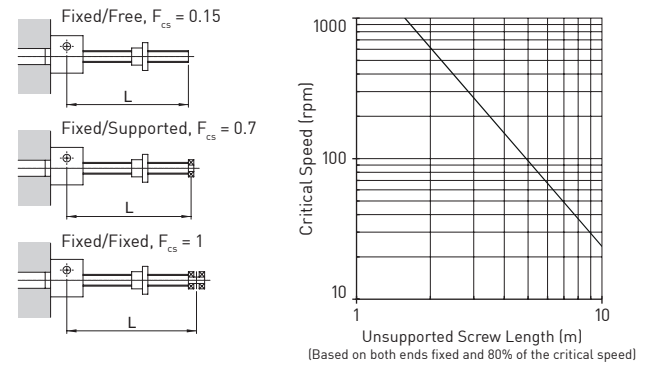

### Bellows Boot

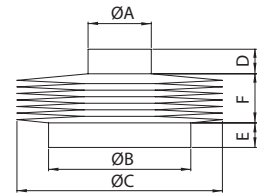

	$\phi A$	$\phi B$	$\phi C$	D	E
CMT0005	25	30	100	13	10
CMT0005 (Rod End)	19	30	100	13	10
CMR0005	25	30	100	13	10

Stroke	1 - 500	501 - 1000	1001 - 1500	1500 - 2000
F	30	60	90	170*

### Accessories & Options

	Anti-Backlash		End Fittings		Rotary Limit Switch Adaptor
	Anti-Rotation (Keyed)		Limit Switches		Double Hub Nut
	Safety Nut		Motor Adaptors		Drives
	Trunnion Mounts		Corrosion Protection		Secondary Guide



## Performance

Screw Jack Model	CM-0010	
Capacity	kN	10
Lead Screw	Diameter (mm)	20
	Lead (mm)	5   10
Gear Ratios	Option 1	5:1
	Option 2	20:1
Turn of worm for travel of lead screw	Option 1   1 Turn	1mm   2mm
	Option 2   4 Turn	1mm   2mm
Maximum Input Power (kW)	Option 1	0.375
	Option 2	0.19
Start up torque at full load (Nm)	Option 1	6.8   9.4
	Option 2	3.0   4.1
Maximum Through Torque (Nm)	Option 1	20.4
	Option 2	9.0
Static Efficiency	Option 1	0.236   0.339
	Option 2	0.113   0.192
Dynamic Efficiency	Option 1	0.306   0.424
	Option 2	0.194   0.268
Lead Screw Restraining Torque (Nm)	-	22   30
Worm Shaft Radial Load (N)		325
Maximum Input Speed (rpm)	-	1800
Gear Case Material		Aluminium
Weight (kg) – stroke = 150mm	Translating	3.0
	Rotating	3.1
Weight (kg) – per extra 25mm	Translating	0.11
	Rotating	0.05

## CMT0010 Closed Heights

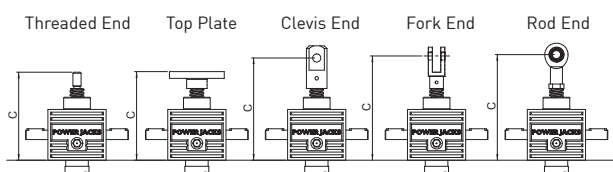

Closed Height 'C'	Threaded End	Top Plate	Clevis End	Fork End	Rod End
CMT0010	130	130	150	153	155
Stroke (mm)	With Bellow Boots [B]				
0 - 500	150	150	170	173	175
501 - 1000	180	180	200	203	205
1001 - 1500	210	210	230	233	235
1501 - 2000	290	290	310	313	315

## CMT0010 Stop Nut



Stop nut provides a full power mechanical stop at the end of the lead screw. To be used as a safety feature in emergency conditions.  
SN = Stroke + 25mm

**Note:**

1. All dimension in millimetres unless otherwise stated.
2. Designs subject to change without notice.

## CMT0010-C00

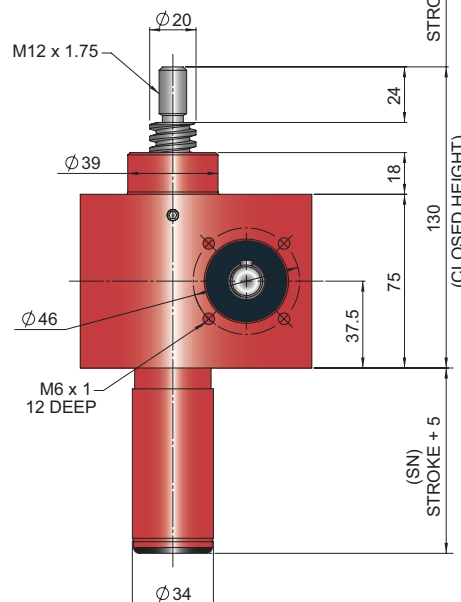
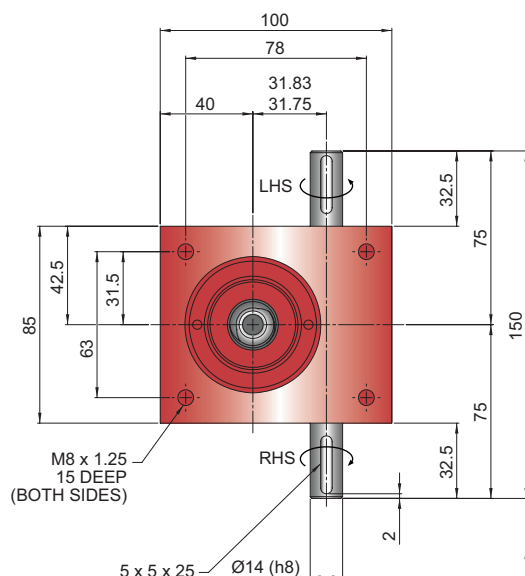



CMR0010-C00

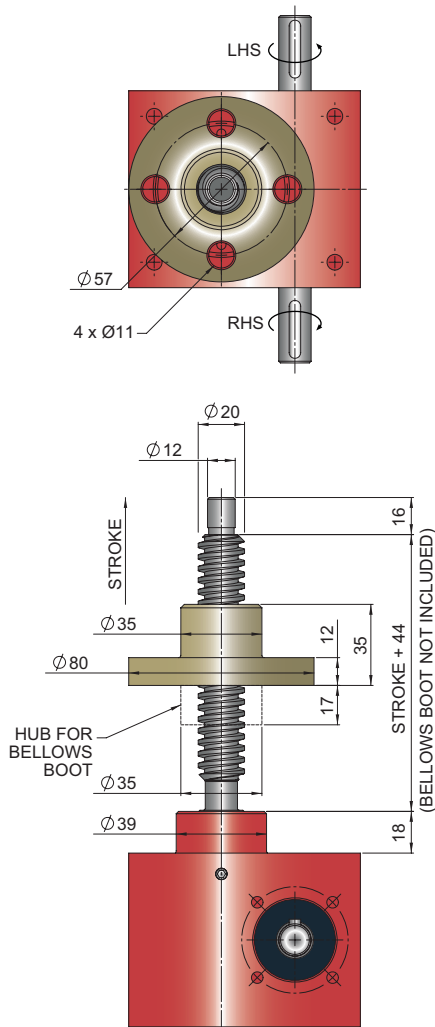

Column Strength

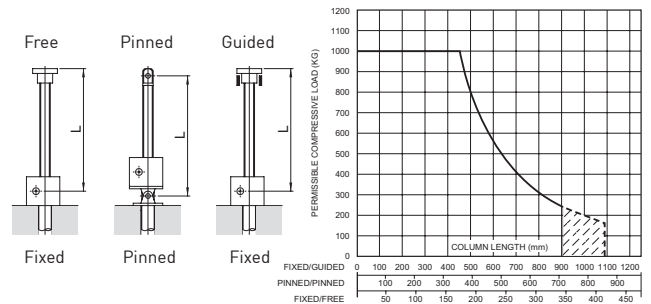

Critical Screw Speed

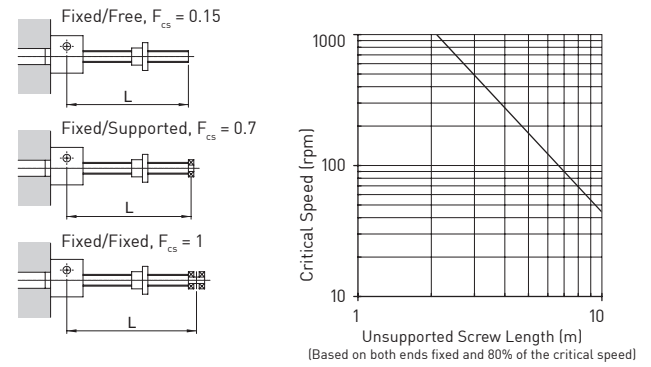

Bellows Boot

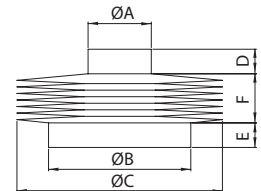

	ØA	ØB	ØC	D	E
CMT0010	30	39	110	15	15
CMT0010 (Rod End)	22	39	110	15	15
CMR0010	35	39	110	15	15

Stroke	1 - 500	501 - 1000	1001 - 1500	1500 - 2000
F	30	60	90	170*

Accessories & Options

	Anti-Backlash		End Fittings		Rotary Limit Switch Adaptor
	Anti-Rotation (Keyed)		Limit Switches		Double Hub Nut
	Safety Nut		Motor Adaptors		Drives
	Trunnion Mounts		Corrosion Protection		Secondary Guide

## Performance

Screw Jack Model	CM-0025	
Capacity	kN	25
Lead Screw	Diameter (mm)	30
	Lead (mm)	6   12
Gear Ratios	Option 1	6:1
	Option 2	24:1
Turn of worm for travel of lead screw	Option 1   1 Turn	1mm   2mm
	Option 2   4 Turn	1mm   2mm
Maximum Input Power (kW)	Option 1	1.5
	Option 2	0.375
Start up torque at full load (Nm)	Option 1	19.8   26.4
	Option 2	8.7   11.7
Maximum Through Torque (Nm)	Option 1	59.4
	Option 2	26.1
Static Efficiency	Option 1	0.201   0.302
	Option 2	0.113   0.171
Dynamic Efficiency	Option 1	0.264   0.383
	Option 2	0.167   0.242
Lead Screw Restraining Torque (Nm)	-	76   102
Worm Shaft Radial Load (N)		380
Maximum Input Speed (rpm)	-	1800
Gear Case Material		SG Iron
Weight (kg) - stroke = 150mm	Translating	8.3
	Rotating	8.7
Weight (kg) - per extra 25mm	Translating	0.21
	Rotating	0.11

## CMT0025 Closed Heights

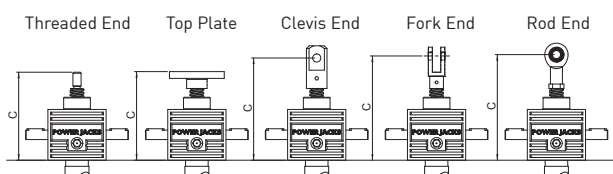

Closed Height 'C'	Threaded End	Top Plate	Clevis End	Fork End	Rod End
CMT0025	145	145	170	195	192
Stroke (mm)	With Bellow Boots (B)				
0 - 500	165	165	190	215	212
501 - 1000	190	190	215	240	237
1001 - 1500	215	215	240	265	262
1501 - 2000	245	245	270	295	292

## CMT0025 Stop Nut



Stop nut provides a full power mechanical stop at the end of the lead screw. To be used as a safety feature in emergency conditions.  
SN = Stroke + 21mm

**Note:**

1. All dimension in millimetres unless otherwise stated.
2. Designs subject to change without notice.

## CMT0025-C00

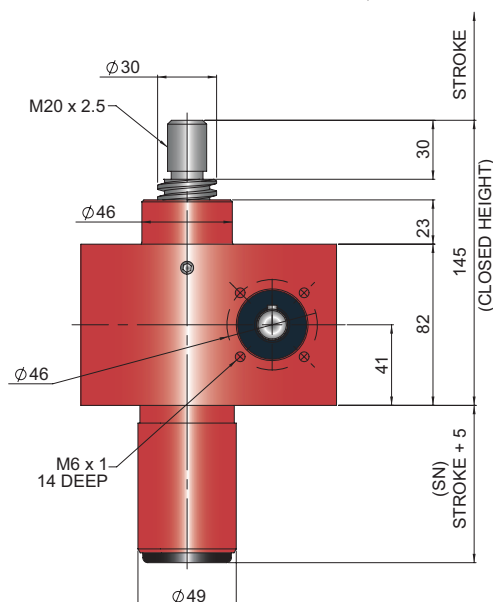
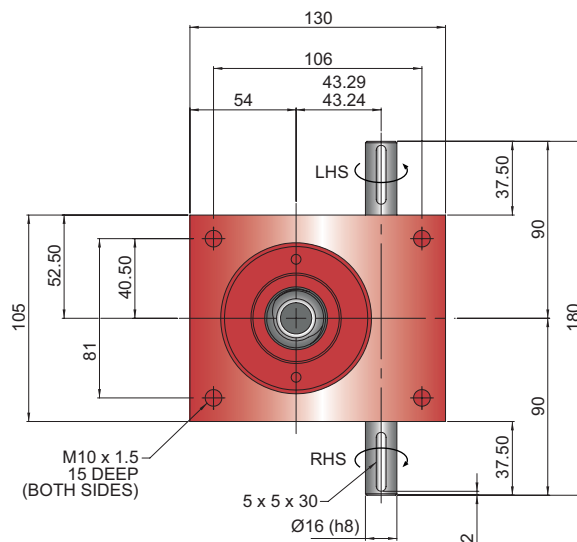

CMR0025-C00

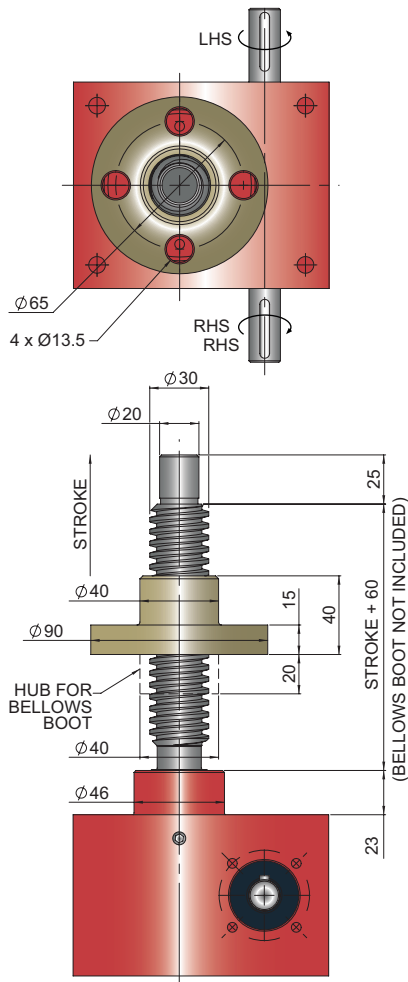

Column Strength

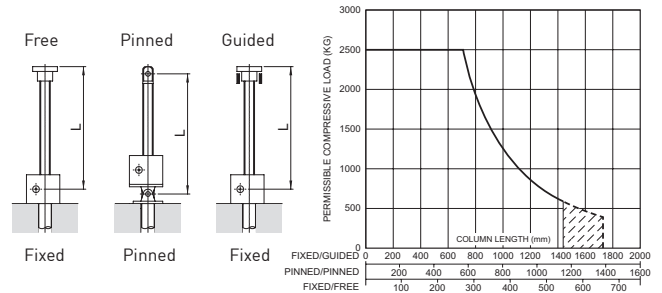

Critical Screw Speed

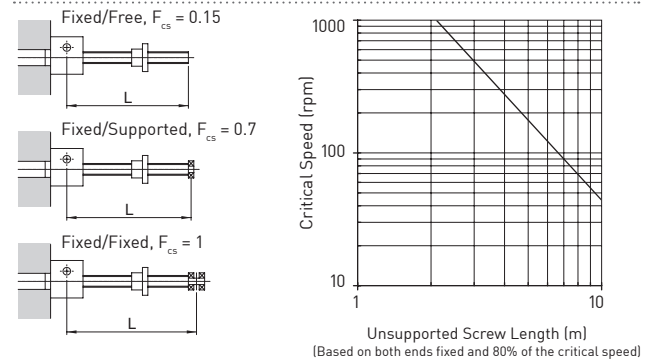

Bellows Boot

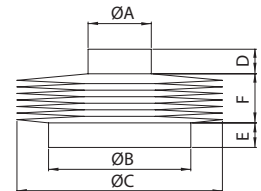

	ØA	ØB	ØC	D	E
CMT0025	40	46	120	15	15
CMT0025 (Rod End)	35	46	120	15	15
CMR0025	40	46	120	15	15

Stroke	1 - 500	501 - 1000	1001 - 1500	1500 - 2000
F	30	55	80	110*

Accessories & Options

	Anti-Backlash		End Fittings		Rotary Limit Switch Adaptor
	Anti-Rotation (Keyed)		Limit Switches		Double Hub Nut
	Safety Nut		Motor Adaptors		Drives
	Trunnion Mounts		Corrosion Protection		Secondary Guide



CMR0050-C00

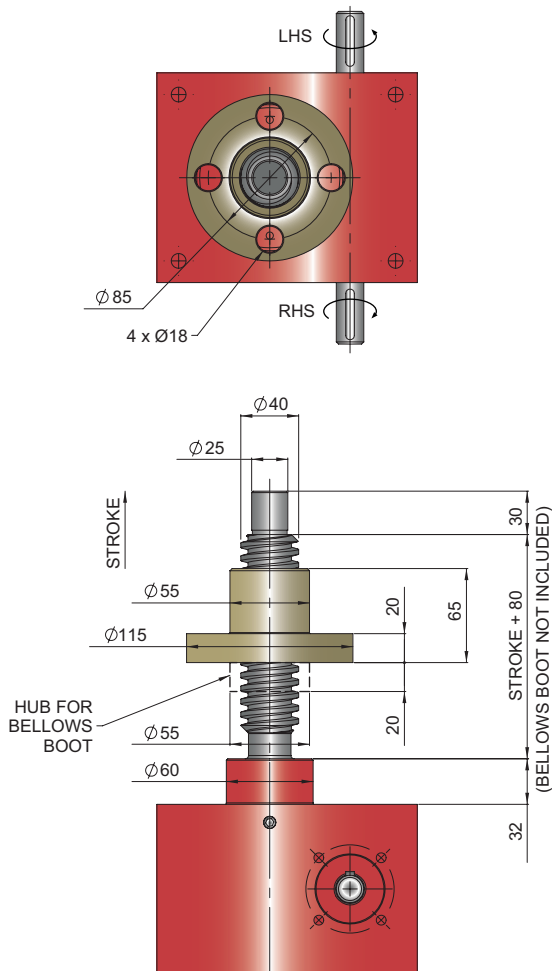

### Column Strength

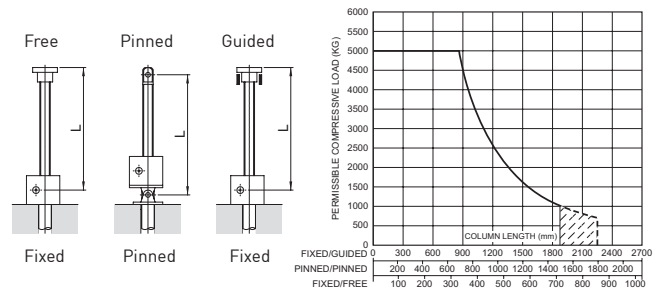

### Critical Screw Speed

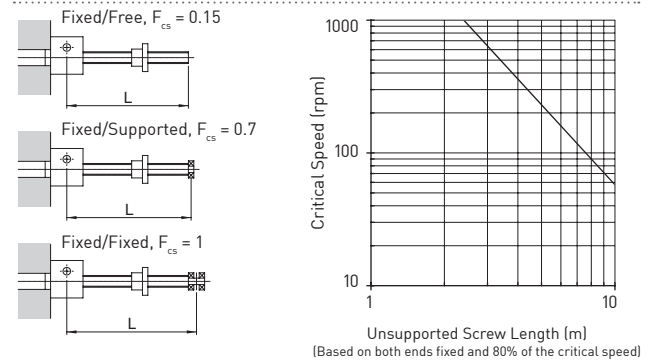

### Bellows Boot

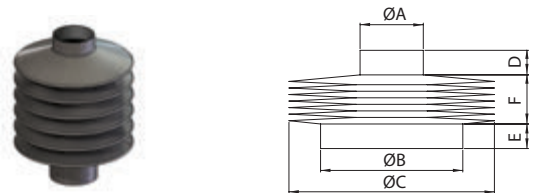

	ØA	ØB	ØC	D	E
CMT0050	50	60*	140	15	15
CMT0050 (Rod End)	42	60	140	15	15
CMR0050	55	60	140	15	15

Stroke	1 - 500	501 - 1000	1001 - 1500	1500 - 2000
F	30	50	75	140**

### Accessories & Options

	Anti-Backlash		End Fittings		Rotary Limit Switch Adaptor
	Anti-Rotation (Keyed)		Limit Switches		Double Hub Nut
	Safety Nut		Motor Adaptors		Drives
	Trunnion Mounts		Corrosion Protection		Secondary Guide

## Performance

Screw Jack Model		CM-0100	
Capacity	kN	100	
Lead Screw	Diameter (mm)	55	
	Lead (mm)	12	24
Gear Ratios	Option 1	8:1	
	Option 2	24:1	
Turn of worm for travel of lead screw	Option 1   1 Turn	1.5mm	3mm
	Option 2   4 Turn	2mm	4mm
Maximum Input Power (kW)	Option 1	3.75	
	Option 2	1.125	
Start up torque at full load (Nm)	Option 1	115.9	156.6
	Option 2	60.5	81.9
Maximum Through Torque (Nm)	Option 1	347.7	
	Option 2	181.5	
Static Efficiency	Option 1	0.206	0.305
	Option 2	0.132	0.195
Dynamic Efficiency	Option 1	0.272	0.388
	Option 2	0.190	0.271
Lead Screw Restraining Torque (Nm)	-	575	780
Worm Shaft Radial Load (N)		1000	
Maximum Input Speed (rpm)	-	1800	
Gear Case Material		SG Iron	
Weight (kg) - stroke = 150mm	Translating	19.5	
	Rotating	20.2	
Weight (kg) - per extra 25mm	Translating	0.32	
	Rotating	0.19	

## CMT0100 Closed Heights

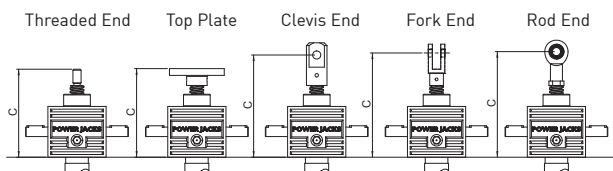

Closed Height 'C'	Threaded End	Top Plate	Clevis End	Fork End	Rod End
CMT0100	250	250	295	354	335
Stroke (mm)	With Bellow Boots (B)				
0 - 500	270	270	315	374	355
501 - 1000	290	290	335	394	375
1001 - 1500	315	315	360	419	400
1501 - 2000	380	380	425	484	465

## CMT0100 Stop Nut



Stop nut provides a full power mechanical stop at the end of the lead screw. To be used as a safety feature in emergency conditions.  
SN = Stroke + 37mm

**Note:**

1. All dimension in millimetres unless otherwise stated.
2. Designs subject to change without notice.

## CMT0100-C00

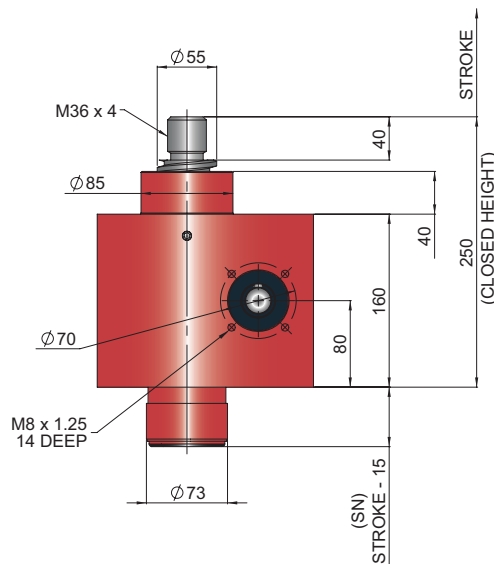
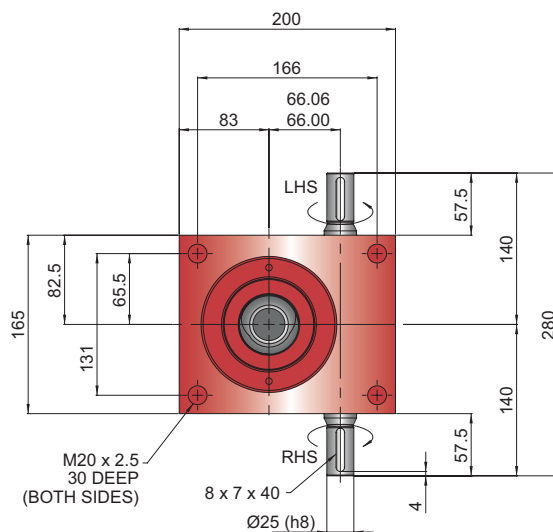

CMR0100-C00

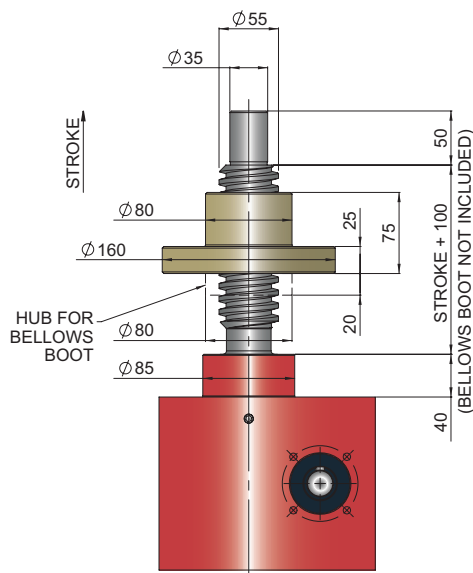
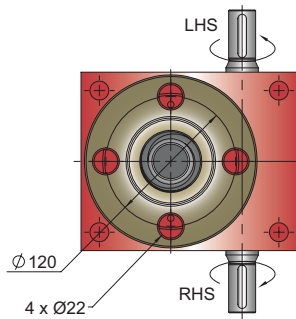

Column Strength

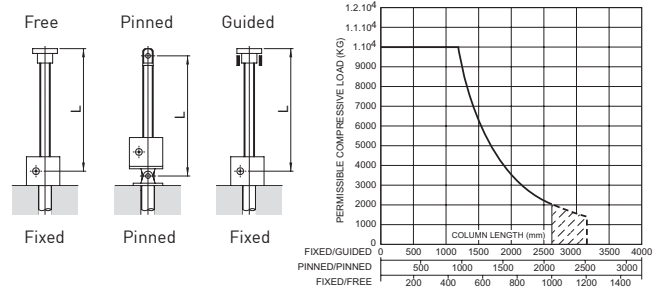

Critical Screw Speed

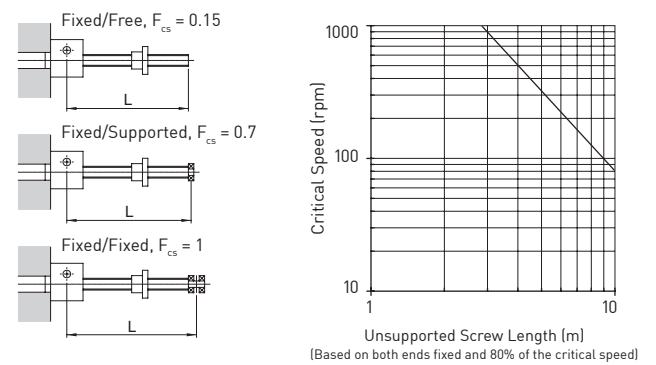

Bellows Boot

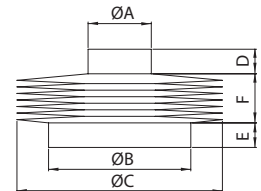

	ØA	ØB	ØC	D	E
CMT0100	65	85	150	15	15
CMT0100 (Rod End)	58	85	150	15	15
CMR0100	80	85	150	15	15

Stroke	1 - 500	501 - 1000	1001 - 1500	1500 - 2000
F	30	50	75	140*

Accessories & Options

	Anti-Backlash		End Fittings		Rotary Limit Switch Adaptor
	Anti-Rotation (Keyed)		Limit Switches		Double Hub Nut
	Safety Nut		Motor Adaptors		Drives
	Trunnion Mounts		Corrosion Protection		Secondary Guide



### Minimise Axial Backlash When Load Changes Direction

The Anti-Backlash feature provides a reliable method to regulate the axial backlash in a screw jack for applications where there is a reversal of loading from tension to compression. The amount of backlash between the screw and worm gear nut can be adjusted (adjust shell cap) to a desired amount or a practical minimum. To avoid binding and excessive wear do not adjust backlash to less than 0.025mm.

The Anti-Backlash feature also acts as a safety device, providing dual nut load carrying unit, when the worm gear becomes worn.

A visual wear indicator is included as standard on all models and a "feeler" gauge can be used to measure the wear. This can be upgraded to use a sensor on request (consult Power Jacks).

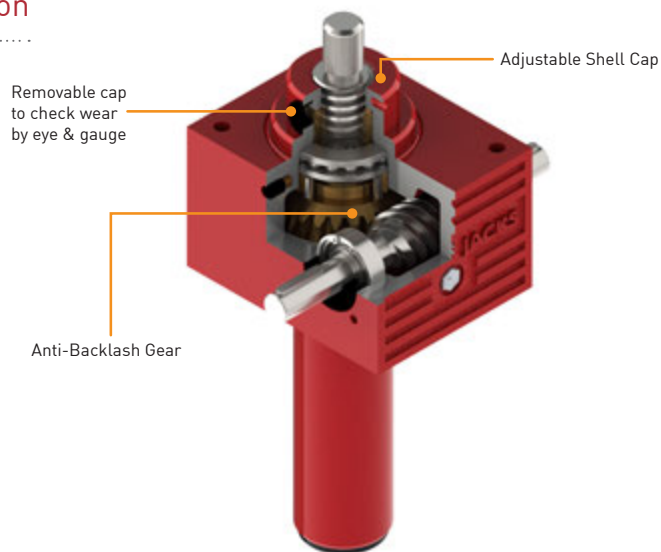

### Dimensions for Anti-Backlash

The dimensions for these screw jacks are the same as the standard units except those detailed below.

Model	CMT0002-C0A	CMT0005-C0A	CMT0010-C0A	CMT0025-C0A	CMT0050-C0A	CMT0100-C0A
A	On Request	On Request	140	155	205	260
B			32	32	40	50
C			10	22	28	37
ØD			39	55	70	85
ØE			54	70	95	110

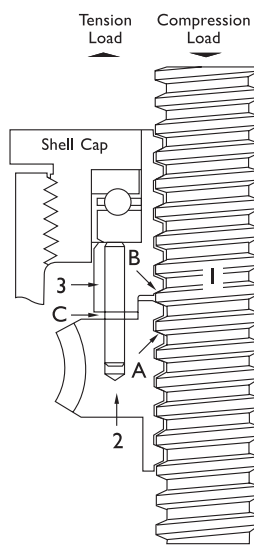
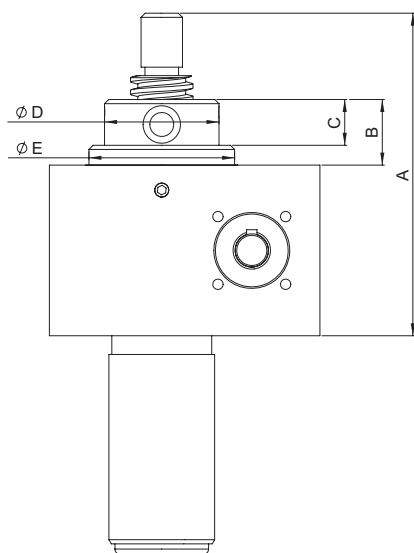

### Performance for Anti-Backlash

Model		CMT0002-C0A	CMT0005-C0A	CMT0010-C0A	CMT0025-C0A	CMT0050-C0A	CMT0100-C0A				
Lead Screw	Lead (mm)	On Request	On Request	5	10	6	12	9	18	12	24
Start-Up Torque at Full Load (Nm)	Gear Ratio Option 1			7.5	10.4	21.9	29.2	62	85	129	175
	Gear Ratio Option 2			3	4.6	9.8	13.0	28	39	67	90
Static Efficiency	Gear Ratio Option 1			0.212	0.305	0.181	0.272	0.192	0.283	0.185	0.274
	Gear Ratio Option 2			0.120	0.173	0.102	0.154	0.105	0.154	0.119	0.175
Dynamic Efficiency	Gear Ratio Option 1	0.275	0.381	0.238	0.344	0.253	0.358	0.245	0.349		
	Gear Ratio Option 2	0.174	0.242	0.151	0.218	0.155	0.219	0.171	0.244		
Weight (kg) - stroke = 150mm				3.4	8.8	20.2	36.8				

**Note:** Efficiency values for standard grease lubricated worm gear box and lifting screw.

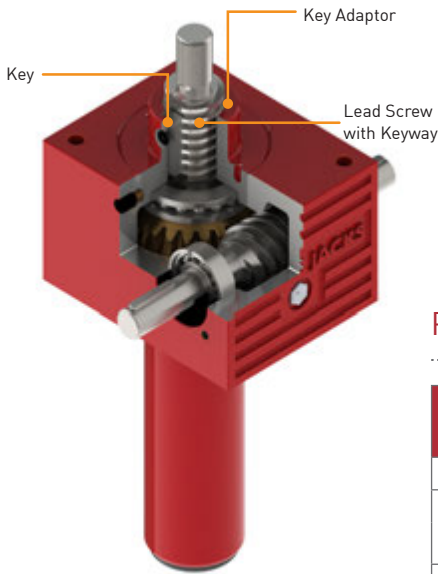

**Note:** Efficiency values for standard grease lubricated worm gear box and lifting screw. Weight is the same as standard unit.

### Linear Movement for Rotationally Unconstrained Loads

The Anti-Rotation feature for translating screw jacks stops the lead screw from rotating without the need for end fixing. This is done by keying the lifting screw.

**Benefits:**

- **Dimensions are the same as the standard translating screw jack**
- Compact unit integrates anti-rotation into gearbox
- Standard round cover pipe for easy installation
- Proven industrial anti-rotation design

### Performance for Anti-Rotation

Model		CMT 0002	CMT 0005	CMT0010		CMT0025		CMT0050		CMT0100	
Lead Screw	Lead (mm)	On Request	On Request	5	10	6	12	9	18	12	24
Start-Up Torque at Full Load (Nm)	Gear Ratio Opt 1			7.2	9.9	20.8	27.7	59	80	122	165
	Gear Ratio Opt 2			3.2	4.4	9.2	12.2	27	37	64	86
Static Efficiency	Gear Ratio Opt 1			0.224	0.322	0.191	0.287	0.203	0.299	0.196	0.290
	Gear Ratio Opt 2	0.124	0.182	0.107	0.162	0.111	0.163	0.125	0.185		
Dynamic Efficiency	Gear Ratio Opt 1	0.291	0.403	0.251	0.364	0.267	0.378	0.258	0.368		
	Gear Ratio Opt 2	0.184	0.255	0.159	0.230	0.164	0.232	0.180	0.257		

### Anti-Rotation with Anti-Backlash or Safety Nut

The anti-backlash and safety nut features can be combined with the anti-rotation feature into one screw jack. For this option the anti-rotation device is located in-line with the cover pipe.

#### Dimensions for Anti-Backlash with Anti-Rotation (Keyed)

Model	CMT0002-CKA	CMT0005-CKA	CMT0010-CKA	CMT0025-CKA	CMT0050-CKA	CMT0100-CKA
F	On Request	On Request	Stroke +5	Stroke +10	Stroke +15	Stroke +20
G			30	35.5	40	48
ØH			42.5	60	75	90

#### Dimensions for Safety Nut with Anti-Rotation (Keyed)

Load Direction - Tension

Model	CMT0002-CKR	CMT0005-CKR	CMT0010-CKR	CMT0025-CKR	CMT0050-CKR	CMT0100-CKR
F	On Request	On Request	Stroke +5	Stroke +10	Stroke +15	Stroke +20
G			35	50	59	57
ØH			45	55	70	89

DETAIL A = Same as standard CMT screw jack

Load Direction - Compression

Model	CMT0002-CKS	CMT0005-CKS	CMT0010-CKS	CMT0025-CKS	CMT0050-CKS	CMT0100-CKS
F	On Request	On Request	Stroke +5	Stroke +10	Stroke +15	Stroke +20
G			30	35.5	40	48
ØH			42.5	60	75	90

DETAIL A = Same as standard safety nut screw jack with compression load (Refer P44)

### Performance for Anti-Rotation with Anti-Backlash or Safety Nut

Model		CMT 0005	CMT 0010	CMT0010		CMT0025		CMT0050		CMT0100	
Lead Screw	Lead (mm)	On Request	On Request	5	10	6	12	9	18	12	24
Start-Up Torque at Full Load (Nm)	Gear Ratio Opt 1			8.3	11.5	24.8	33.0	65.6	89.3	136	184
	Gear Ratio Opt 2			3.8	5.3	10.3	13.7	30.0	40.9	70.3	95.2
Static Efficiency	Gear Ratio Opt 1			0.201	0.290	0.172	0.258	0.182	0.269	0.176	0.263
	Gear Ratio Opt 2	0.114	0.164	0.097	0.146	0.100	0.146	0.113	0.166		
Dynamic Efficiency	Gear Ratio Opt 1	0.261	0.362	0.226	0.330	0.240	0.340	0.233	0.332		
	Gear Ratio Opt 2	0.165	0.230	0.143	0.207	0.147	0.208	0.162	0.232		
Weight (kg) - stroke = 150mm				3.15		8.75		20		37.3	

**Note:** Efficiency values for standard grease lubricated worm gear box and lifting screw. Anti-Rotation with Safety Nut performance is the same as the Anti-Rotation unit.

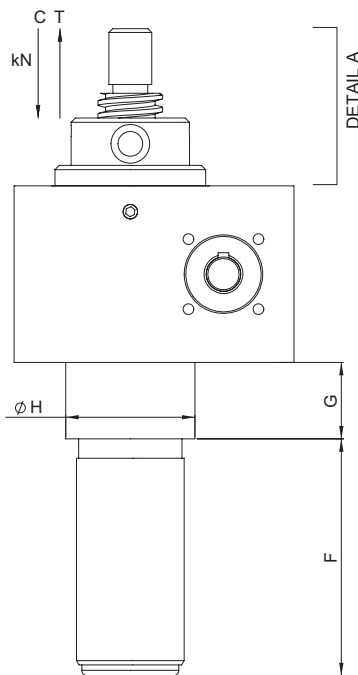

## Extra Safety for Critical Applications

Power Jacks machine screw jacks can be fitted with a safety nut, which provides 2 safety roles:

1. In the event of excessive wear on the nut thread the load will be transferred from the standard nut to the safety nut. This will also provide visual wear indication as the gap between the safety nut decreases to zero as the standard lifting nut wears.
2. In the unlikely event of nut thread failure the safety nut will sustain the load. The safety of industrial and human cargo is therefore improved.

There are several configurations for each safety nut device as they only work in one load direction. For this reason when ordering please supply a sketch of your application showing load directions.

## Translating Screw Jack with Safety Nut

The dimensions for these screw jacks are the same as the standard units except those detailed below.

Load Direction - Compression (C)

Model	CMT0002	CMT0005	CMT0010	CMT0025	CMT0050	CMT0100
A	On Request	On Request	140	155	205	250
B			32	33	40	40
C			10	22	28	40
ØD			39	55	70	85
ØE			54	70	95	85

DETAIL A = As per table above

DETAIL B = Same as standard CMT screw jack (Dimension F, G, ØH not applicable)

Load Direction - Tension

Model	CMT0002	CMT0005	CMT0010	CMT0025	CMT0050	CMT0100
F	On Request	On Request	Stroke + 5	Stroke + 10	Stroke + 15	Stroke + 20
G			35	50	59	57
ØH			45	55	70	89

DETAIL A = Same as standard CMT screw jack (Dimension A, B, C, ØD, ØE not applicable)

DETAIL B = As per table above

Model	CMT0002	CMT0005	CMT0010	CMT0025	CMT0050	CMT0100
Weight (kg)	On Request	On Request	2.9	8.0	18.6	34.7

## Rotating Screw Jack with Safety Nut

The dimensions for these screw jacks are the same as the standard units except those detailed below. A bellows boot hub can be provided on the flanged half of the safety nut.

Model	CMR0002	CMR0005	CMR0010	CMR0025	CMR0050	CMR0100
A	On Request	On Request	Stroke +76	Stroke +95	Stroke +140	Stroke +170
B			66.5	75	125	145
C			30	33.5	58	67
D			12	15	20	25
ØE			80	90	115	160
ØF			35	40	55	80
G			4 x Ø11 Ø57 PCD	4 x Ø13.5 Ø65 PCD	4 x Ø18 Ø85 PCD	4 x Ø22 Ø120 PCD

PCD = Pitch Circle Diameter

Nut must be orientated correctly for load direction

Model	CMT0002	CMT0005	CMT0010	CMT0025	CMT0050	CMT0100
Weight (kg)	On Request	On Request	3.3	9.0	21.1	42.2

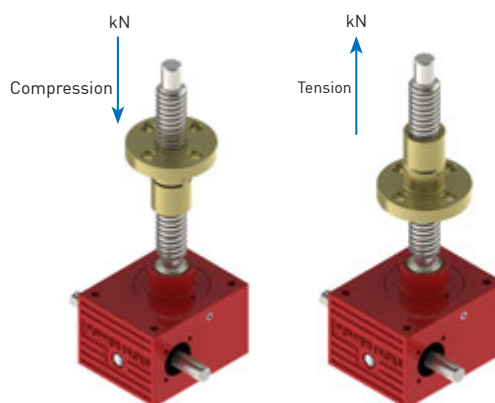

**All Safety Nuts are BS EN 1570 Compliant**

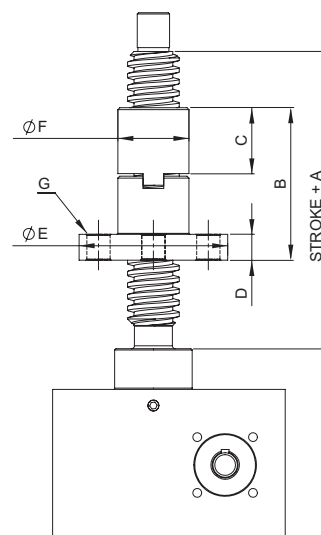
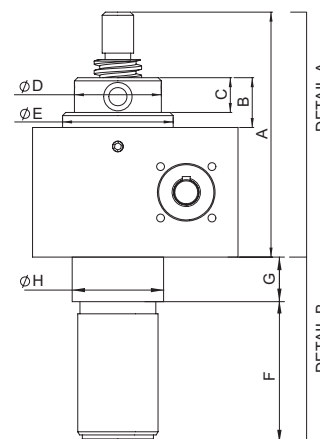
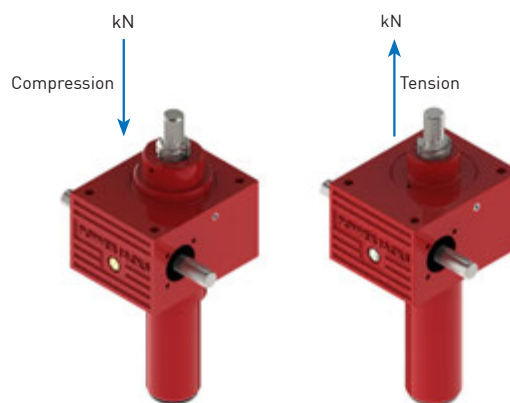

Top Plate

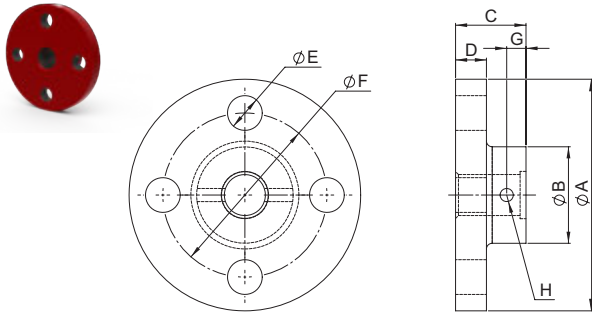

Capacity	2.5kN	5kN	10kN	100kN	50kN	100kN
ØA	Ø50	Ø65	Ø80	Ø100	Ø120	Ø150
ØB	Ø24	Ø25	Ø30	Ø40	Ø50	Ø65
C	16	21	24	31.5	36.5	42
D	6	8	10	12	16	20
ØE	Ø6.5	Ø9	Ø11	Ø13.5	Ø18	Ø22
ØF (PCD)	Ø40	Ø45	Ø55	Ø70	Ø85	Ø110
G	5	7	8	10	10	12
H	M4 x 0.7	M5 x 0.8	M6 x 1	M8 x 1.25	M8 x 1.25	M10 x 1.5
Weight (kg)	0.116	0.225	0.43	0.79	1.5	2.82

PCD = Pitch Circle Diameter

Clevis End

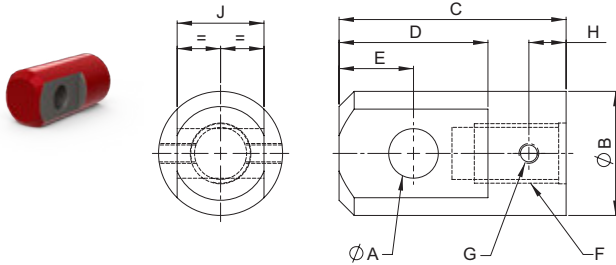

Capacity	2.5kN	5kN	10kN	25kN	50kN	100kN
ØA	Ø8	Ø10	Ø12	Ø16	Ø20	Ø22
ØB	Ø24	Ø25	Ø30	Ø40	Ø50	Ø65
C	40	56	63	79.5	99.5	120
D	20	30	36	46	60	66
E	10	15	18	23	30	33
F	M8 X 1.25 16 Deep	M10 X 1.5 22 Deep	M10 X 1.75 25 Deep	M20 X 2.5 32 Deep	M24 X 3 37 Deep	M36 X 4 42 Deep
G	M4 X 0.7	M5 X 0.8	M6 X 1	M8 X 1.25	M8 X 1.25	M10 X 1.5
H	8	10	15	15	15	20
J	12	15	20	30	35	40
Weight (kg)	0.1	0.15	0.26	0.57	1.0	2.1

Fork End

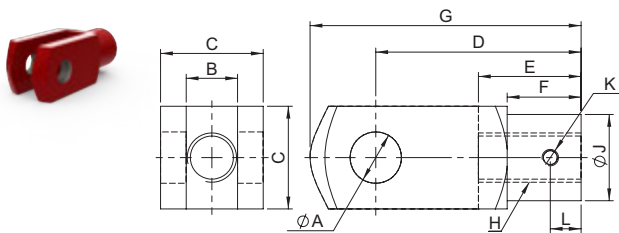

Capacity	2.5kN	5kN	10kN	25kN	50kN	100kN
ØA	Ø8	Ø10	Ø12	Ø20	Ø25	Ø35
B	8	10	12	20	25	35
C	16	20	24	40	50	70
D	32	40	48	80	100	144
E	16	20	24	40	50	72
F	12	15	18	30	36	54
G	42	52	62	105	132	188
H	M8 x 1.25	M10 x 1.5	M12 x 1.75	M20 x 2.5	M24 x 3	M36 x 4
ØJ	Ø14	Ø18	20	34	42	60
K	M4 x 0.7	M5 x 0.8	M6 x 1	M8 x 1.25	M8 x 1.25	M10 x 1.5
L	6	6.5	10	10	15	20
Weight (kg)	0.037	0.054	0.12	0.55	1.1	2.93

Rod End

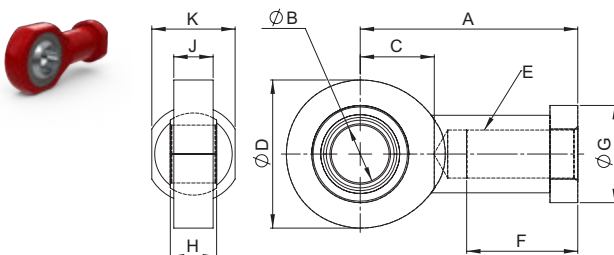

Capacity	2.5kN	5kN	10kN	25kN	50kN	100kN
A	36	43	50	77	94	125
ØB	Ø8	Ø10	Ø12	Ø20	Ø25	Ø35
C	13	15	18	27	32	42
ØD	Ø24	Ø29	Ø34	Ø53	Ø64	Ø82
E	M8 x 1.25	M10 x 1.5	M12 x 1.75	M20 x 1.75	M24 x 2	M36 x 3
F	15	20	20	23	48	60
ØG	Ø16	Ø19	Ø22	Ø35	Ø42	Ø58
H	8	9	10	16	20	25
J	6	7	8	13	17	21
K	14	17	19	32	36	50
Weight (kg)	0.046	0.061	0.096	0.35	0.64	1.3

Note: Lead screw threaded end made to suit rod end.

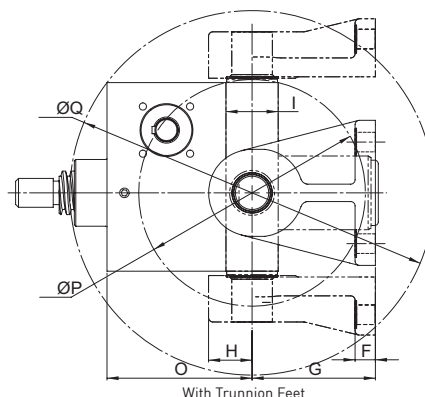
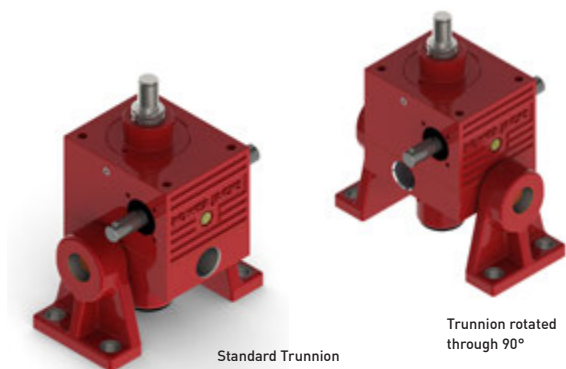

Trunnion mounts provide a pivot point at the gearbox of the screw jack.

- 2 Pivot Plane Options
- Supplied with or without Trunnion Feet
- Option of Male or Female Trunnions
- Trunnion mounts can be mounted on either side of the screw jacks gearbox

When the trunnions are on the same side as the worm shaft multiple screw jacks can be linked in line with a drive shaft and pivot around a common axis.

The trunnion mounts are connected to the screw jacks gearbox with 4 bolts.

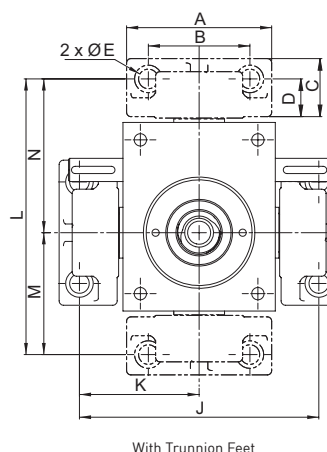

Model	CMT0002 CMR0002	CMT0005 CMR0005	CMT0010 CMR0010	CMT0025 CMR0025	CMT0050 CMR0050	CMT0100 CMR0100
A			70	100	140	170
B			42	70	100	120
C			34	40	55	70
D			21	26	35.5	43.5
ØE			11	13.5	18	22
F			12	14	20	25
G			65	85	120	130
H			20	30	42.5	47.5
I			30	36	50	60
J			134	164	226	265
K			67	82	113	132.5
L			149	189	261	300
M	On Request	On Request	64.5	83.5	118.5	133
N			84.5	105.5	142.5	167
O			90	100	142	190
ØP			124	156.5	210	242
ØQ			216.5	251.5	350	446.5
ØR			20 f7	25 f7	35 f7	45 f7
ØS			30	35	47	58
T			20	20	20	35
U			2.5	2.5	2.5	5
ØV			20	25	35	45
ØW			30	35	47	74
X			1.5	1.5	2	2
Y			16.5	16.5	26	32
Z			22	26	39	40

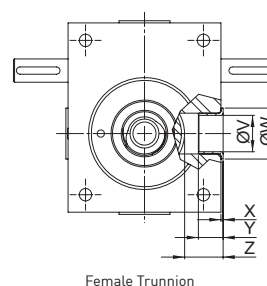
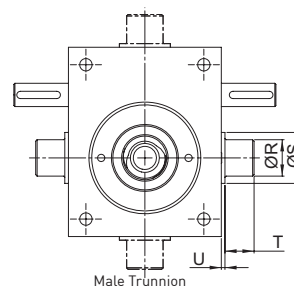

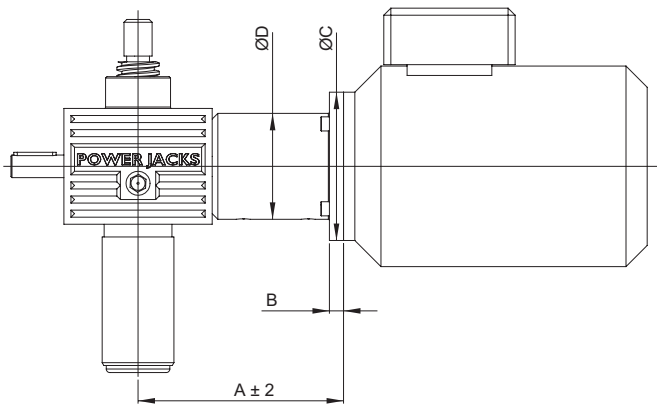

Mount an electric motor to the C-Series screw jack with the extensive range of motor adaptors designed to be used in conjunction with a flexible jaw coupling that connects the motor drive shaft to the screw jacks worm shaft.

Model	CMT0002 CMR0002					
IEC Frame	A	B	ØC	ØD	Coupling	Available
On Request	On Request	On Request	On Request	On Request	On Request	On Request

Model	CMT0005 CMR0005					
IEC Frame	A	B	ØC	ØD	Coupling	Available
On Request	On Request	On Request	On Request	On Request	On Request	On Request

Model	CMT0010 CMR0010					
IEC Frame	A	B	ØC	ØD	Coupling	Available
63 B5 D140	122.5	10	140	65	19/24 A14 A11	OR
63 B14 C90	122.5	10	90	65	19/24 A14 A11	S
71 B5 D160	122.5	10	160	65	19/24 A14 A14	OR
71 B14 C105	122.5	10	105	65	19/24 A14 A14	S
80 B5 D200	132.5	12	200	65	19/24 A14 A19	OR
80 B14 C120	132.5	12	120	65	19/24 A14 A19	S

Model	CMT0025 CMR0025					
IEC Frame	A	B	ØC	ØD	Coupling	Available
71 B5 D160	145.5	10	160	75	19/24 A16 A14	OR
71 B14 C105	145.5	10	105	75	19/24 A16 A14	S
80 B5 D200	145.5	12	200	75	19/24 A16 A19	OR
80 B14 C120	145.5	12	120	75	19/24 A16 A19	S
90 B5 D200	162.5	12	200	75	24/30 A16 A24	OR
90 B14 C140	162.5	12	140	75	24/30 A16 A24	S
100 B5 D250	174.5	12	250	75	24/30 A16 B28	OR
100 B14 C160	174.5	12	160	75	24/30 A16 B28	S

Model	CMT0050 CMR0050					
IEC Frame	A	B	ØC	ØD	Coupling	Available
80 B5 D200	172.5	12	200	86	19/24 A19 A19	OR
80 B14 C120	172.5	12	120	86	19/24 A19 A19	OR
90 B5 D200	192.5	12	200	95	24/30 A19 A24	OR
90 B14 C140	192.5	12	140	95	24/30 A19 A24	S
100 B5 D250	192.5	12	250	95	24/30 A19 B28	OR
100 B14 C160	192.5	12	160	95	24/30 A19 B28	S
112 B5 D250	192.5	12	250	95	24/30 A19 B28	OR
112 B14 C160	192.5	12	160	95	24/30 A19 B28	S
132 B5 D300	222.5	12	300	95	28/38 A19 B38	OR
132 B14 C200	222.5	12	200	95	28/38 A19 B38	S

Model	CMT0100 CMR0100					
IEC Frame	A	B	ØC	ØD	Coupling	Available
90 B5 D200	208.5	12	200	100	24/30 A25 B24	OR
90 B14 C140	208.5	12	140	100	24/30 A25 B24	S
100 B5 D250	218.5	12	250	100	24/30 A25 B28	OR
100 B14 C160	218.5	12	160	100	24/30 A25 B28	S
112 B5 D250	218.5	12	250	100	24/30 A25 B28	OR
112 B14 C160	218.5	12	160	100	24/30 A25 B28	S
132 B5 D300	239.5	12	300	100	28/38 A25 B38	OR
132 B14 C200	239.5	12	200	100	28/38 A25 B38	S

**Note:**

1. NEMA Motor adaptors available on request
2. Motor adaptors are for the support of motor weight only
3. OR = On Request
4. **S = Standard**

Limit switches can be mounted on the screw jacks cover pipe to signal stroke positions such as end of travel. The switch is triggered by a cam or target disc on the end of the lifting screw.

**Features:**

1. Inductive Proximity Sensors as standard. Others including electro-mechanical and safety rated available on request.
2. No contact, so no wearing parts.
3. 2 Wire sensor 24VDC for either Normally Closed (NC) or Normally Open (NO) switching.
4. Sensor has rugged one-piece Metal housing.
5. Optical setting aid
6. M12 Plug in connection for fast change-ability.
7. Sensor kit includes–sensor, mounting ring, target ring and modification to screw jack cover pipe.
8. Switch can have a fixed or adjustable mounting.
9. More sensor details in System Components section of Design Guide.



### Dimensions

Model	CMT0002	CMT0005	CMT0010	CMT0025	CMT0050	CMT0100
Switch Size	On Request	On Request	M8	M12	M12	M12
A (mm)			Stroke + 15	Stroke + 15	Stroke + 12	Stroke + 24
B (mm)			50	50	50	50
C (mm)			10	15	15	20
D (mm)			34	36	41	46
E (mm)± 5			78.5	84	89	100
F Adjustment (mm)			5	5	5	5
ØG (mm)			34	49	61	73

**Note:**

1. \*Structure dimension (C) only required when screw jack is secured on this face. Not required if secured on opposite face.
2. All dimensions in mm unless otherwise stated.
3. Dimensions subject to change without notice.

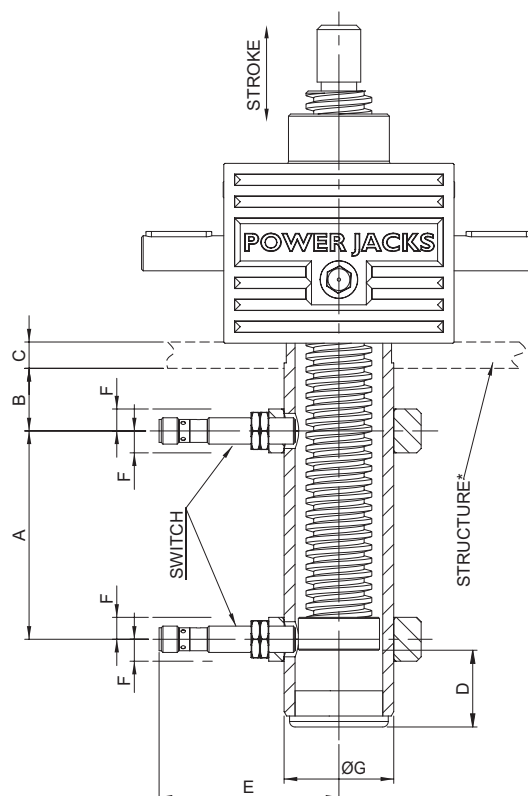



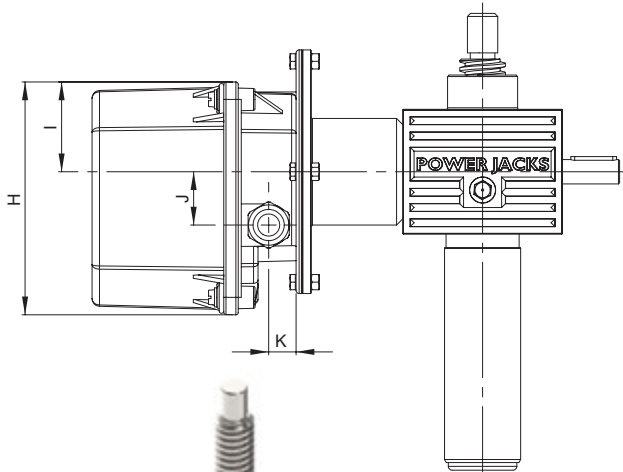
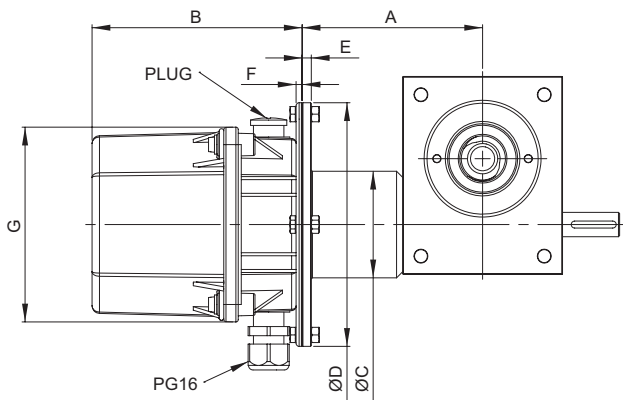

RLS-51 Rotary cam limit switches can be used as end of travel limit switches with the option of intermediate switches. Each limit switch is individually adjustable over the entire stroke of the screw jack.

- 2 to 8 limit switches in one unit
- Usable revolutions from 4 to 16000
- Switch types include:  
Changeover (Normally Closed/Open), Normally Closed, Gold or Silver contacts
- Maintenance free rotary cam gearbox
- Enclosure IP66 as standard
- Mounting options for B14 (face), B5 (flange) and B3 (foot)
- Available in 3 voltages 250VAC, 24VDC & 80VDC
- Maximum input speed 1800rpm
- Operating temperature -40°C to +80°C
- Options for potentiometer, anti-condensation heaters and encoders
- Stage technology option to VBG70

Mounted onto a screw jacks free worm shaft as an alternative where cover pipe mounted limit switches are not possible e.g. rotating screw jacks.

More RLS-51 rotary limit switch details in System Components section of Design Guide.

Type	CMT-0010 CMR-0010	CMT-0025 CMR-0025	CMT-0050 CMR-0050	CMT-0100 CMR-0100
A	109	119	139	154
ØC	86	86	86	100
ØD	120	120	120	160
E	11	11	11	10

Size	Switches				
	Revolutions	2	4	6	8
1	4.1, 6.5, 11	132	132	157	157
2	17.5, 29, 48	132	132	157	182
3	75, 125, 205	132	132	157	182
4	323, 540, 880	132	157	182	207
5	1384, 2288, 3735	132	157	182	207
6	5900, 9800, 16000	157	157	182	207

All Units					
F	G	H	I	J	K
4	128	153	59	35	18

**Note:**

1. All dimension in millimeters unless otherwise stated.
2. Designs subject to change without notice.
3. More information on RLS-51 limit switch see System Component section.
4. RLS-51 limit switch not available for 2.5kN and 5kN model screw jacks.

## E-Series Machine Screw Jack

AVAILABLE IN MANY  
STANDARD MODELS  
WITH A WIDE RANGE OF  
CAPABILITIES, THERE IS  
A STANDARD MODEL FOR  
ALMOST ANY REQUIREMENT.

**TRANSLATING SCREW JACKS**

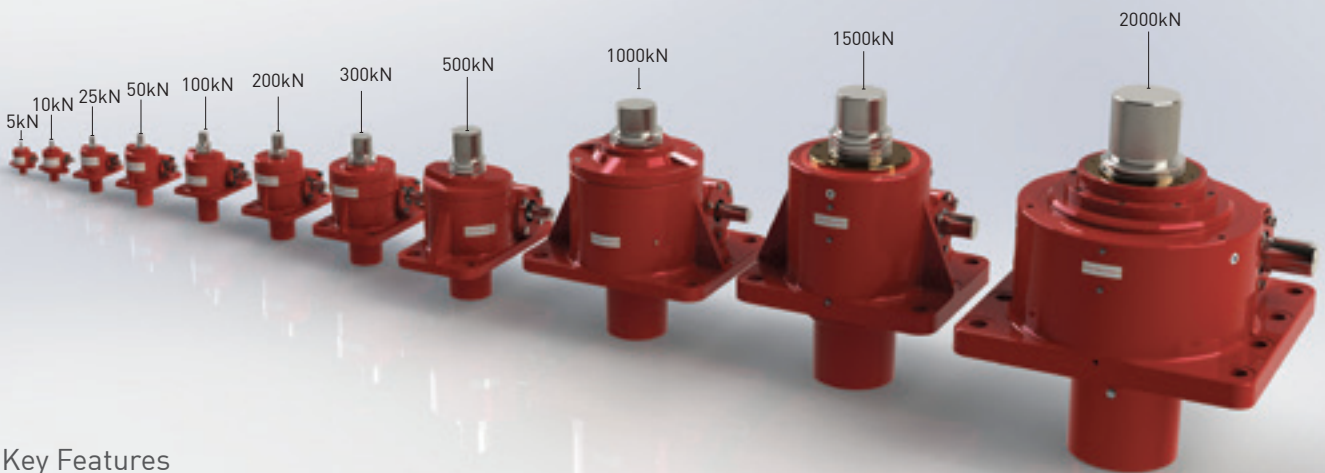

Key Features

- Standard Performance Power Jack
- Metric Single Face Machine Screw Jacks
- Capacities - 5kN to 2000 kN as standard
- Translating and Rotating Screw in Upright and Inverted types
- Precision Worm Gear Set
- 2 Gear ratios and 2 screw lead options for most sizes
- Anti-backlash and anti-rotation (keyed) options
- 6 mounting options including trunnion and double clevis
- Special custom designs available



**ROTATING SCREW JACKS**

End Fittings as Standard

1. Top Plate (shown)
2. Clevis End
3. Fork End
4. Rod End

Threaded end on screw as standard. End fittings screw on.

Bellows Boot Screw Protection  
Prevents ingress of dirt and debris onto screw threads.

Shell Cap  
Locked in place by set screws.

Precision Machined Lifting Screw available in standard material or stainless steel.

Load Bearings  
Bearings, top and bottom to take loads in tension or compression.

Accurately hobbled aluminium bronze worm gear for greater gear contact.

Worm Shaft  
Available with double or single shaft extension. In standard, plated or stainless steel material.

Thrust Bearings and Grease Seals  
At each end of worm. 5 & 10 kN models do not have separate seals.

Grease Application Point

Integrated Lubrication Systems  
Both gear set and lifting screw are grease lubricated. Grease reservoirs are in the Gearbox Housing and in the Cover Pipe. The lifting screw dips itself in grease from the Cover Pipe. Plus a small film of grease is applied via the "Forced Grease Lubrication" system directly onto the screw thread. This is where the worm shaft pushes grease through small radial holes in the gear directly onto the screw thread ensuring optimum lubrication.

Mounting Bolt Holes

Housing  
Aluminium on 5 & 10 kN models, ductile iron on 25 kN through 100 kN models, cast steel on 200 kN through 2000 kN models.

Corrosion Protection to suit all economic needs including:

- Standard Industrial Paint
- Arduous Environment Paint
- Customer Specified Paint
- Plated Finish
- Stainless Steel - refer Section-4

Cover Pipe  
Protects lifting screw threads.

### Translating Screw



Upright

Inverted

### Rotating Screw

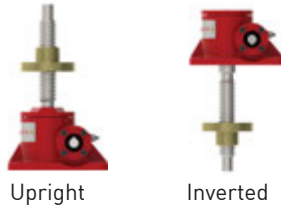

Upright

Inverted

## Typical Applications

Conventional Machine Screw Jacks are most widely used for intermittent duty cycles, as the screw jack incorporates a precision worm gear set in a rugged casting delivering positive, precise actuation. Available in a comprehensive range of materials and fittings with the option for special designs for specific application requirements. They are used in wide variety of automation applications including those in steel, automotive, communications, civil, defence, energy, glass and aerospace sectors.

## Standard Designs

The standard E-Series screw jack is available in translating and rotating screw designs in capacity sizes from 5kN to 2000kN. The design is optimised for performance, function and reliability with a highly flexible platform for customisation in addition to the standard options. The options and accessories (section-7) list is long and varied and allows you to configure a standard design that is just right for your application. These options include Anti-Backlash, Anti-Rotation (Keyed) and Safety Nut designs.

## Special Designs

We can fully customise our screw jacks so that your application can be the best.

Customisation can be anything from a small modification such as an extra bolt hole on an end fitting to a completely new design of screw jack based on our class leading technology.

For more details please see the Special Screw Jack information in Section-8 or contact us today with your requirements. Our team are looking forward to working with you.

## Selecting the Right Screw Jack

Consider all application constraints then choose a product that looks suitable for the intended application. Calculate the power and torque requirements. This is a 5 step process:

- Screw Jack Input Speed (RPM)
- Operating Input Power (kW)
- Operating Input Torque (Nm)
- Screw Jack Start-up Torque (Nm)
- Mechanical Power and Torque Check

## Systems

The screw jacks can be connected together in systems so that multiple units can be operated and controlled together. These jacking system arrangements or configurations can be built in many formats with the use of bevel gearboxes, motors, reduction gearbox, drive shafts, couplings, plummer blocks and motion control devices.

The use of bevel gearboxes allows the distribution of drive throughout a jacking system. The gearboxes come in 2,3 and 4 way drive types. See the Bevel Gearbox Section-10 for more details.

Bevel gearboxes and other system components can also be supplied in stainless steel or other corrosion resistant designs.



Two of the most popular system configurations are the 'H' and 'U' configured jacking systems. Remember that multiple screw jacks can be linked together mechanically or electrically. The latter is useful if there is no space for linking drive shafts.

If multiple machine screw jacks are connected in a mechanically linked system then the complete system may be considered self-locking. If you would like this checked consult Power Jacks. Alternatively, to be sure, include a brake on the system either as a stand alone device or as a brake motor.



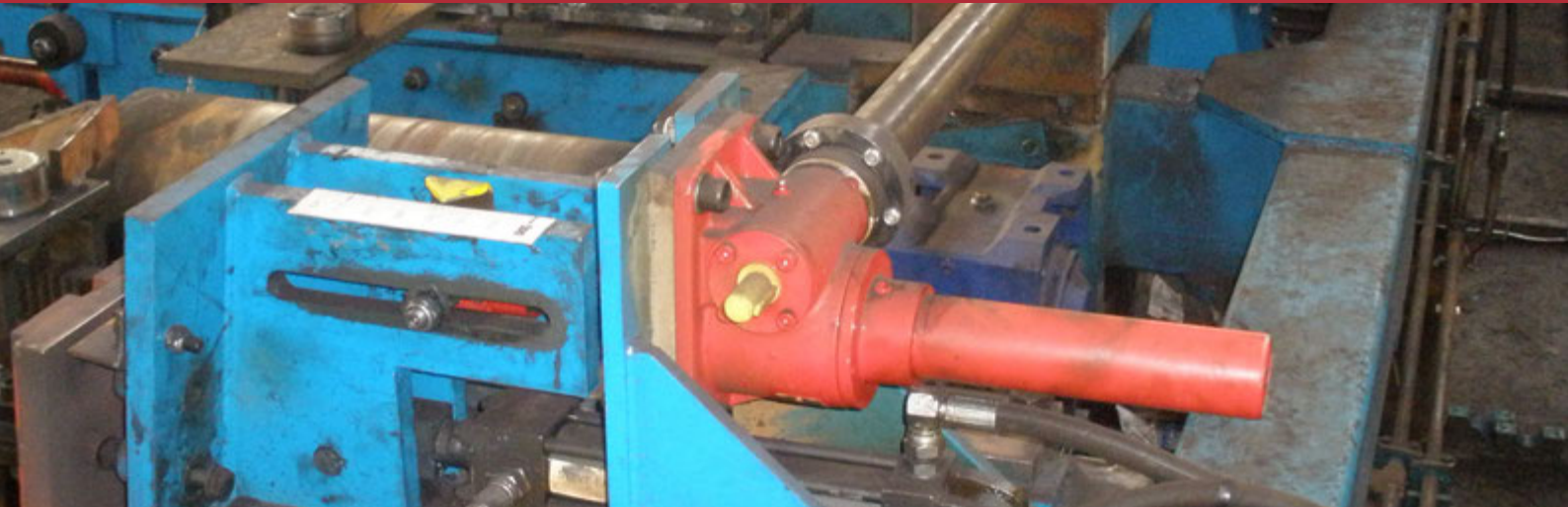

## ADJUSTABLE TABLE STOPS FOR TATA STEEL PRODUCTION

E-Series Machine Screw Jacks are installed on the adjustable table and centring stops for the Rectangular Hollow Sections (RHS) department at TATA Steel Europe 20" pipe mill in Hartlepool.

Automated adjustable stop mechanisms use 50kN E-Series translating machine screw jacks in inverted screw configuration. Each stop mechanism uses a four screw jack system that is driven by one electric motor. The electric motor is positioned in the centre of the system with 2 screw jacks either side.

A bevel gearbox is used to split the drive line to each side from the motor with self-supporting drive shafts (spacer couplings) used to connect each screw jack to the system. One screw jack in each system is fitted with an encoder for speed and position feedback, which is displayed on an electronic display.

For more application examples see the 'Power at Work' brochure or [www.powerjacks.com](http://www.powerjacks.com).



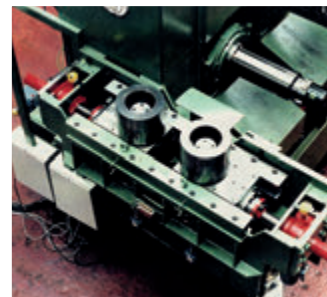
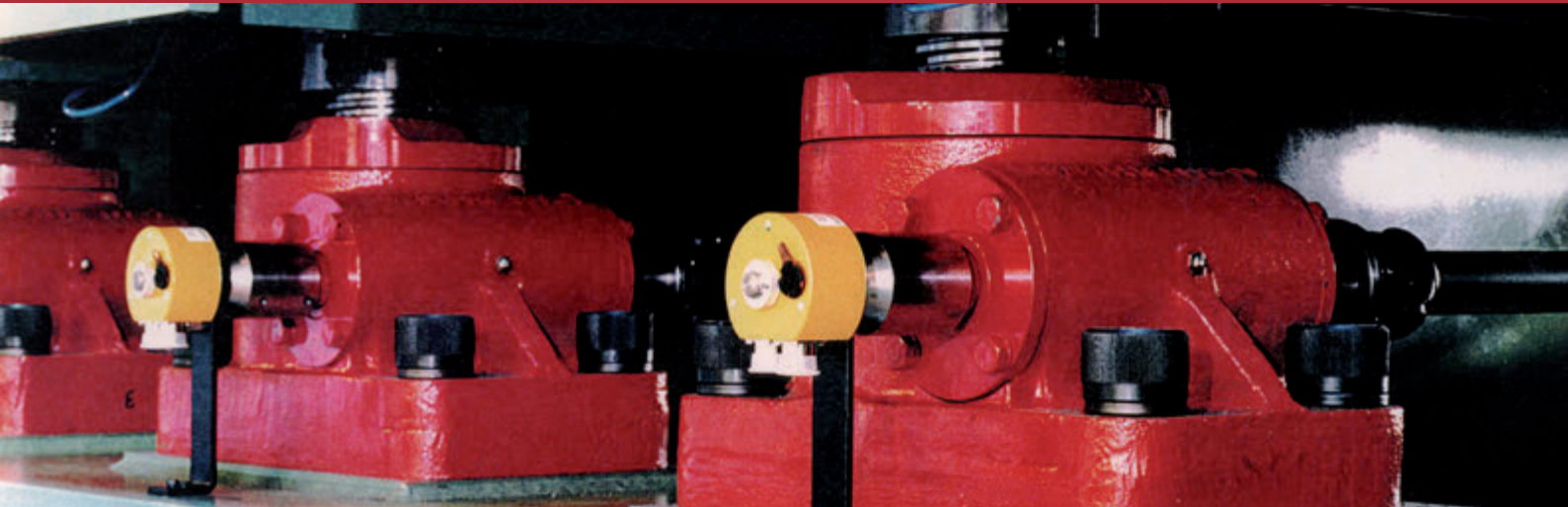

## BRONX METAL SECTION STRAIGHTENER

Variable centre straighteners for moving the centre straightening rollers, end pinch rollers and the landing legs.

A jacking system for each straightening roller has two special design screw jacks and a strengthened gearbox, rated for a 700kN dynamic capacity in compression. The pinch rollers have their position adjusted by two horizontally opposing screw jacks, driven individually by motorised helical gearboxes.

For more application examples see the 'Power at Work' brochure or [www.powerjacks.com](http://www.powerjacks.com).





## E-Series - Machine Screw Jacks - Standard Performance

Model		EMT0005 EMR0005		EMT0010 EMR0010		EMT0025 EMR0025		EMT0050 EMR0050		EMT0100 EMR0100		
Capacity	kN	5		10		25		50		100		
Lifting Screw <sup>1</sup>	mm	16		20		30		40		55		
	Lead	Option	1	2	1	2	1	2	1	2	1	2
		mm	3	6	5	10	6	12	9	18	12	24
Gear Ratios	Option 1	5:1		5:1		6:1		6:1		8:1		
	Option 2	20:1		20:1		24:1		24:01:00		24:1		
Turn of worm for travel of lifting screw	Ratio Option 1	1 Turn	0.6mm	1.2mm	1mm	2mm	1mm	2mm	1.5mm	3mm	1.5mm	3mm
	Ratio Option 2	4 Turn	0.6mm	1.2mm	1mm	2mm	1mm	2mm	1.5mm	3mm	2mm	4mm
Max. Input Power (kW)	Gear Ratio Option 1	0.25		0.375		1.5		3.0		3.75		
	Gear Ratio Option 2	0.12		0.19		0.375		0.55		1.125		
Start up torque at full load [Nm] <sup>2</sup>	Gear Ratio Option 1	2.5	3.3	6.8	9.4	19.8	26.3	56	76	115.9	156.5	
	Gear Ratio Option 2	1.1	1.4	3	4.2	8.7	11.6	25.5	34.7	60.5	81.8	
Maximum Through Torque [Nm] <sup>7</sup>		7.5		20		59		168		347		
Lead Screw Restraining Torque [Nm] <sup>5</sup>		8	11	22	30	76	102	210	34.7	575	780	
Worm Shaft Maximum Radial Load [N] <sup>6</sup>		180		325		380		740		1000		
Maximum Input Speed (rpm)		1800		1800		1800		1800		1800		
Gear Case Material		Aluminium		Aluminium		SG Iron		SG Iron		SG Iron		
Weight (kg) - stroke = 150mm	EMT	1.3		2.36		8.45		14.9		24.3		
	EMR	1.36		2.6		8.85		16.54		28.8		
Weight (kg) per extra 25mm	EMT	0.08		0.11		0.21		0.32		0.58		
	EMR	0.03		0.05		0.11		0.19		0.36		
Gear Ratio Option 1	Gear Ratio	5:1		5:1		6:1		6:1		8:1		
	Screw Jack Static Efficiency	0.189	0.291	0.233	0.339	0.201	0.302	0.213	0.314	0.206	0.305	
	Screw Jack Dynamic Efficiency	0.252	0.370	0.306	0.424	0.264	0.383	0.281	0.398	0.272	0.388	
Gear Ratio Option 2	Gear Ratio	20:1		20:1		24:1		24:1		24:1		
	Screw Jack Static Efficiency	0.107	0.165	0.130	0.192	0.115	0.171	0.117	0.172	0.132	0.195	
	Screw Jack Dynamic Efficiency	0.160	0.235	0.194	0.268	0.167	0.242	0.172	0.244	0.190	0.271	

### Notes 1-3 of 7

1. Efficiency values for standard grease lubricated worm gear box and lifting screw.
2. For loads of 25% to 100% of screw jack capacity, torque requirements are approximately proportional to the load.
3. Efficiency values for standard grease lubricated worm gear box and lifting screw.

## E-Series - Machine Screw Jacks - Standard Performance

Model		EMT0200 EMR0200		EMT0300 EMR0300		EMT0500 EMR0500		EMT1000 EMR1000	EMT1500 EMR1500	EMT2000 EMR2000	
Capacity	kN	200		300		500		1000	1500	2000	
Lifting Screw <sup>1</sup>	mm	65		95		120		160	180	220	
	Lead	Option	1	2	1	2	1	2	1	1	1
		mm	12	24	16	32	16	32	20	20	24
Gear Ratios	Option 1	8:1		10 2/3:1		10 2/3:1		12:1	11 2/3:1	18:1	
	Option 2	24:1		32:1		32:1		36:1	N/A	N/A	
Turn of worm for travel of lifting screw	Ratio Option 1	1 Turn	1.5mm	3mm	1.5mm	3mm	1.5mm	3mm	1.67mm	1.71	1.33
	Ratio Option 2	4 Turn	2mm	4mm	2mm	4mm	2mm	4mm	6.67mm	N/A	N/A
Max. Input Power (kW)	Gear Ratio Option 1		3.75		6.0		11.25		18.5	25.3	32.5
	Gear Ratio Option 2		1.125		19		4.5		8.25	N/A	N/A
Start up torque at full load (Nm) <sup>2</sup>	Gear Ratio Option 1		263.8	343	480	618	904	1113	2025	3655	3895
	Gear Ratio Option 2		137	179	284	365	504	618	1119	N/A	N/A
Maximum Through Torque (Nm) <sup>7</sup>		396		1440		2712		6075	7310	7790	
Lead Screw Restraining Torque (Nm) <sup>5</sup>		1300	1705	5645	6975	5645	6975	14890	24610	39995	
Worm Shaft Maximum Radial Load (N) <sup>6</sup>		1600		2170		2190		2220	4450	7800	
Maximum Input Speed (rpm)		1800		1800		1800		1800	1000	600	
Gear Case Material		Steel		Steel		Steel		Steel	Steel	Steel	
Weight (kg) - stroke = 150mm	EMT	42.4		92.4		183.7		459.1	563	1172	
	EMR	49.58		113.78		224		560.4	708	1534	
Weight (kg) per extra 25mm	EMT	0.84		1.55		2.48		4.11	5.8	9	
	EMR	0.52		1.13		1.94		3.38	4.4	6.5	
Gear Ratio Option 1	Gear Ratio		8:1		10 2/3:1		10 2/3:1		12:1	11 2/3:1	18:1
	Screw Jack Static Efficiency		0.181	0.279	0.149	0.232	0.132	0.215	0.131	0.112	0.109
	Screw Jack Dynamic Efficiency		0.242	0.357	0.205	0.308	0.181	0.284	0.178	0.155	0.151
Gear Ratio Option 2	Gear Ratio		24:1		32:1		32:1		36:1	N/A	N/A
	Screw Jack Static Efficiency		0.116	0.178	0.084	0.131	0.079	0.129	0.079	N/A	N/A
	Screw Jack Dynamic Efficiency		0.169	0.250	0.128	0.192	0.120	0.188	0.123	N/A	N/A

## Notes 4-7 of 7

- All E-Series screw jacks have grease lubricated gearbox and lead screw as standard.
- Torque required to prevent the lead screw or lead nut from rotating if no anti-rotation device fitted to screw jack.
- Radial force applied midway along worm shaft key at 90° to key.
- Maximum transmittable torque through worm shaft, not through gear set.

## Upright EMT0005-U00

## Inverted EMT0005-I00

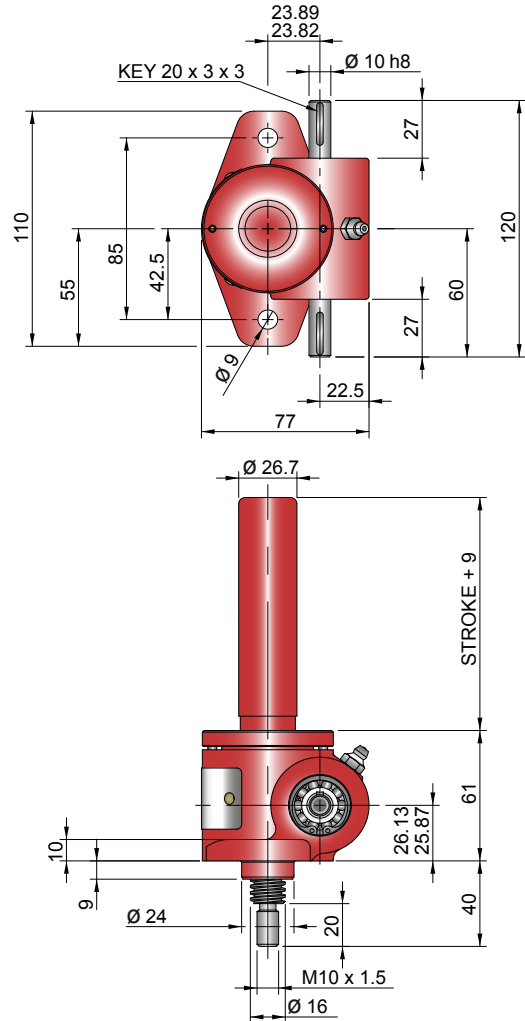
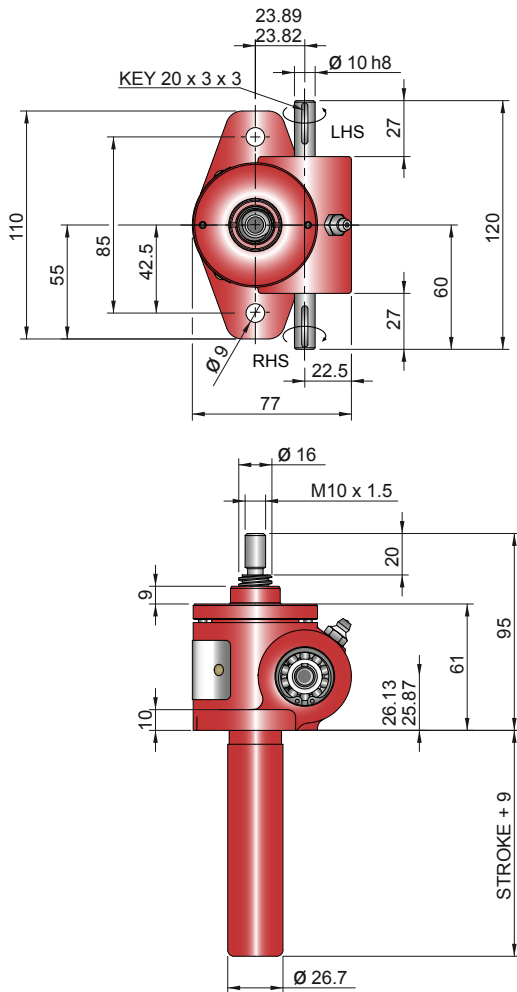

## Performance

## Closed Height

Model		EMT0005 EMR0005	
Capacity	kN	5	
Lifting Screw	Diameter (mm)	16	
	Lead	Option 1	Option 2
	mm	3	6
Gear Ratio Option 1	Gear Ratio	5:1	
	Static Efficiency	0.189	0.291
	Dynamic Efficiency	0.252	0.370
Gear Ratio Option 2	Gear Ratio	20:1	
	Static Efficiency	0.107	0.165
	Dynamic Efficiency	0.160	0.235
Max. Input power (kW)	Gear Ratio Option 1	0.25	
	Gear Ratio Option 2	0.12	
Start up torque at full load (Nm)	Gear Ratio Option 1	2.5	3.3
	Gear Ratio Option 2	1.1	1.4

Model		EMT0005 EMR0005	
Capacity	kN	5	
Lifting Screw Lead (mm)		3	6
Turn of worm for travel of lifting screw	Gear Ratio 1	1 Turn	0.6mm 1.2mm
	Gear Ratio 2	4 Turn	0.6mm 1.2mm
Maximum Through Torque (Nm)		7.5	
Lifting Screw Restraining Torque (Nm)		8	11
Worm Shaft Maximum Radial Load (N)		180	
Maximum Input Speed (rpm)		1800	
Gear Case Material		Aluminium	
Weight (kg) - stroke = 150mm	EMT	1.3	
	EMR	1.36	
Weight (kg) - per extra 25mm stroke	EMT	0.08	
	EMR	0.03	

Note: All dimension in millimetres unless otherwise stated.  
Designs subject to change without notice

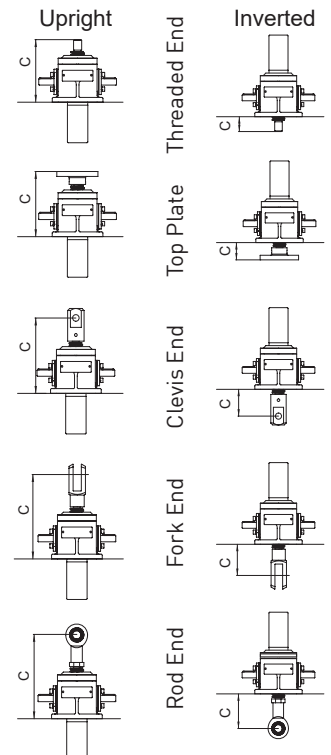

## Upright EMR0005-U00

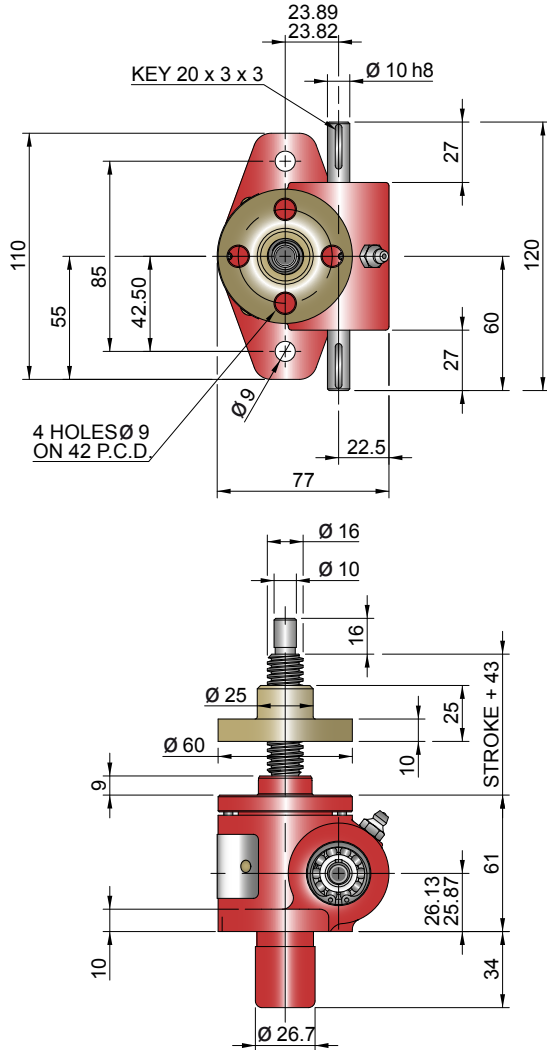

## Inverted EMR0005-I00

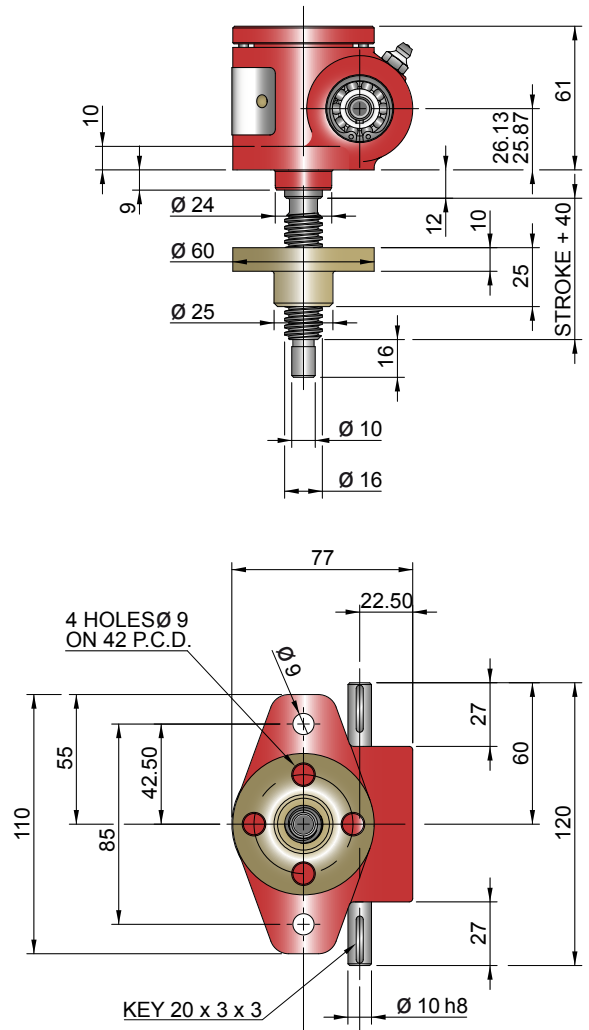

## Closed Height & Bellows Boots

Closed Height "C"	Threaded End		Top Plate		Clevis End		Fork End		Rod End	
	Upright	Inverted	Upright	Inverted	Upright	Inverted	Upright	Inverted	Upright	Inverted
EMT0005	95	40	95	40	115	60	114	59	117	62
Stroke (mm)	EMT0005 with Bellows Boots									
1-150	95	70	95	70	115	90	114	89	132	107
151-300	120	90	120	90	140	110	139	109	157	127
301-600	120	90	120	90	140	110	139	109	157	127

## Column Strength

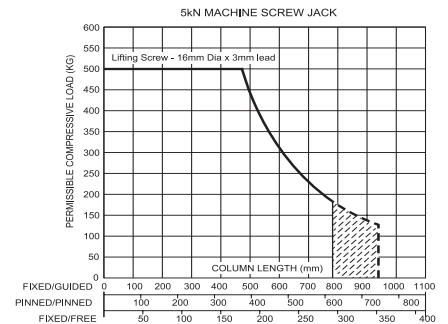

Model	A	B	D	E	G
EMT0005	25	60	13	13	100

Stroke	1-150	151-300	301-600	601-900	901-1050
EMT0005	10	20	30	-	-

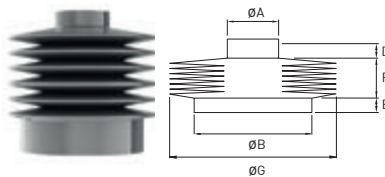

- Note:
- 1 Inverted Screw Jacks - Bellows Boot Closed Height assumes screw jack mounted on a structure with thickness = 15mm
  - 2 Inverted Screw Jacks - Recommended bellows boot mounting plate  $\text{ØB} \times [\text{E} + 5\text{mm}]$  thick.
  - 3 Inverted Screw Jacks - Screw Jack mounting plate & bellows boot mounting plate are customers own supply
  - 4 † Control tapes fitted (increase outer diameter by 20mm approximately).
  - 5 For horizontal installations with than 450 mm of stroke, internal boot guides are recommended.
  - 6 Customers with threaded end screw jacks must provide a fixing for the unattached bellows boot collar.
  - 7 Bellows boots for Rotating Screw Jacks, other sizes, stroke and materials please consult Power Jacks.

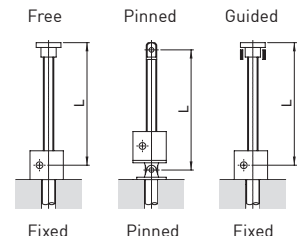

## Upright EMT0010-U00

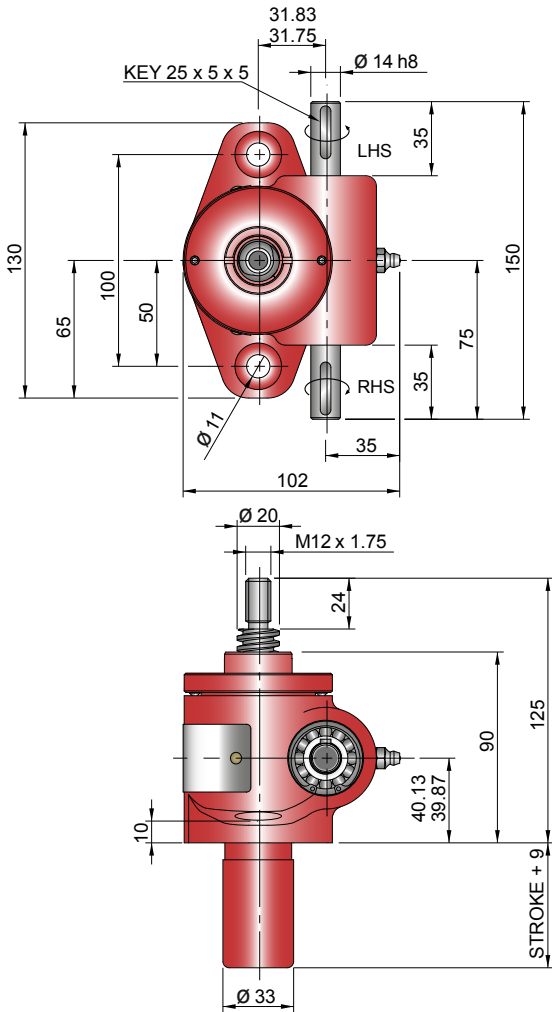

## Inverted EMT0010-I00

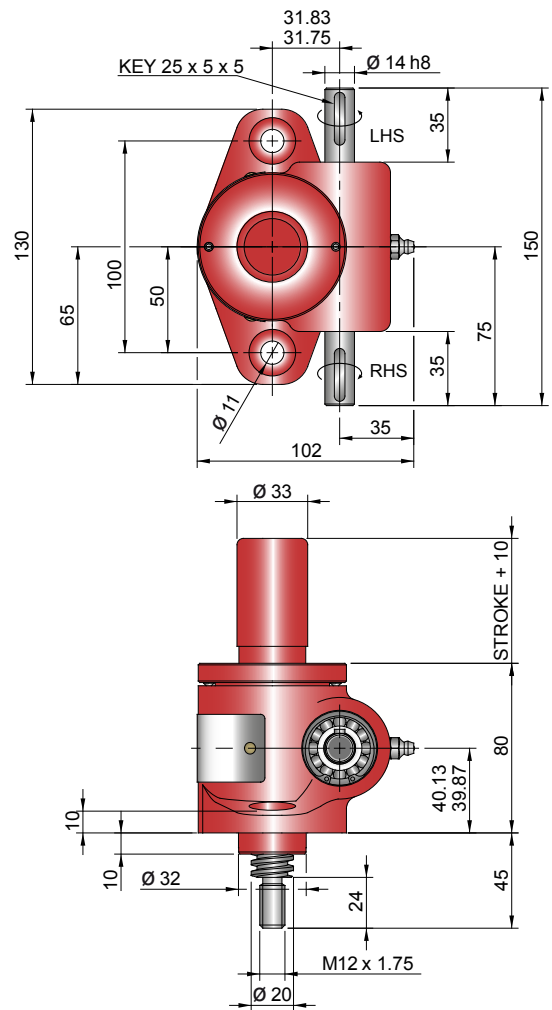

## Performance

Model		EMT0010 EMR0010	
Capacity	kN	10	
Lifting Screw	Diameter (mm)	20	
	Lead	Option	1   2
	mm	5   10	
Gear Ratio Option 1	Gear Ratio	5:1	
	Static Efficiency	0.233	0.339
	Dynamic Efficiency	0.306	0.424
Gear Ratio Option 2	Gear Ratio	20:1	
	Static Efficiency	0.130	0.192
	Dynamic Efficiency	0.194	0.268
Max. Input power (kW)	Gear Ratio Option 1	0.375	
	Gear Ratio Option 2	0.19	
Start up torque at full load (Nm)	Gear Ratio Option 1	6.8	9.4
	Gear Ratio Option 2	3	4.2

## Closed Height

Model		EMT0010 EMR0010	
Capacity	kN	10	
Lifting Screw Lead (mm)		5	10
Turn of worm for travel of lifting screw	Gear Ratio 1	1 Turn	1mm   2mm
	Gear Ratio 2	4 Turn	1mm   2mm
Maximum Through Torque (Nm)		20	
Lifting Screw Restraining Torque (Nm)		22	30
Worm Shaft Maximum Radial Load (N)		325	
Maximum Input Speed (rpm)		1800	
Gear Case Material		Aluminium	
Weight (kg) - stroke = 150mm	EMT	2.36	
	EMR	2.6	
Weight (kg) - per extra 25mm stroke	EMT	0.11	
	EMR	0.05	

Note: All dimension in millimetres unless otherwise stated.  
Designs subject to change without notice

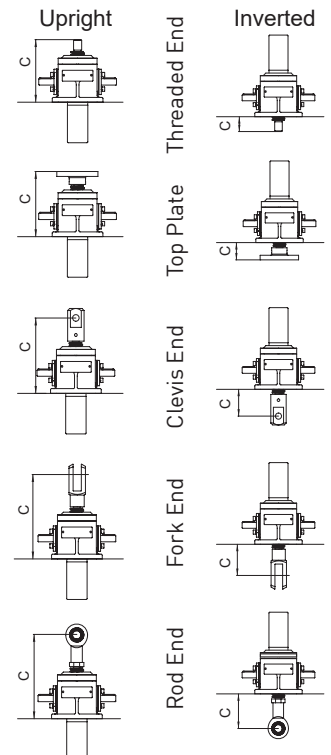

## Upright EMR0010-U00

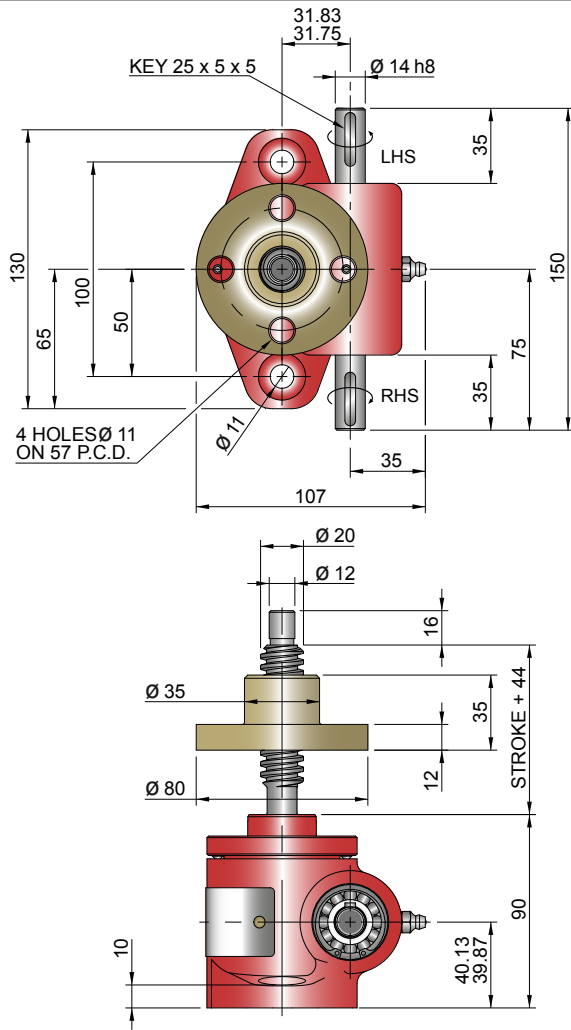

## Inverted EMR0010-I00

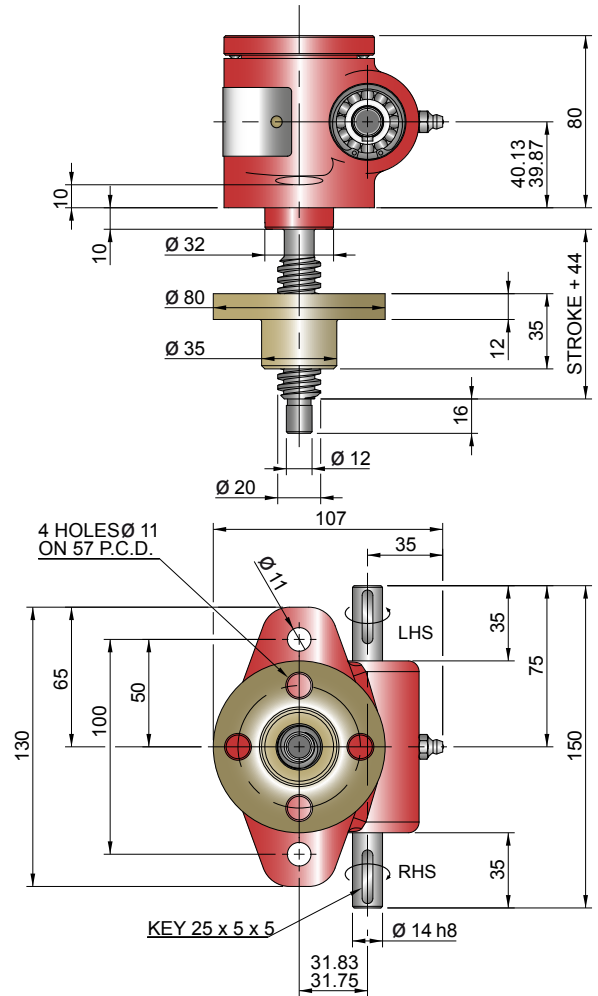

## Closed Height & Bellows Boots

Closed Height "C"	Threaded End		Top Plate		Clevis End		Fork End		Rod End	
	Upright	Inverted	Upright	Inverted	Upright	Inverted	Upright	Inverted	Upright	Inverted
EMT0010	125	45	125	45	145	65	148	98	150	70
Stroke (mm)	EMT0010 with Bellows Boots									
0-150	125	75	125	75	145	95	148	98	165	115
151-300	130	95	130	95	150	115	153	118	170	135
301-600	140	95	140	95	160	115	163	118	180	135
751-1000	-	-	-	-	-	-	-	-	-	-

Model	A	B	D	E	G
EMT0010	30	70	15	15	110

Stroke	1-150	151-300	301-600	601-900	901-1050
EMT0010	8	20	35	-	-

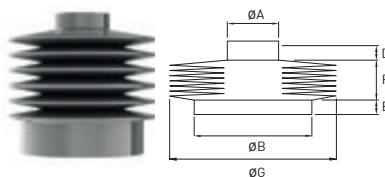

## Column Strength

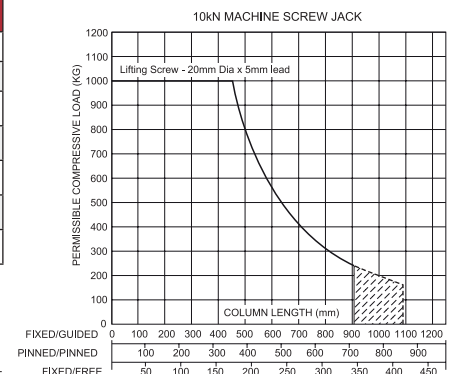

Note:

- 1 Inverted Screw Jacks - Bellows Boot Closed Height assumes screw jack mounted on a structure with thickness = 15mm
- 2 Inverted Screw Jacks - Recommended bellows boot mounting plate  $\varnothing B \times [E + 5\text{mm}]$  thick.
- 3 Inverted Screw Jacks - Screw Jack mounting plate & bellows boot mounting plate are customers own supply
- 4 † Control tapes fitted (increase outer diameter by 20mm approximately).
- 5 For horizontal installations with than 450 mm of stroke, internal boot guides are recommended.
- 6 Customers with threaded end screw jacks must provide a fixing for the unattached bellows boot collar.
- 7 Bellows boots for Rotating Screw Jacks, other sizes, stroke and materials please consult Power Jacks.

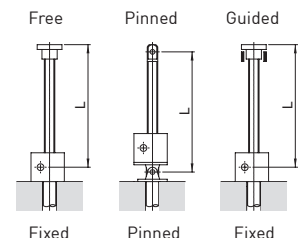

## Upright EMT0025-U00

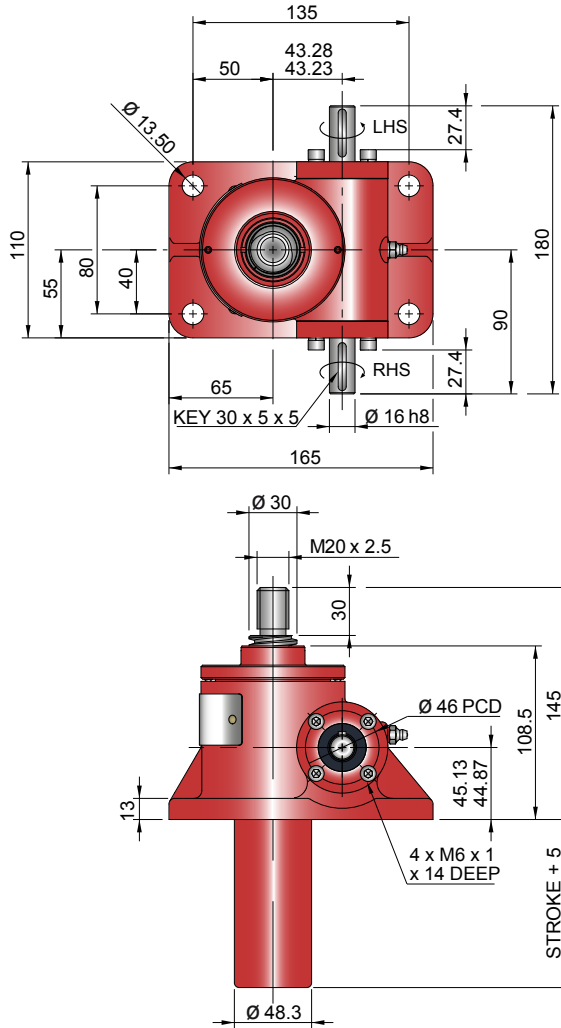

## Inverted EMT0025-I00

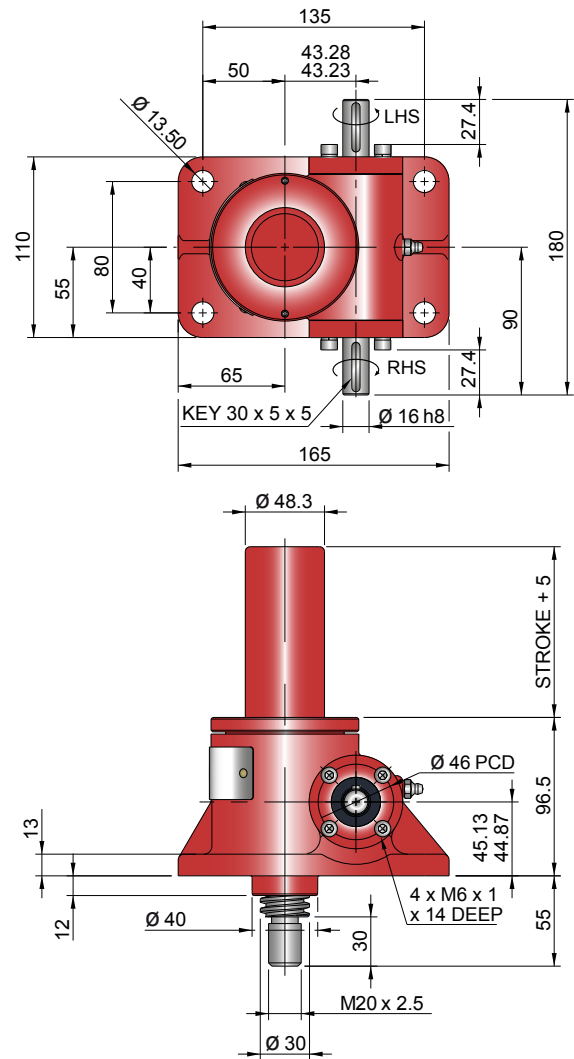

## Performance

## Closed Height

Model		EMT0025 EMR0025	
Capacity	kN	25	
Lifting Screw	Diameter (mm)	30	
	Lead	Option	1   2
	mm	6   12	
Gear Ratio Option 1	Gear Ratio	6:1	
	Static Efficiency	0.201	0.302
	Dynamic Efficiency	0.264	0.383
Gear Ratio Option 2	Gear Ratio	24:1	
	Static Efficiency	0.115	0.171
	Dynamic Efficiency	0.167	0.242
Max. Input power (kW)	Gear Ratio Option 1	1.5	
	Gear Ratio Option 2	0.375	
Start up torque at full load (Nm)	Gear Ratio Option 1	19.8	26.3
	Gear Ratio Option 2	8.7	11.6

Model		EMT0025 EMR0025	
Capacity	kN	25	
Lifting Screw Lead (mm)		6	12
Turn of worm for travel of lifting screw	Gear Ratio 1	1 Turn	1mm   2mm
	Gear Ratio 2	4 Turn	1mm   2mm
Maximum Through Torque (Nm)		59	
Lifting Screw Restraining Torque (Nm)		76	102
Worm Shaft Maximum Radial Load (N)		380	
Maximum Input Speed (rpm)		1800	
Gear Case Material		Aluminium	
Weight (kg) - stroke = 150mm	EMT	8.45	
	EMR	8.85	
Weight (kg) - per extra 25mm stroke	EMT	0.21	
	EMR	0.11	

Note: All dimension in millimetres unless otherwise stated.  
Designs subject to change without notice

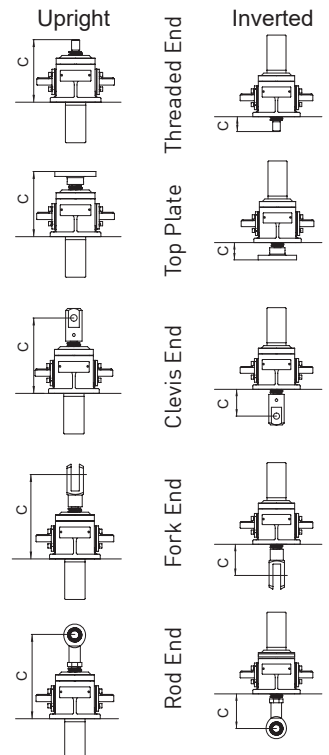



## Upright EMR0025-U00

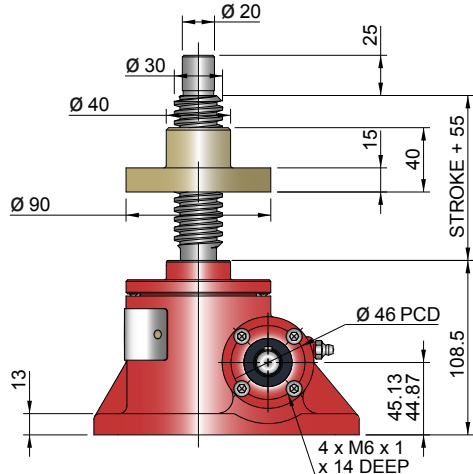
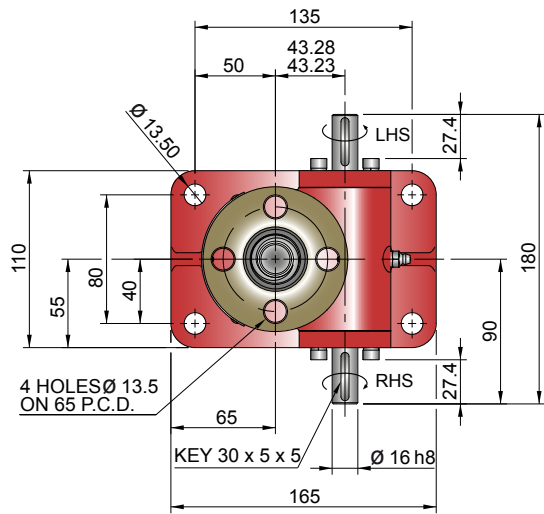

## Inverted EMR0025-I00

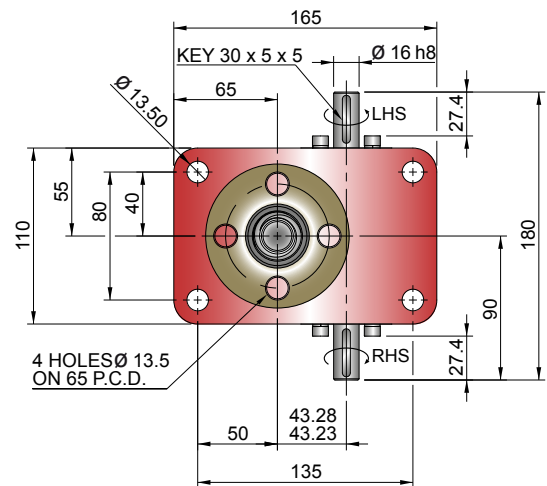
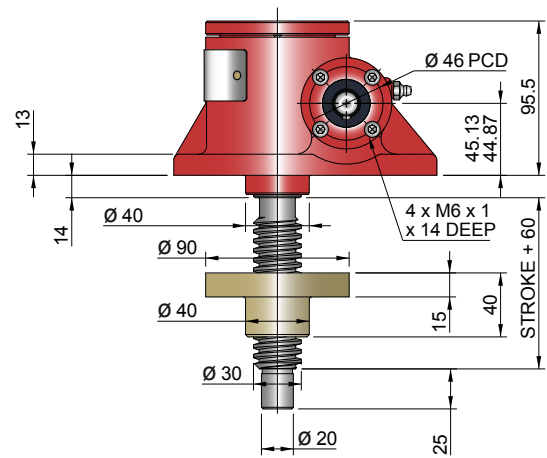

## Closed Height & Bellows Boots

Closed Height "C"	Threaded End		Top Plate		Clevis End		Fork End		Rod End	
	Upright	Inverted	Upright	Inverted	Upright	Inverted	Upright	Inverted	Upright	Inverted
EMT0025	145	55	145	55	170	80	194	104	190	100
Stroke (mm)	EMT0025 with Bellows Boots									
1-300	145	80	145	80	170	105	194	129	205	140
301-600	145	80	145	80	170	105	194	129	205	140
601-1050	170	105	170	105	195	130	219	154	230	165
1051-1500	195	130	195	130	220	155	244	179	255	190

Model	A	B	D	E	G
EMT0025	40	90	15	23	120

Stroke	1-150	151-301	301-600	601-1050	1051-1500
EMT0025	8	20	30	50	70

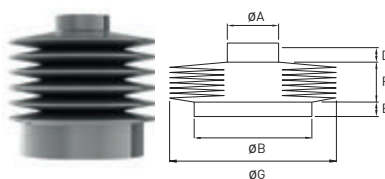

## Column Strength

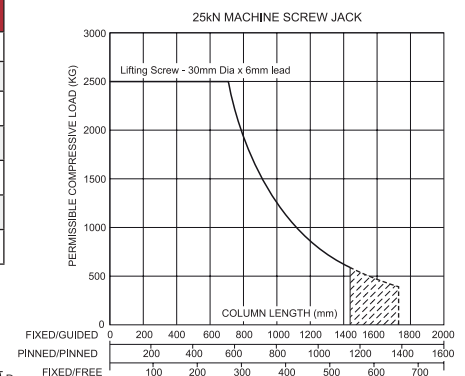

Note:

- Inverted Screw Jacks - Bellows Boot Closed Height assumes screw jack mounted on a structure with thickness = 15mm
- Inverted Screw Jacks - Recommended bellows boot mounting plate ØB x [E +5mm] thick.
- Inverted Screw Jacks - Screw Jack mounting plate & bellows boot mounting plate are customers own supply
- † Control tapes fitted (increase outer diameter by 20mm approximately).
- For horizontal installations with than 450 mm of stroke, internal boot guides are recommended.
- Customers with threaded end screw jacks must provide a fixing for the unattached bellows boot collar.
- Bellows boots for Rotating Screw Jacks, other sizes, stroke and materials please consult Power Jacks.

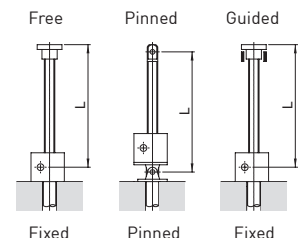

## Upright EMT0050-U00

## Inverted EMT0050-I00

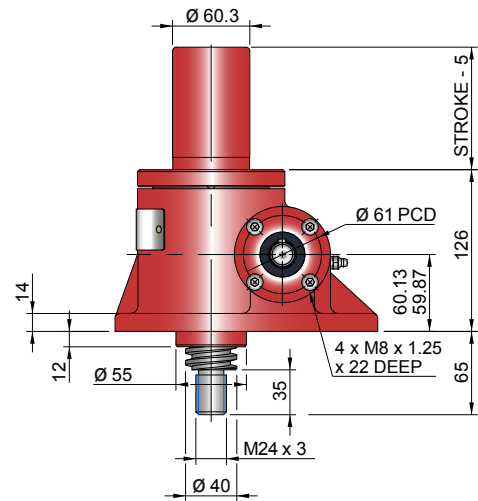
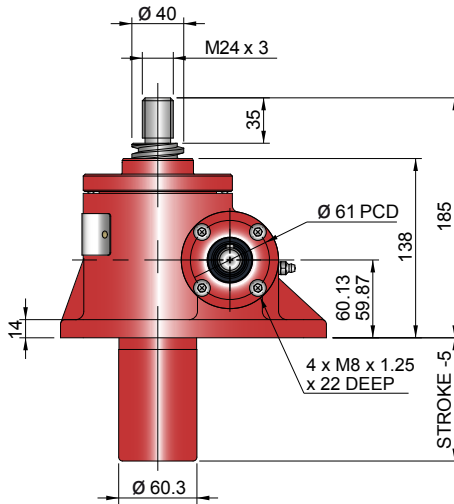
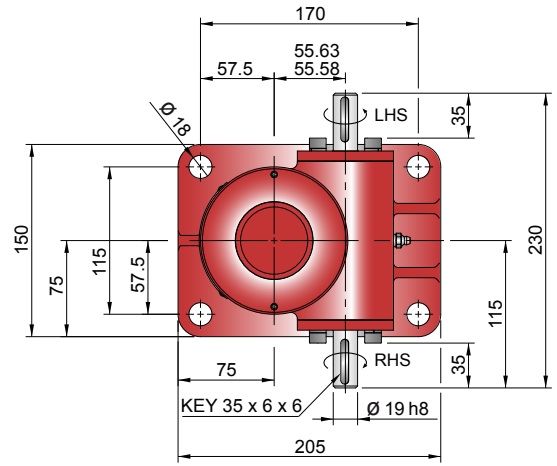
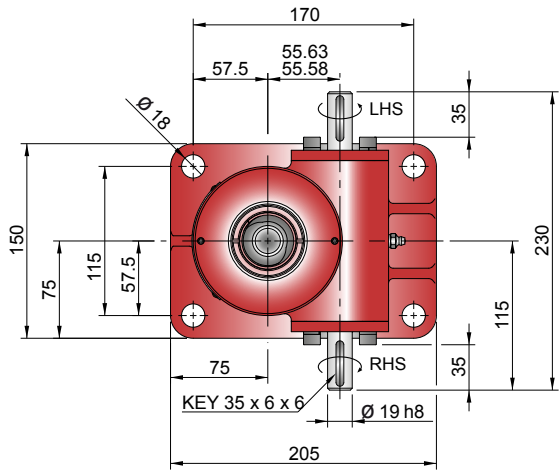

## Performance

## Closed Height

Model		EMT0050 EMR0050	
Capacity	kN	50	
Lifting Screw	Diameter (mm)	40	
	Lead	Option	1   2
	mm	9	18
Gear Ratio Option 1	Gear Ratio	6:1	
	Static Efficiency	0.213	0.314
	Dynamic Efficiency	0.281	0.398
Gear Ratio Option 2	Gear Ratio	24:1	
	Static Efficiency	0.117	0.172
	Dynamic Efficiency	0.172	0.244
Max. Input power (kW)	Gear Ratio Option 1	3.0	
	Gear Ratio Option 2	0.55	
Start up torque at full load (Nm)	Gear Ratio Option 1	56	76
	Gear Ratio Option 2	25.5	34.7

Model		EMT0050 EMR0050	
Capacity	kN	50	
Lifting Screw (mm)		9	18
Turn of worm for travel of lifting screw	Gear Ratio 1	1 Turn	1.5mm   3mm
	Gear Ratio 2	4 Turn	1.5mm   3mm
Maximum Through Torque (Nm)		168	
Lifting Screw Restraining Torque (Nm)		210	290
Worm Shaft Maximum Radial Load (N)		740	
Maximum Input Speed (rpm)		1800	
Gear Case Material		SG Iron	
Weight (kg) - stroke = 150mm	EMT	14.9	
	EMR	16.54	
Weight (kg) - per extra 25mm stroke	EMT	0.32	
	EMR	0.19	

Note: All dimension in millimetres unless otherwise stated.  
Designs subject to change without notice

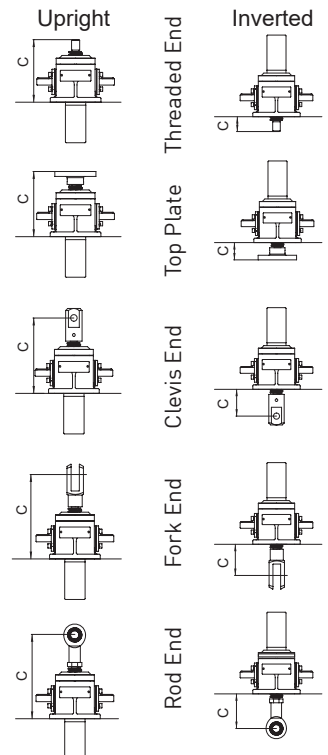

## Upright EMR0050-U00

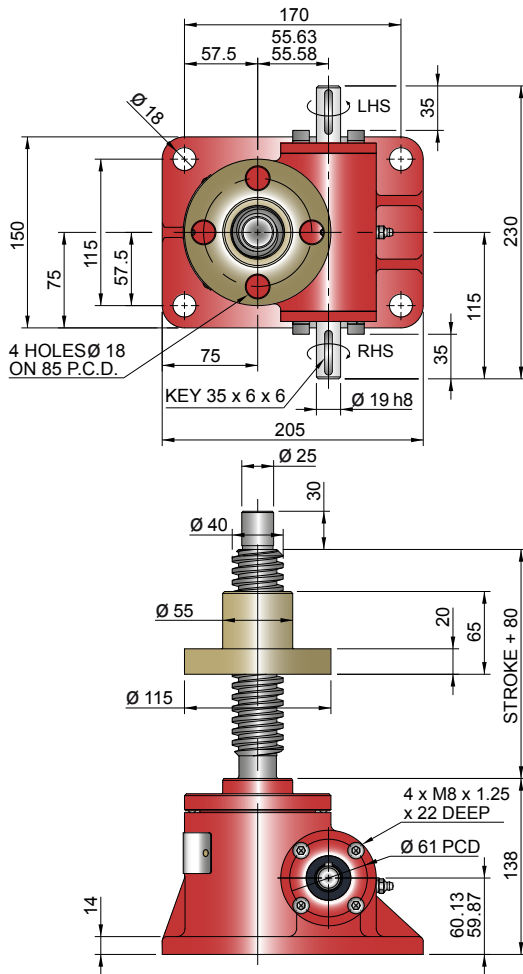

## Inverted EMR0050-I00

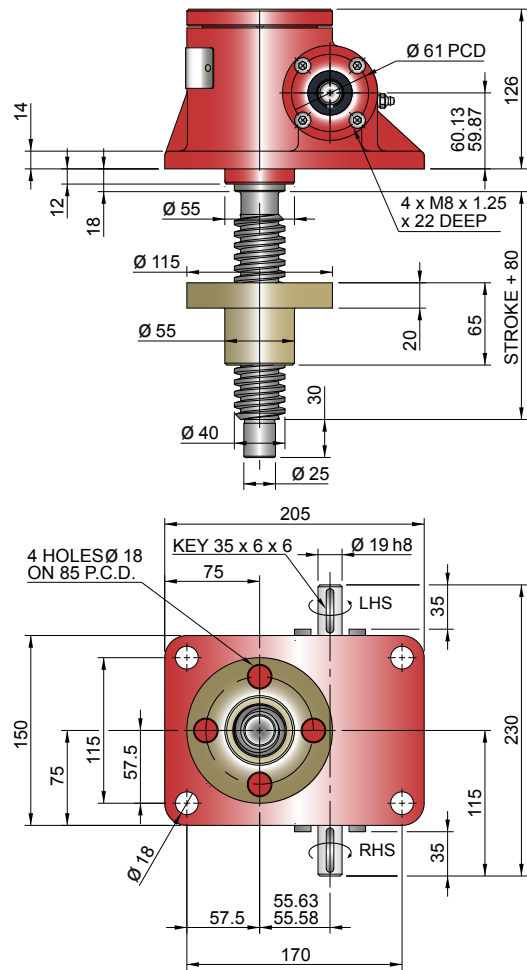

## Closed Height & Bellows Boots

Closed Height "C"	Threaded End		Top Plate		Clevis End		Fork End		Rod End	
	Upright	Inverted	Upright	Inverted	Upright	Inverted	Upright	Inverted	Upright	Inverted
EMT0050	185	65	185	65	210	90	248	128	242	122
Stroke (mm)	EMT0050 with Bellows Boots									
1-150	185	110	185	110	210	135	248	173	257	182
151-300	185	120	185	120	210	145	248	183	257	192
301-600	210	130	210	130	235	155	273	193	282	202
601-1050	210	150	210	150	235	175	273	213	282	222
1051-1500	235	170	235	170	260	195	298	233	307	242

Model	A	B	D	E	G
EMT0050	50	115	15	31	140

Stroke	1-150	151-300	301-600	601-1050	1051-1500
EMT0050	8	20	30	50	70

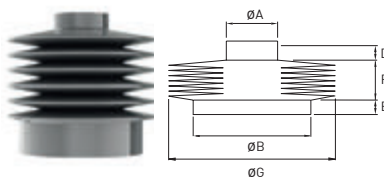

## Column Strength

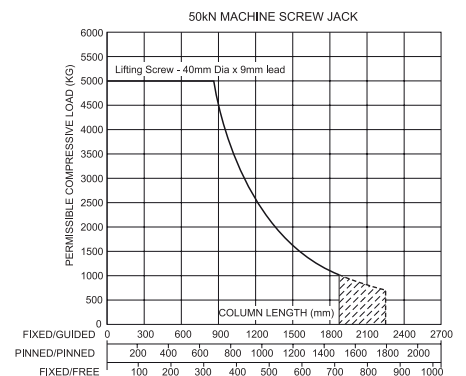

Note:

- 1 Inverted Screw Jacks - Bellows Boot Closed Height assumes screw jack mounted on a structure with thickness = 15mm
- 2 Inverted Screw Jacks - Recommended bellows boot mounting plate  $\varnothing B \times [E + 5\text{mm}]$  thick.
- 3 Inverted Screw Jacks - Screw Jack mounting plate & bellows boot mounting plate are customers own supply
- 4 † Control tapes fitted (increase outer diameter by 20mm approximately).
- 5 For horizontal installations with than 450 mm of stroke, internal boot guides are recommended.
- 6 Customers with threaded end screw jacks must provide a fixing for the unattached bellows boot collar.
- 7 Bellows boots for Rotating Screw Jacks, other sizes, stroke and materials please consult Power Jacks.

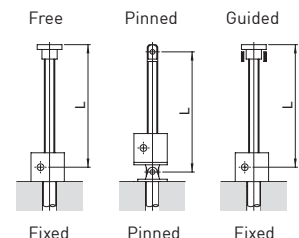

## Upright EMT0100-U00

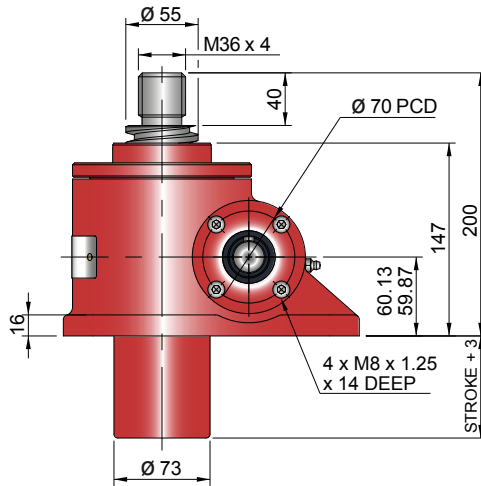
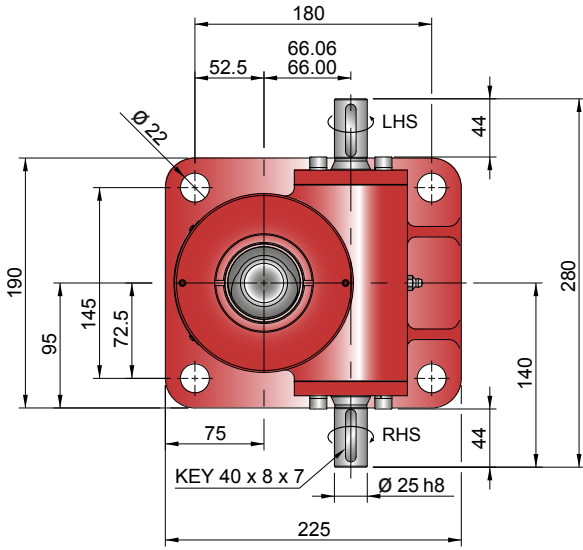

## Inverted EMT0100-I00

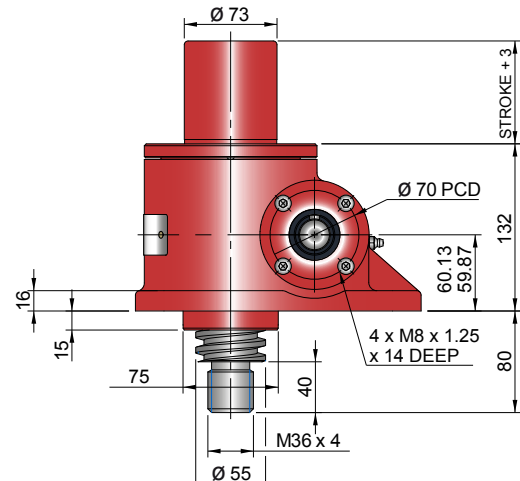
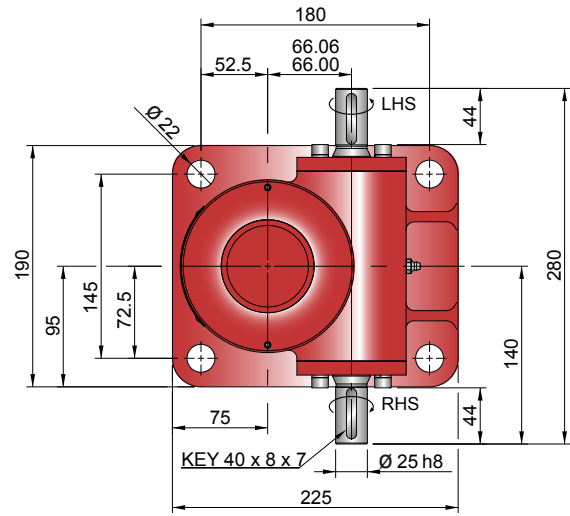

## Performance

## Closed Height

Model		EMT0100 EMR0100	
Capacity	kN	100	
Lifting Screw	Diameter (mm)	55	
	Lead	Option 1	Option 2
	mm	12	24
Gear Ratio Option 1	Gear Ratio	8:1	
	Static Efficiency	0.206	0.305
	Dynamic Efficiency	0.272	0.388
Gear Ratio Option 2	Gear Ratio	24:1	
	Static Efficiency	0.132	0.195
	Dynamic Efficiency	0.190	0.271
Max. Input power (kW)	Gear Ratio Option 1	3.75	
	Gear Ratio Option 2	1.125	
Start up torque at full load (Nm)	Gear Ratio Option 1	115.9	156.5
	Gear Ratio Option 2	60.5	81.8

Model		EMT0100 EMR0100		
Capacity	kN	100		
Lifting Screw (mm)		12	24	
Turn of worm for travel of lifting screw	Gear Ratio 1	1 Turn	1.5mm	3mm
	Gear Ratio 2	4 Turn	2mm	4mm
Maximum Through Torque (Nm)		347		
Lifting Screw Restraining Torque (Nm)		575	780	
Worm Shaft Maximum Radial Load (N)		1000		
Maximum Input Speed (rpm)		1800		
Gear Case Material		SG Iron		
Weight (kg) - stroke = 150mm	EMT	24.3		
	EMR	28.8		
Weight (kg) - per extra 25mm stroke	EMT	0.58		
	EMR	0.36		

Note: All dimension in millimetres unless otherwise stated.  
Designs subject to change without notice

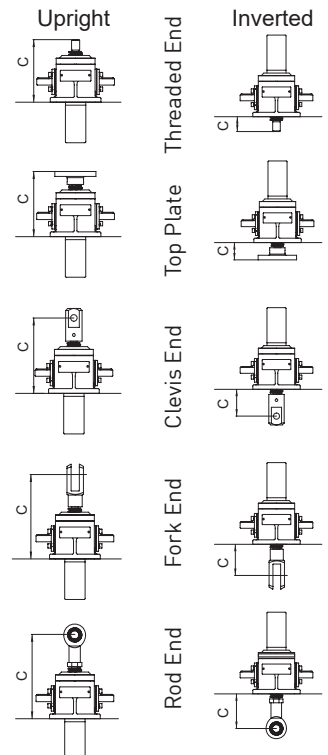

## Upright EMR0100-U00

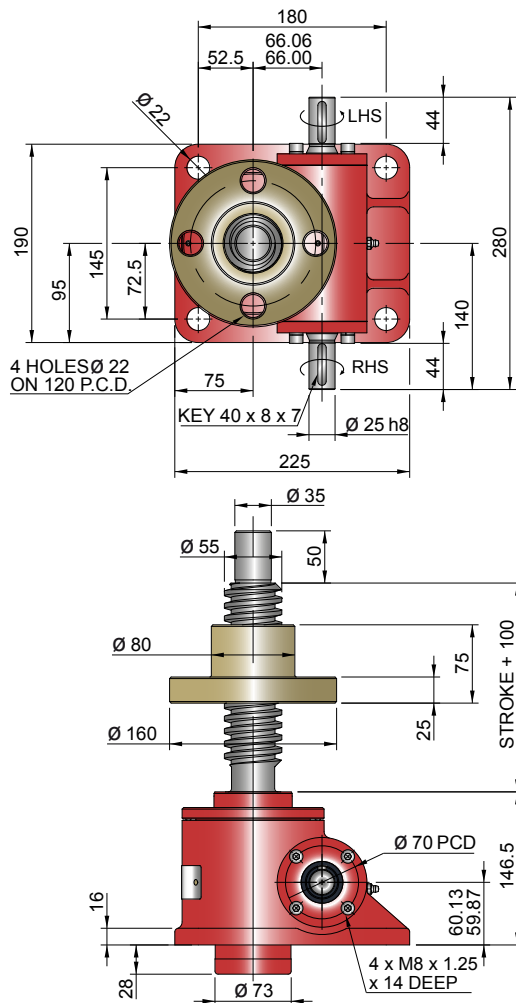

## Inverted EMR0100-I00

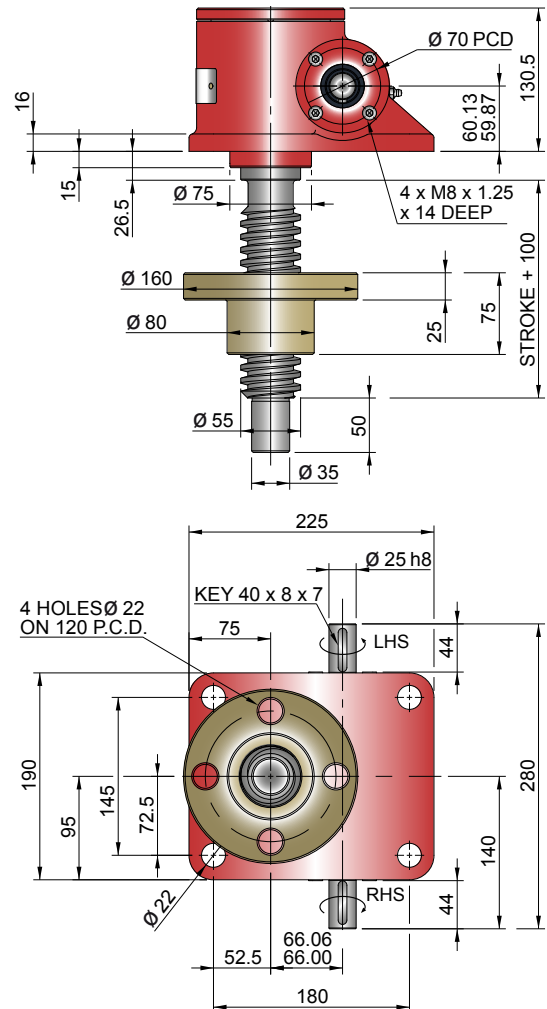

## Closed Height & Bellows Boots

Closed Height "C"	Threaded End		Top Plate		Clevis End		Fork End		Rod End	
	Upright	Inverted	Upright	Inverted	Upright	Inverted	Upright	Inverted	Upright	Inverted
EMT0100	200	80	200	80	245	125	302	182	283	163
Stroke (mm)	EMT0100 with Bellows Boots									
1-300	200	105	200	105	245	150	302	207	298	203
301-600	200	130	200	130	245	175	302	232	298	228
601-1050	225	130	225	130	270	175	327	232	323	228
1051-1500	250	155	250	155	295	200	352	257	348	253

Model	A	B	D	E	G
EMT0100	65	136	15	31	150

Stroke	1-300	301-600	601-1050	1051-1500
EMT0100	20	30	50	70

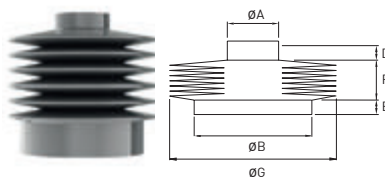

## Column Strength

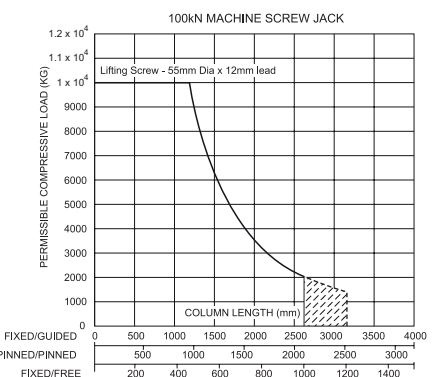

Note:

- 1 Inverted Screw Jacks - Bellows Boot Closed Height assumes screw jack mounted on a structure with thickness = 15mm
- 2 Inverted Screw Jacks - Recommended bellows boot mounting plate  $\varnothing B \times [E + 5\text{mm}]$  thick.
- 3 Inverted Screw Jacks - Screw Jack mounting plate & bellows boot mounting plate are customers own supply
- 4 † Control tapes fitted (increase outer diameter by 20mm approximately).
- 5 For horizontal installations with than 450 mm of stroke, internal boot guides are recommended.
- 6 Customers with threaded end screw jacks must provide a fixing for the unattached bellows boot collar.
- 7 Bellows boots for Rotating Screw Jacks, other sizes, stroke and materials please consult Power Jacks.

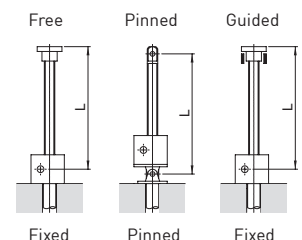

## Upright EMT0200-U00

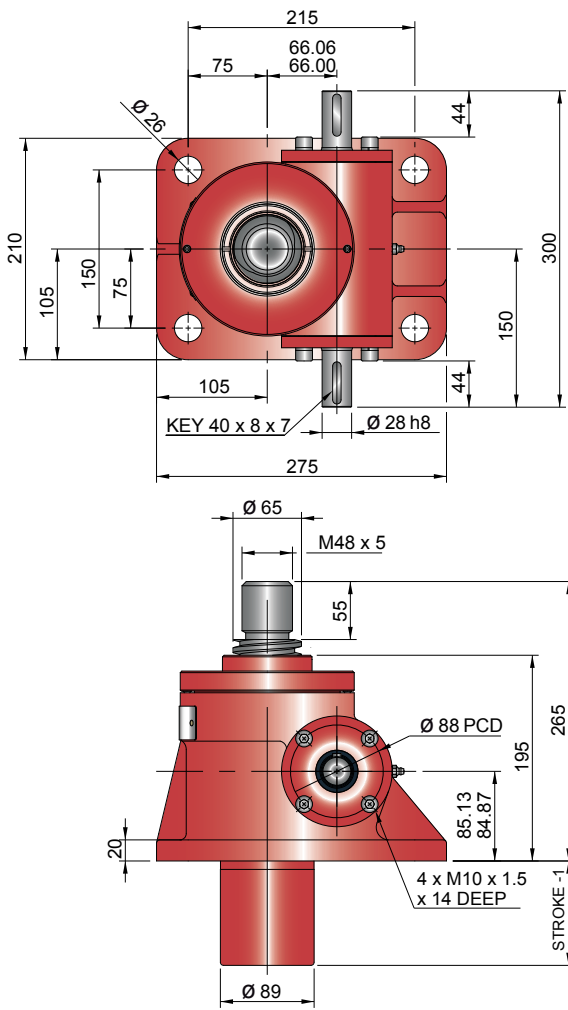

## Inverted EMT0200-I00

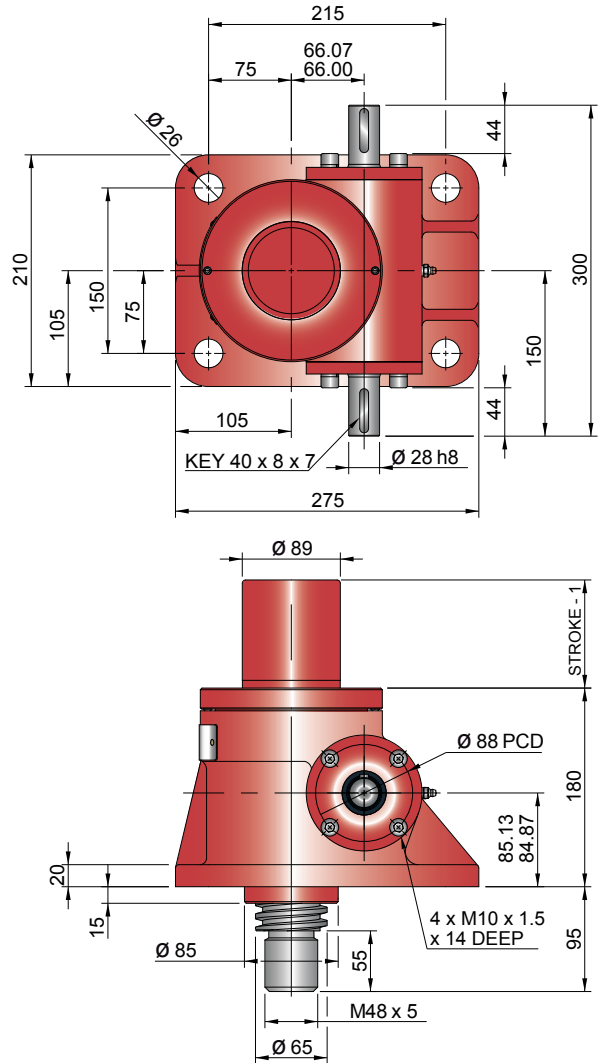

## Performance

Model		EMT0200 EMR0200	
Capacity	kN	200	
Lifting Screw	Diameter (mm)	65	
	Lead	Option 1	Option 2
	mm	12	24
Gear Ratio Option 1	Gear Ratio	8:1	
	Static Efficiency	0.181	0.279
	Dynamic Efficiency	0.242	0.357
Gear Ratio Option 2	Gear Ratio	24:1	
	Static Efficiency	0.116	0.178
	Dynamic Efficiency	0.169	0.250
Max. Input power (kW)	Gear Ratio Option 1	3.75	
	Gear Ratio Option 2	1.125	
Start up torque at full load (Nm)	Gear Ratio Option 1	263.8	343
	Gear Ratio Option 2	137	179

## Closed Height

Model		EMT0200 EMR0200		
Capacity	kN	200		
Lifting Screw (mm)		12	24	
Turn of worm for travel of lifting screw	Gear Ratio 1	1 Turn	1.5mm	3mm
	Gear Ratio 2	4 Turn	2mm	4mm
Maximum Through Torque (Nm)		396		
Lifting Screw Restraining Torque (Nm)		1300	1705	
Worm Shaft Maximum Radial Load (N)		1600		
Maximum Input Speed (rpm)		1800		
Gear Case Material		Steel		
Weight (kg) - stroke = 150mm	EMT	42.4		
	EMR	49.58		
Weight (kg) - per extra 25mm stroke	EMT	0.84		
	EMR	0.52		

Note: All dimension in millimetres unless otherwise stated.  
Designs subject to change without notice

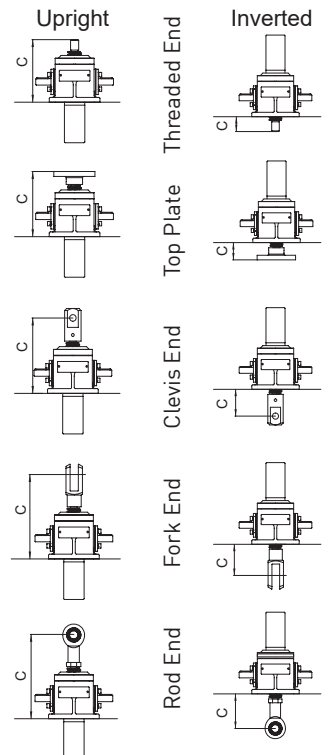



## Upright EMR0200-U00

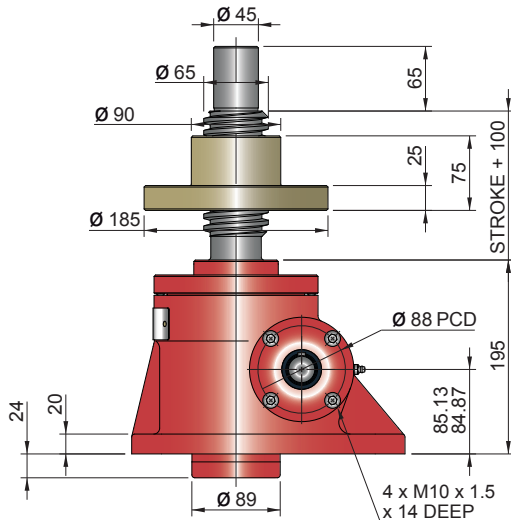
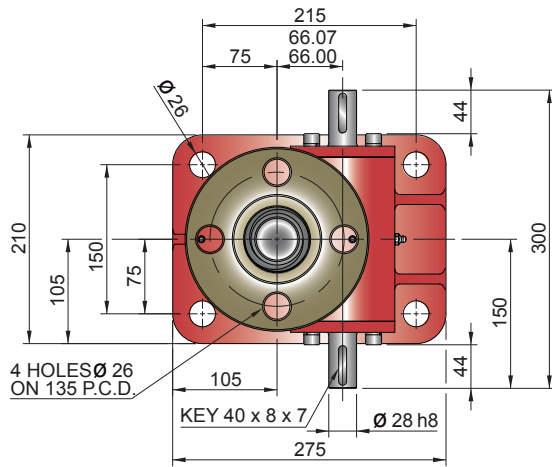

## Inverted EMR0200-I00

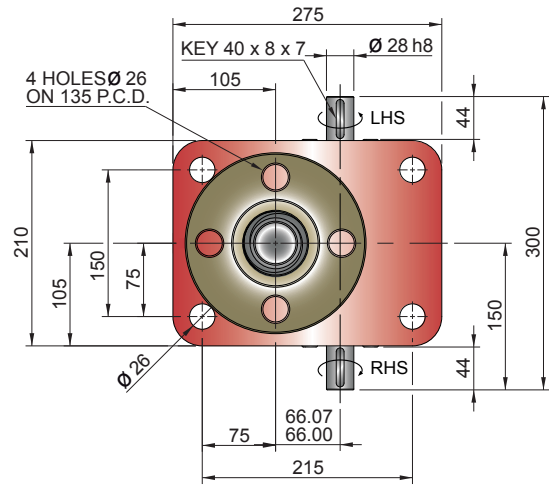
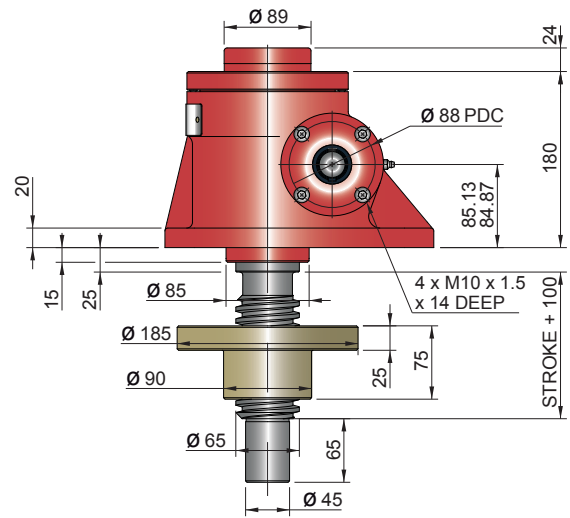

## Closed Height & Bellows Boots

Closed Height "C"	Threaded End		Top Plate		Clevis End		Fork End		Rod End	
	Upright	Inverted	Upright	Inverted	Upright	Inverted	Upright	Inverted	Upright	Inverted
EMT0200	265	95	265	95	310	140	400	230	367	197
Stroke (mm)	EMT0200 with Bellows Boots									
1-300	265	120	265	120	310	165	400	255	387	242
301-600	265	145	265	145	310	190	400	280	387	267
601-1050	290	145	290	145	335	190	425	280	412	267
1051-1500	315	170	315	170	360	215	450	305	437	292

Model	A	B	D	E	G
EMT0200	75	165	20	20	165

Stroke	1-300	301-600	601-1050	1051-1500
EMT0200	20	30	50	70

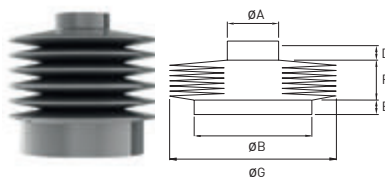

## Column Strength

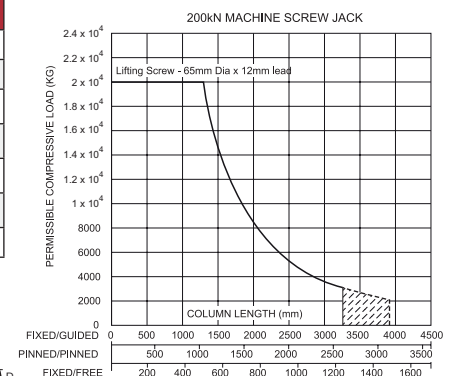

### Note:

- 1 Inverted Screw Jacks - Bellows Boot Closed Height assumes screw jack mounted on a structure with thickness = 15mm
- 2 Inverted Screw Jacks - Recommended bellows boot mounting plate  $\varnothing B \times [E + 5mm]$  thick.
- 3 Inverted Screw Jacks - Screw Jack mounting plate & bellows boot mounting plate are customers own supply
- 4 † Control tapes fitted (increase outer diameter by 20mm approximately).
- 5 For horizontal installations with than 450 mm of stroke, internal boot guides are recommended.
- 6 Customers with threaded end screw jacks must provide a fixing for the unattached bellows boot collar.
- 7 Bellows boots for Rotating Screw Jacks, other sizes, stroke and materials please consult Power Jacks.

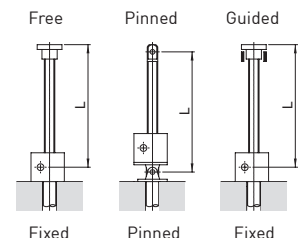

## Upright EMT0300-U00

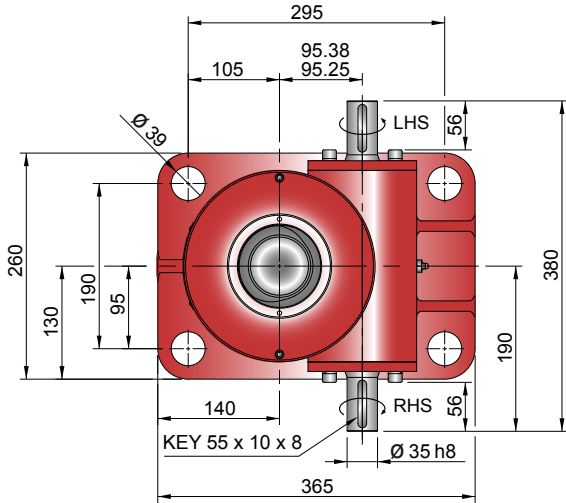

## Inverted EMT0300-I00

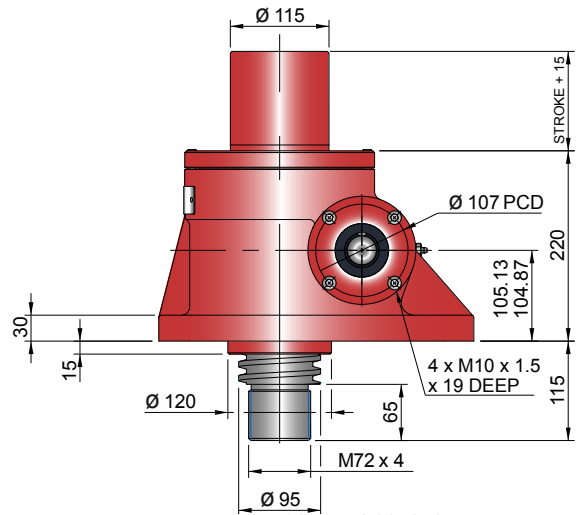
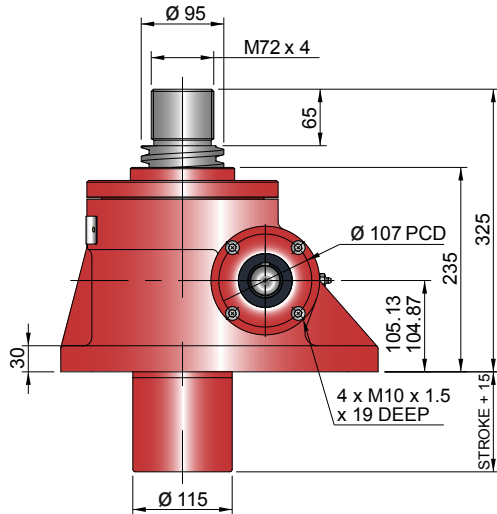
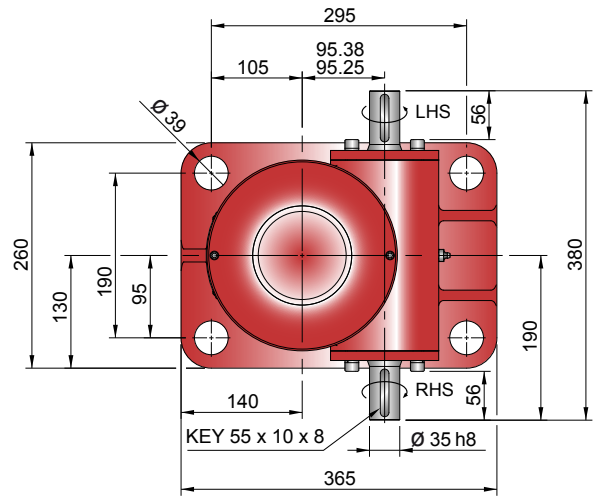

## Performance

## Closed Height

Model		EMT0300 EMR0300	
Capacity	kN	300	
Lifting Screw	Diameter (mm)	95	
	Lead	Option 1	Option 2
	mm	16	32
Gear Ratio Option 1	Gear Ratio	10 2/3:1	
	Static Efficiency	0.149	0.232
	Dynamic Efficiency	0.205	0.308
Gear Ratio Option 2	Gear Ratio	32:1	
	Static Efficiency	0.084	0.131
	Dynamic Efficiency	0.128	0.192
Max. Input power (kW)	Gear Ratio Option 1	6.0	
	Gear Ratio Option 2	1.9	
Start up torque at full load (Nm)	Gear Ratio Option 1	480	618
	Gear Ratio Option 2	284	365

Model		EMT0300 EMR0300		
Capacity	kN	300		
Lifting Screw (mm)		16	32	
Turn of worm for travel of lifting screw	Gear Ratio 1	1 Turn	1.5mm	3mm
	Gear Ratio 2	4 Turn	2mm	4mm
Maximum Through Torque (Nm)		1440		
Lifting Screw Restraining Torque (Nm)		2805	3610	
Worm Shaft Maximum Radial Load (N)		2170		
Maximum Input Speed (rpm)		1800		
Gear Case Material		Steel		
Weight (kg) - stroke = 150mm	EMT	92.4		
	EMR	113.78		
Weight (kg) - per extra 25mm stroke	EMT	1.55		
	EMR	1.13		

Note: All dimension in millimetres unless otherwise stated.  
Designs subject to change without notice

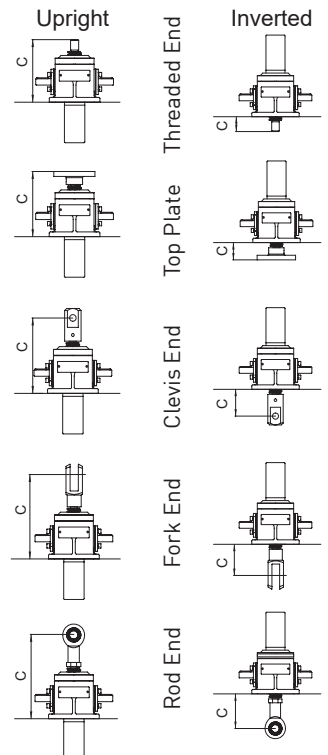

## Upright EMR0300-U00

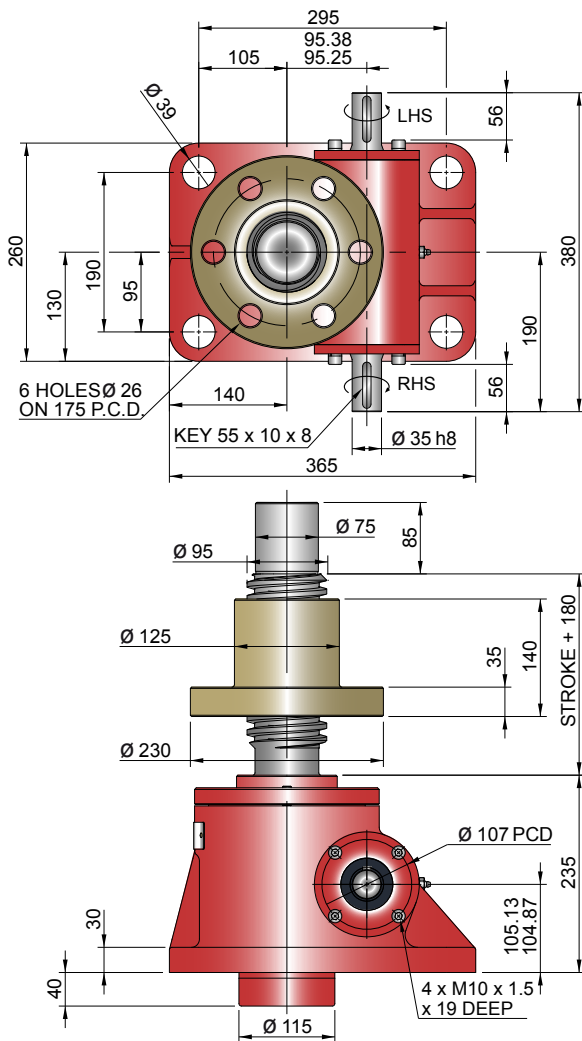

## Inverted EMR0300-I00

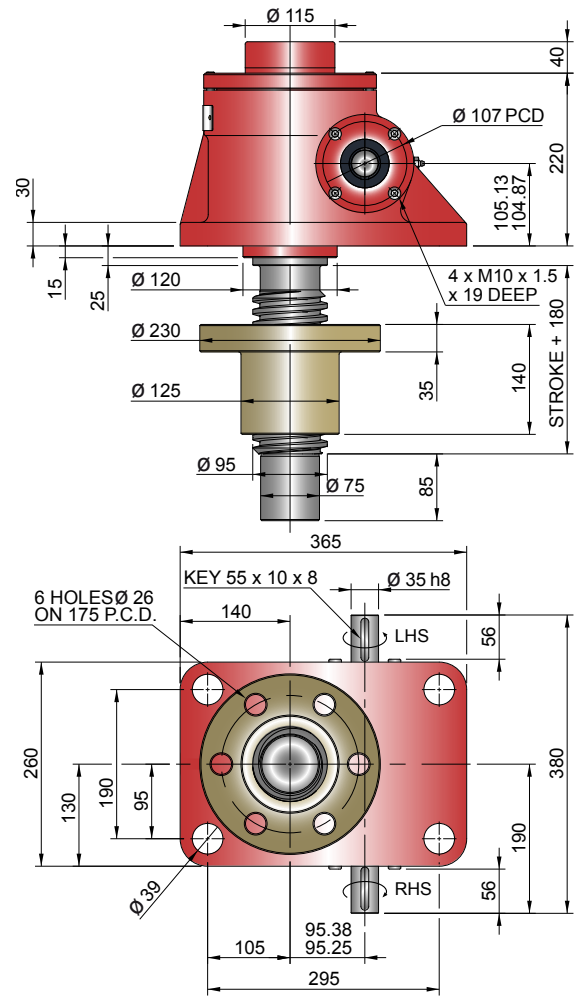

## Closed Height & Bellows Boots

Closed Height "C"	Threaded End		Top Plate		Clevis End		Fork End		Rod End	
	Upright	Inverted	Upright	Inverted	Upright	Inverted	Upright	Inverted	Upright	Inverted
EMT0300	325	115	325	115	365	155	on request		on request	
Stroke (mm)	EMT0300 with Bellows Boots									
1-300	325	140	325	140	365	180	-	-	-	-
301-600	325	165	325	165	365	205	-	-	-	-
601-1050	350	165	350	165	390	205	-	-	-	-
1051-1500	375	190	375	190	415	230	-	-	-	-

Model	A	B	D	E	G
EMT0300	110	220	20	20	191

Stroke	1-300	301-600	601-1050	1051-1500
EMT0300	20	30	50	70

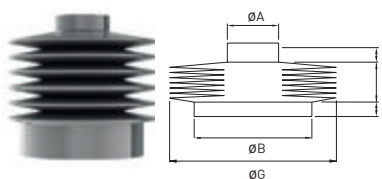

## Column Strength

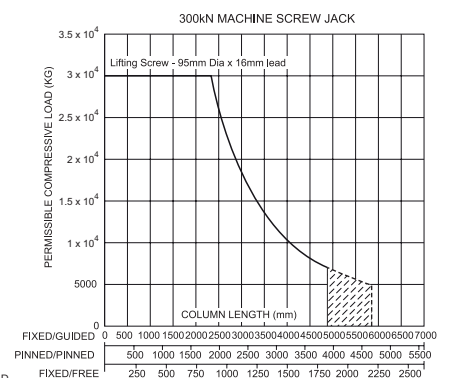

### Note:

- 1 Inverted Screw Jacks - Bellows Boot Closed Height assumes screw jack mounted on a structure with thickness = 15mm
- 2 Inverted Screw Jacks - Recommended bellows boot mounting plate  $\varnothing B \times [E + 5mm]$  thick.
- 3 Inverted Screw Jacks - Screw Jack mounting plate & bellows boot mounting plate are customers own supply
- 4 † Control tapes fitted (increase outer diameter by 20mm approximately).
- 5 For horizontal installations with than 450 mm of stroke, internal boot guides are recommended.
- 6 Customers with threaded end screw jacks must provide a fixing for the unattached bellows boot collar.
- 7 Bellows boots for Rotating Screw Jacks, other sizes, stroke and materials please consult Power Jacks.

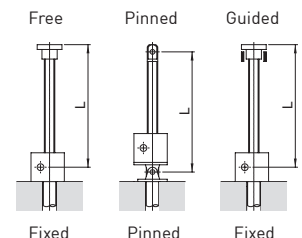

## Upright EMT0500-U00

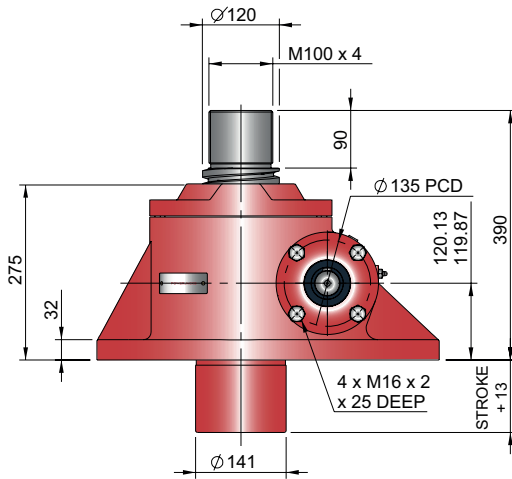
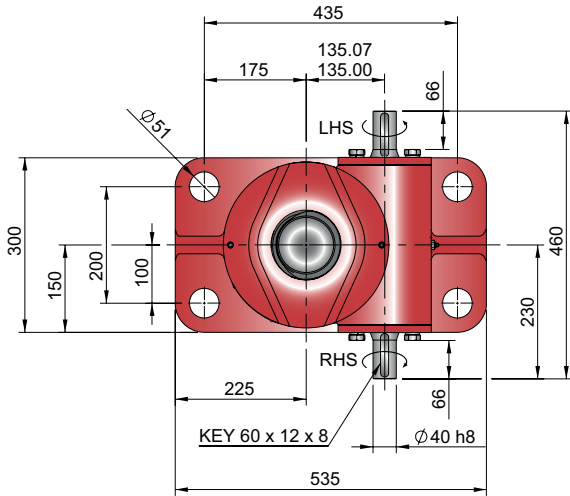

## Inverted EMT0500-I00

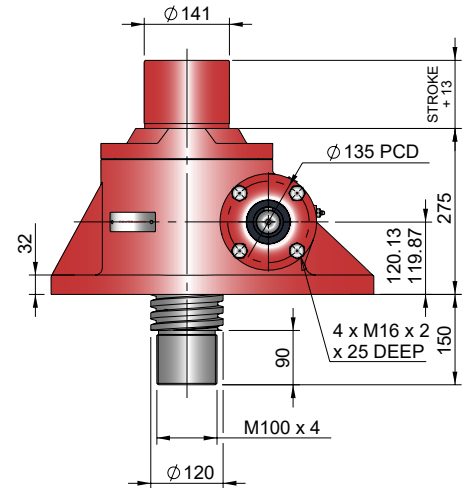
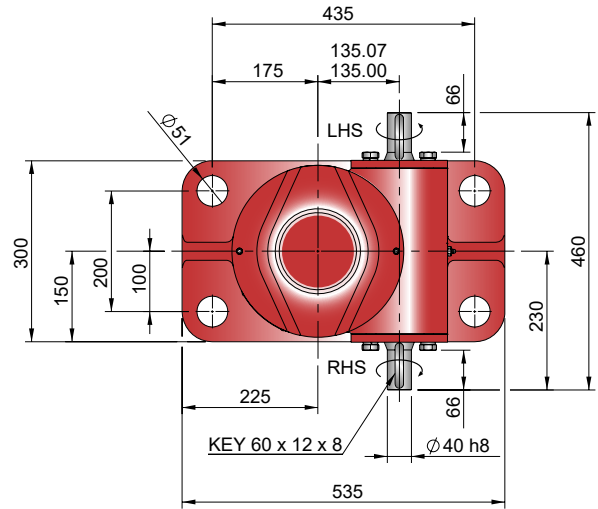

## Performance

Model		EMT0500 EMR0500	
Capacity	kN	500	
Lifting Screw	Diameter (mm)	120	
	Lead	Option	1   2
	mm	16	32
Gear Ratio Option 1	Gear Ratio	10 2/3:1	
	Static Efficiency	0.132	0.215
	Dynamic Efficiency	0.181	0.284
Gear Ratio Option 2	Gear Ratio	32:1	
	Static Efficiency	0.079	0.129
	Dynamic Efficiency	0.120	0.188
Max. Input power (kW)	Gear Ratio Option 1	11.25	
	Gear Ratio Option 2	4.5	
Start up torque at full load (Nm)	Gear Ratio Option 1	904	1113
	Gear Ratio Option 2	504	618

Model		EMT0500 EMR0500	
Capacity	kN	500	
Lifting Screw (mm)		16	32
Turn of worm for travel of lifting screw	Gear Ratio 1	1 Turn	1.5mm   3mm
	Gear Ratio 2	4 Turn	2mm   4mm
Maximum Through Torque (Nm)		2712	
Lifting Screw Restraining Torque (Nm)		5645	6975
Worm Shaft Maximum Radial Load (N)		2190	
Maximum Input Speed (rpm)		1800	
Gear Case Material		Steel	
Weight (kg) - stroke = 150mm	EMT	183.7	
	EMR	224	
Weight (kg) - per extra 25mm stroke	EMT	2.48	
	EMR	1.94	

Note: All dimension in millimetres unless otherwise stated.  
Designs subject to change without notice

## Closed Height

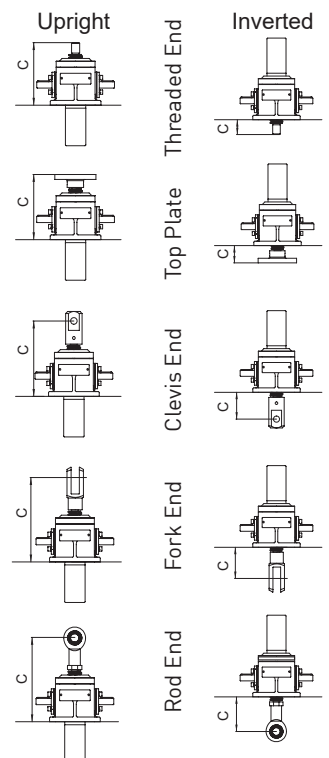

## Upright EMR0500-U00

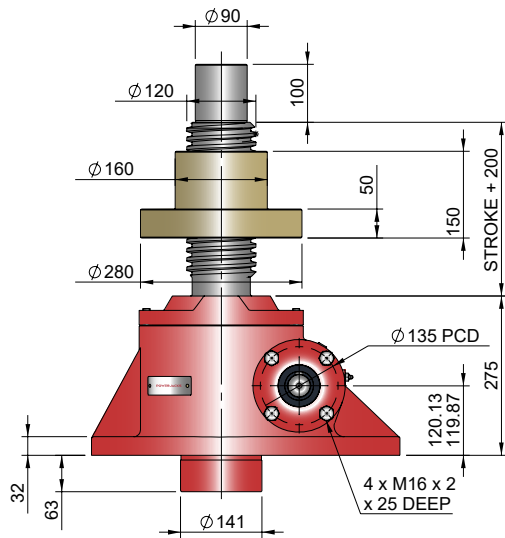
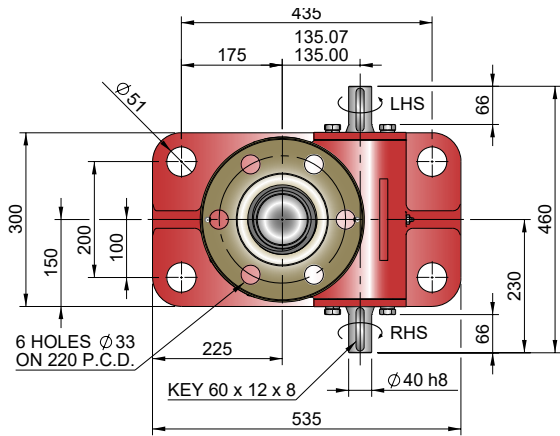

## Inverted EMR0500-I00

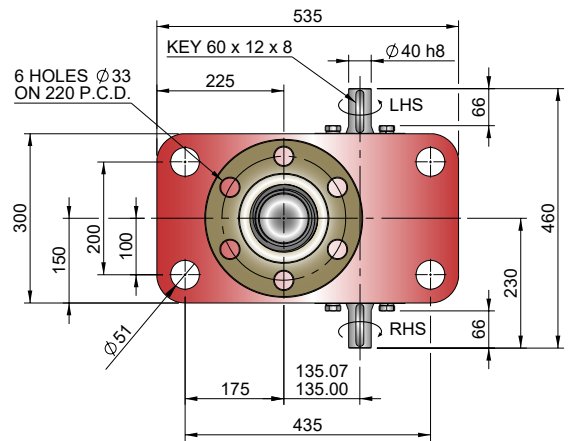
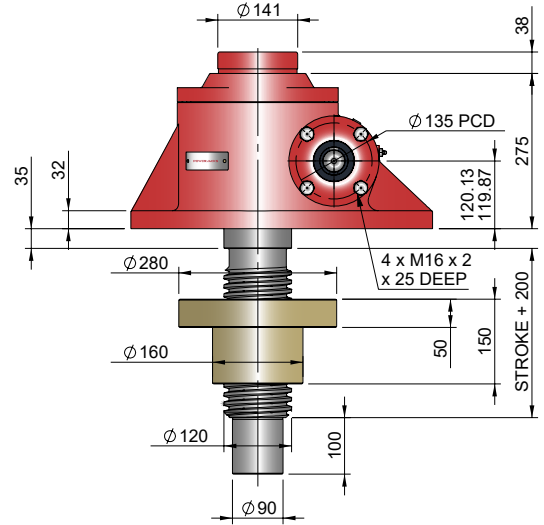

## Closed Height & Bellows Boots

Closed Height "C"	Threaded End		Top Plate		Clevis End		Fork End		Rod End	
	Upright	Inverted	Upright	Inverted	Upright	Inverted	Upright	Inverted	Upright	Inverted
EMT0500	390	150	390	150	440	200	on request		on request	
Stroke (mm)	EMT0500 with Bellows Boots									
1-300	390	175	390	175	440	225	-	-	-	-
301-600	415	200	415	200	465	250	-	-	-	-
601-1050	440	225	440	225	490	275	-	-	-	-
1051-1500	465	250	465	250	515	300	-	-	-	-

Model	A	B	D	E	G
EMT0500	150	285	20	45	210

Stroke	1-300	301-600	601-1050	1051-1500
EMT0500	20	30	50	70

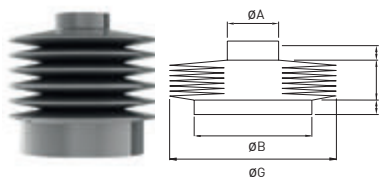

## Column Strength

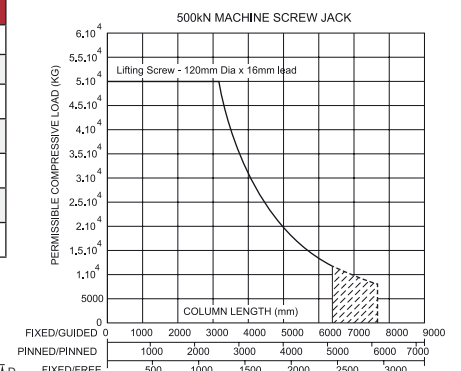

Note:

- 1 Inverted Screw Jacks - Bellows Boot Closed Height assumes screw jack mounted on a structure with thickness = 15mm
- 2 Inverted Screw Jacks - Recommended bellows boot mounting plate  $\varnothing B \times [E + 5mm]$  thick.
- 3 Inverted Screw Jacks - Screw Jack mounting plate & bellows boot mounting plate are customers own supply
- 4 † Control tapes fitted (increase outer diameter by 20mm approximately).
- 5 For horizontal installations with than 450 mm of stroke, internal boot guides are recommended.
- 6 Customers with threaded end screw jacks must provide a fixing for the unattached bellows boot collar.
- 7 Bellows boots for Rotating Screw Jacks, other sizes, stroke and materials please consult Power Jacks.

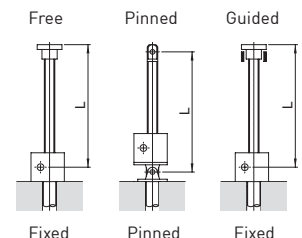

## Upright EMT1000-U00

## Inverted EMT1000-I00

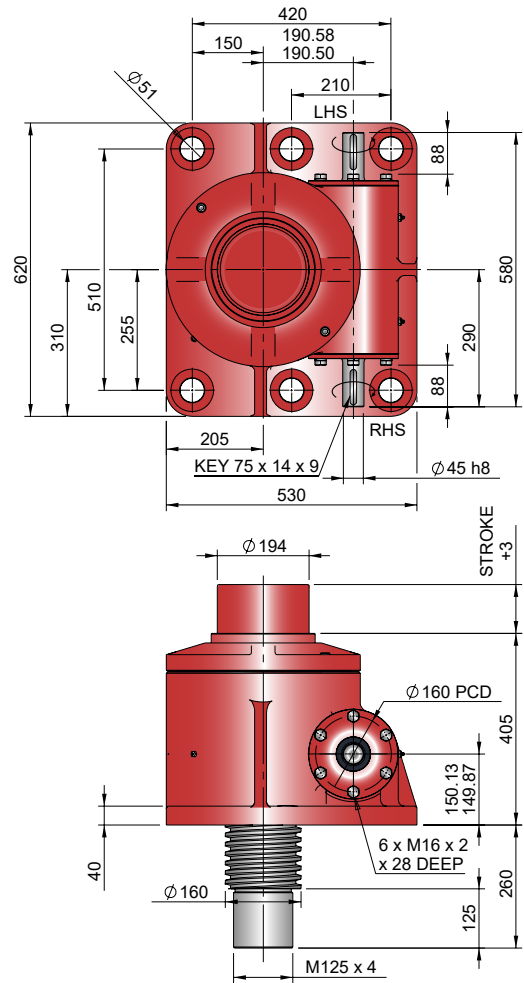
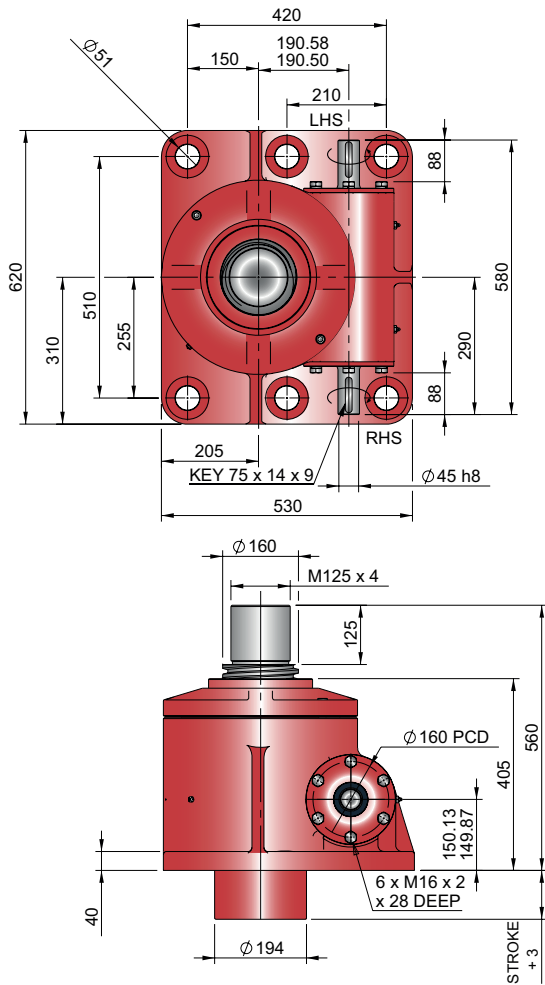

## Performance

## Closed Height

Model		EMT1000 EMR1000
Capacity	kN	1000
Lifting Screw	Diameter (mm)	160
	Lead	Option 1 mm 20
Gear Ratio Option 1	Gear Ratio	12:1
	Static Efficiency	0.131
	Dynamic Efficiency	0.178
Gear Ratio Option 2	Gear Ratio	36:1
	Static Efficiency	0.079
	Dynamic Efficiency	0.123
Max. Input power (kW)	Gear Ratio Option 1	18.5
	Gear Ratio Option 2	8.25
Start up torque at full load (Nm)	Gear Ratio Option 1	2025
	Gear Ratio Option 2	1119

Model		EMT1000 EMR1000
Capacity	kN	1000
Lifting Screw (mm)		20
Turn of worm for travel of lifting screw	Gear Ratio 1	1 Turn
	Gear Ratio 2	4 Turn
Maximum Through Torque (Nm)		6075
Lifting Screw Restraining Torque (Nm)		14890
Worm Shaft Maximum Radial Load (N)		2220
Maximum Input Speed (rpm)		1800
Gear Case Material		Steel
Weight (kg) - stroke = 150mm	EMT	459.1
	EMR	560.4
Weight (kg) - per extra 25mm stroke	EMT	4.11
	EMR	3.38

Note: All dimension in millimetres unless otherwise stated.  
Designs subject to change without notice

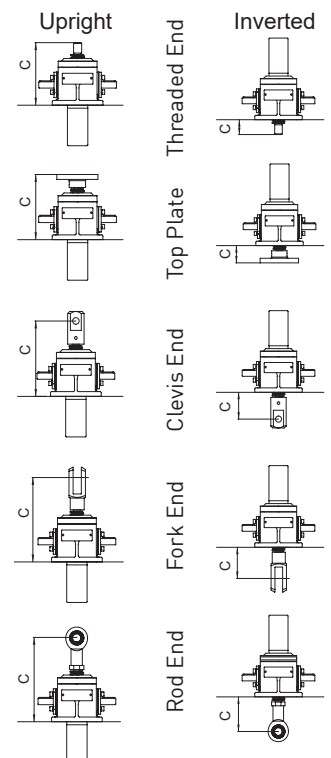



## Upright EMR1000-U00

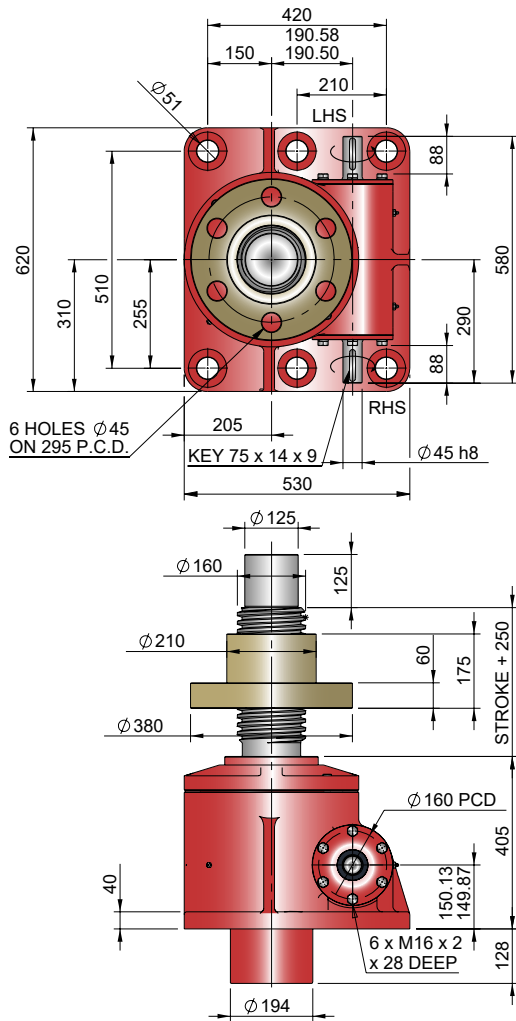

## Inverted EMR1000-I00

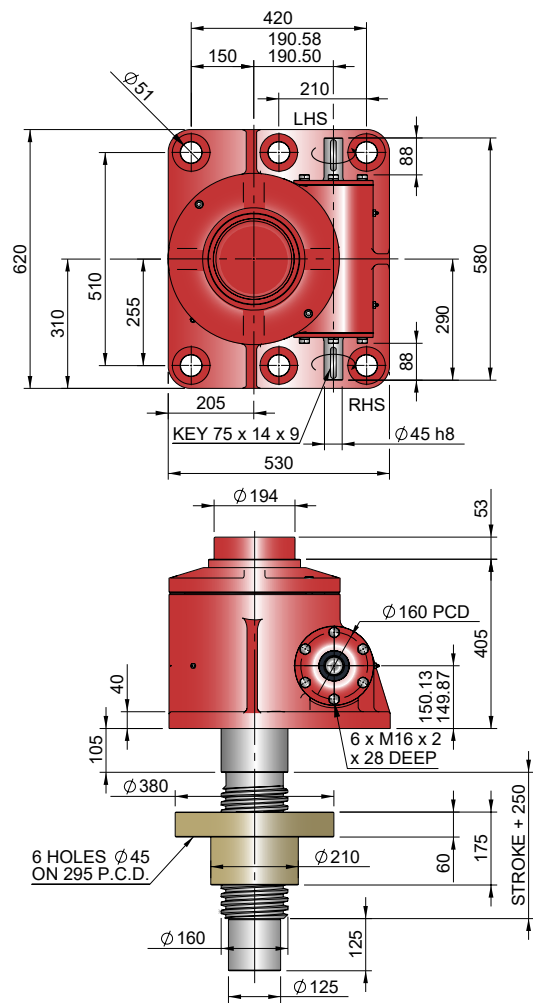

## Closed Height & Bellows Boots

Closed Height "C"	Threaded End		Top Plate		Clevis End		Fork End		Rod End	
	Upright	Inverted	Upright	Inverted	Upright	Inverted	Upright	Inverted	Upright	Inverted
EMT1000	560	260	560	260	625	325	on request		on request	
Stroke (mm)	EMT1000 with Bellows Boots									
1-300	560	260	560	260	625	325	-	-	-	-
301-600	560	260	560	260	625	325	-	-	-	-
601-1050	585	285	585	285	650	350	-	-	-	-
1051-1500	610	310	610	310	675	375	-	-	-	-

Model	A	B	D	E	G
EMT1000	200	220	20	20	244

Stroke	1-300	301-600	601-1050	1051-1500
EMT1000	20	30	50	70

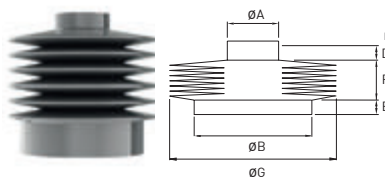

## Column Strength

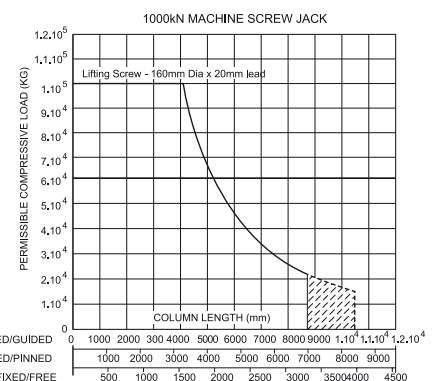

Note:

- 1 Inverted Screw Jacks - Bellows Boot Closed Height assumes screw jack mounted on a structure with thickness = 15mm
- 2 Inverted Screw Jacks - Recommended bellows boot mounting plate  $\phi B \times [E + 5mm]$  thick.
- 3 Inverted Screw Jacks - Screw Jack mounting plate & bellows boot mounting plate are customers own supply
- 4 † Control tapes fitted (increase outer diameter by 20mm approximately).
- 5 For horizontal installations with than 450 mm of stroke, internal boot guides are recommended.
- 6 Customers with threaded end screw jacks must provide a fixing for the unattached bellows boot collar.
- 7 Bellows boots for Rotating Screw Jacks, other sizes, stroke and materials please consult Power Jacks.

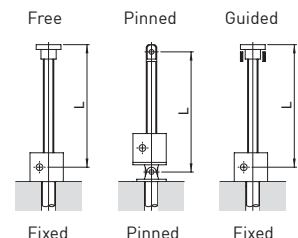

## Upright EMT1500-U00

## Inverted EMT1500-I00

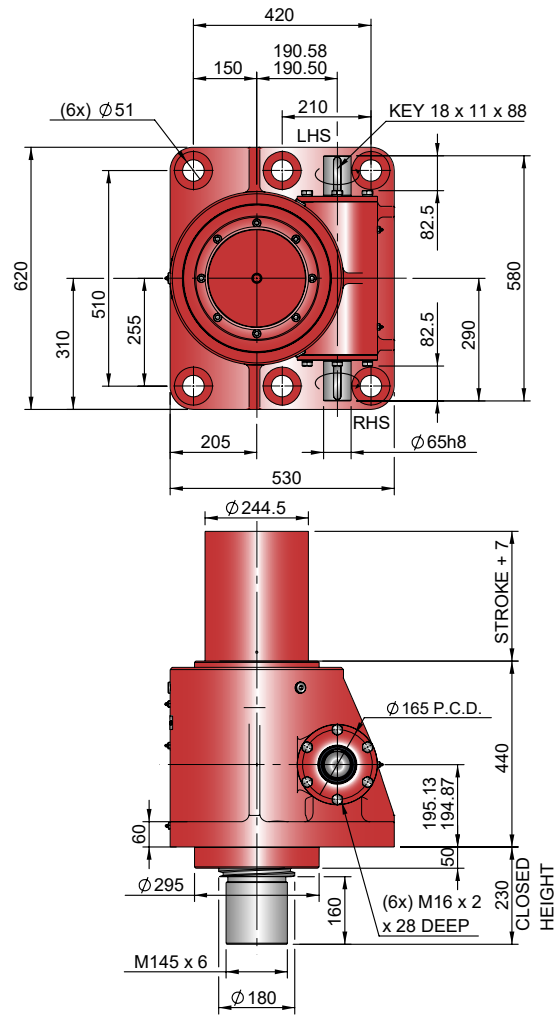
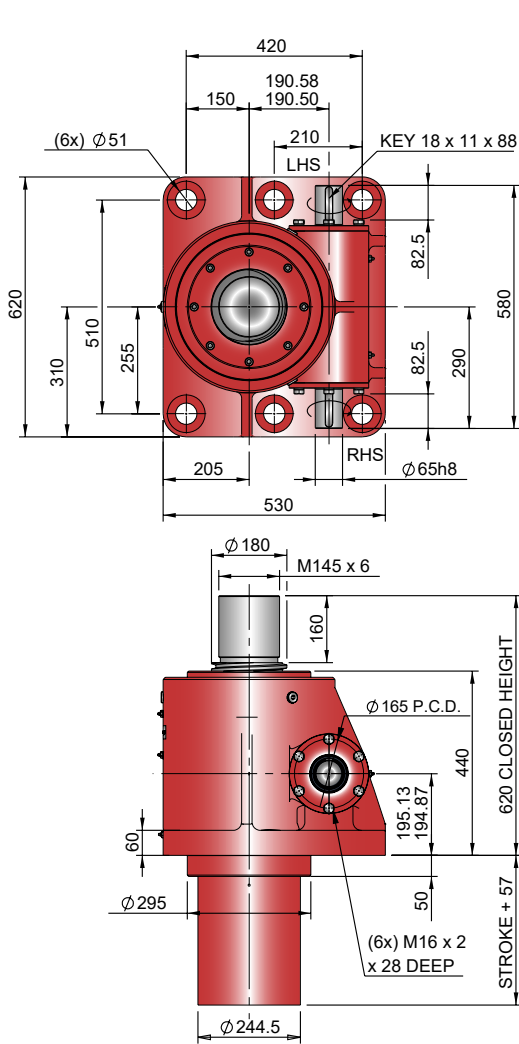

## Performance

## Closed Height

Model		EMT1500 EMR1500
Capacity	kN	1500
Lifting Screw	Diameter (mm)	180
	Lead	Option 1 20
Gear Ratio Option 1	Gear Ratio	11.67:1
	Static Efficiency	0.112
	Dynamic Efficiency	0.155
Gear Ratio Option 2	Gear Ratio	on request
	Static Efficiency	on request
	Dynamic Efficiency	on request
Max. Input power (kW)	Gear Ratio Option 1	25.3
	Gear Ratio Option 2	on request
Start up torque at full load (Nm)	Gear Ratio Option 1	3655
	Gear Ratio Option 2	on request

Model		EMT1500 EMR1500
Capacity	kN	1500
Lifting Screw (mm)		20
Turn of worm for travel of lifting screw	Gear Ratio 1	1 Turn
	Gear Ratio 2	4 Turn
Maximum Through Torque (Nm)		7310
Lifting Screw Restraining Torque (Nm)		24610
Worm Shaft Maximum Radial Load (N)		4450
Maximum Input Speed (rpm)		1000
Gear Case Material		Steel
Weight (kg) - stroke = 150mm	EMT	563
	EMR	708
Weight (kg) - per extra 25mm stroke	EMT	5.80
	EMR	4.40

Note: All dimension in millimetres unless otherwise stated.  
Designs subject to change without notice

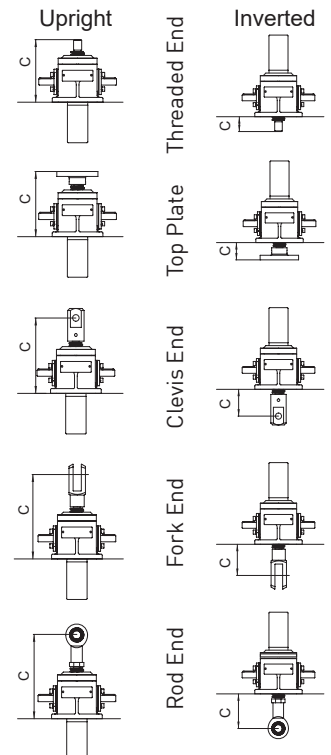

## Upright EMR1500-U00

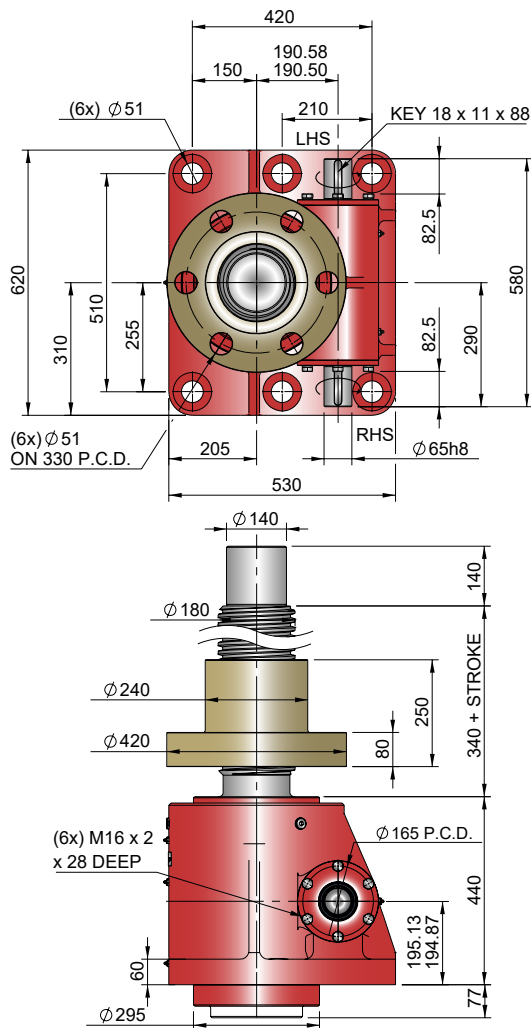

## Inverted EMR1500-I00

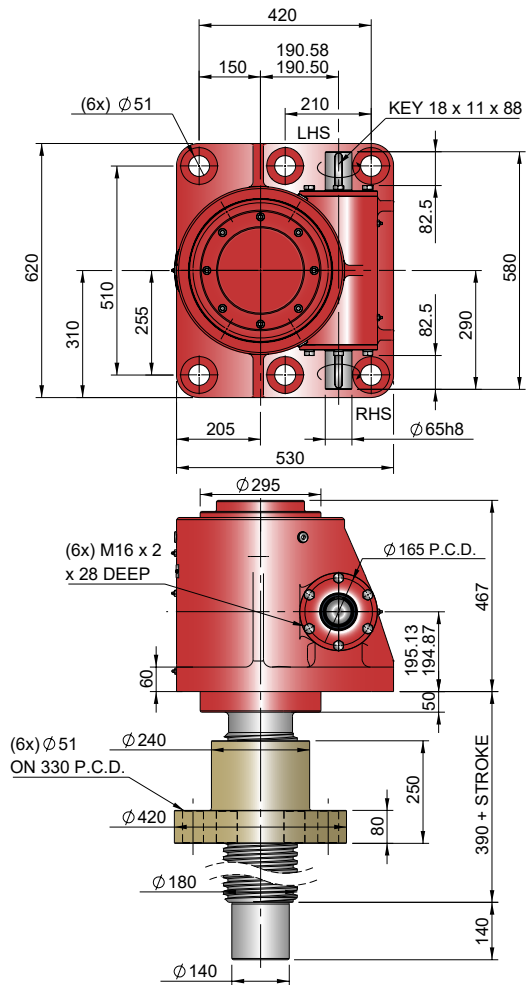

## Closed Height & Bellows Boots

Closed Height "C"	Threaded End		Top Plate		Clevis End		Fork End		Rod End	
	Upright	Inverted	Upright	Inverted	Upright	Inverted	Upright	Inverted	Upright	Inverted
EMT1500	620	230	620	230	760	370	on request		on request	
Stroke (mm)	EMT1500 with Bellows Boots									
1-500	620	230	620	230	760	370	-	-	-	-
501-1000	630	255	630	255	770	395	-	-	-	-
1001-2000	665	290	665	290	805	430	-	-	-	-
2001-4000	745	370	745	370	885	510	-	-	-	-

Model	A	B	D	E	G
EMT1500	215	410	25	25	480

Stroke	1-500	751-1000	1001-2000	2001-4000
EMT1500	20	45	80	160

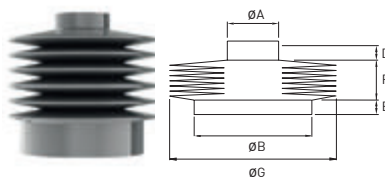

## Column Strength

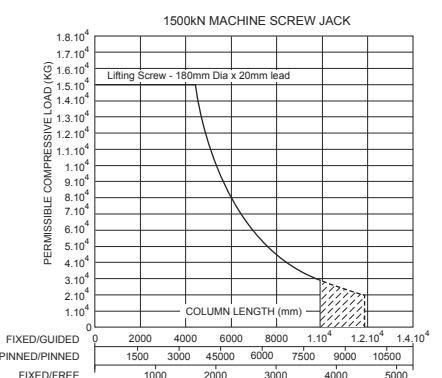

Note:

- 1 Inverted Screw Jacks - Bellows Boot Closed Height assumes screw jack mounted on a structure with thickness = 15mm
- 2 Inverted Screw Jacks - Recommended bellows boot mounting plate ØB x [E +5mm] thick.
- 3 Inverted Screw Jacks - Screw Jack mounting plate & bellows boot mounting plate are customers own supply
- 4 † Control tapes fitted (increase outer diameter by 20mm approximately).
- 5 For horizontal installations with than 450 mm of stroke, internal boot guides are recommended.
- 6 Customers with threaded end screw jacks must provide a fixing for the unattached bellows boot collar.
- 7 Bellows boots for Rotating Screw Jacks, other sizes, stroke and materials please consult Power Jacks.

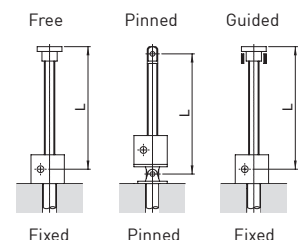

## Upright EMT2000-U00

## Inverted EMT2000-I00

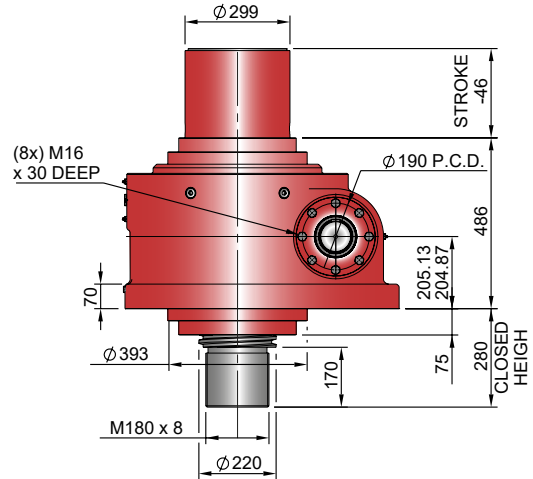
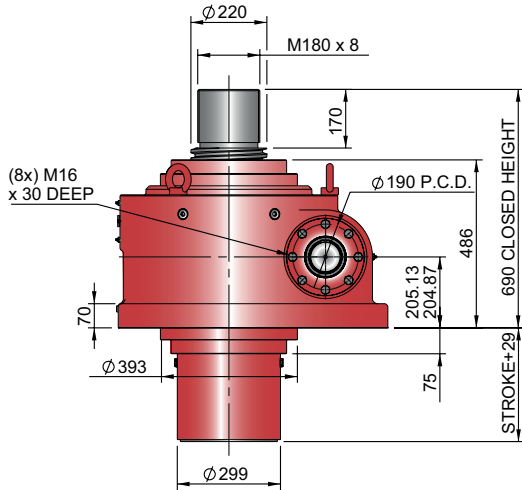
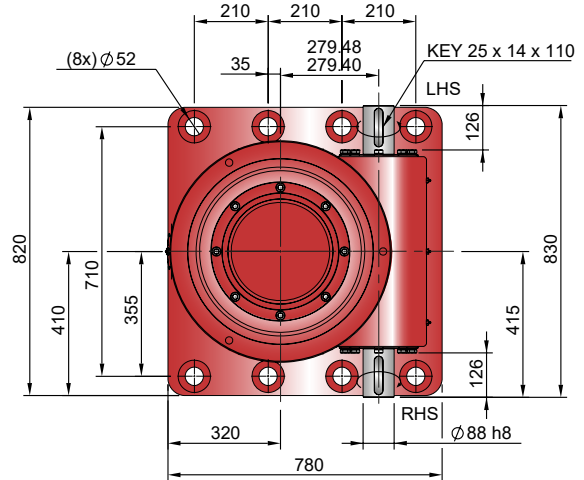
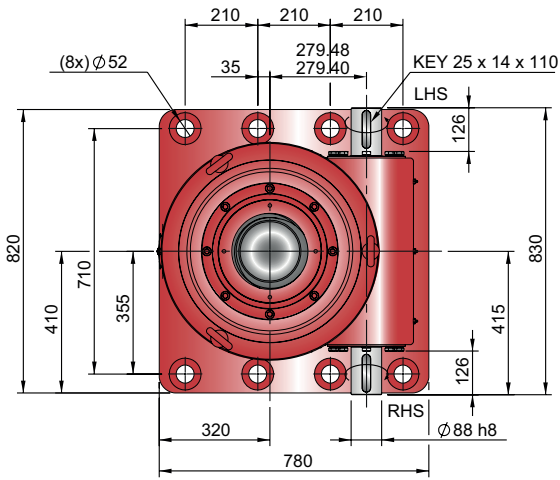

## Performance

## Closed Height

Model		EMT2000 EMR2000
Capacity	kN	2000
Lifting Screw	Diameter (mm)	220
	Lead	Option 1 24
Gear Ratio Option 1	Gear Ratio	18:1
	Static Efficiency	0.109
	Dynamic Efficiency	0.151
Gear Ratio Option 2	Gear Ratio	on request
	Static Efficiency	on request
	Dynamic Efficiency	on request
Max. Input power (kW)	Gear Ratio Option 1	32.5
	Gear Ratio Option 2	on request
Start up torque at full load (Nm)	Gear Ratio Option 1	3895
	Gear Ratio Option 2	on request

Model		EMT2000 EMR2000
Capacity	kN	2000
Lifting Screw (mm)		24
Turn of worm for travel of lifting screw	Gear Ratio 1	1 Turn
	Gear Ratio 2	4 Turn
Maximum Through Torque (Nm)		7790
Lifting Screw Restraining Torque (Nm)		39995
Worm Shaft Maximum Radial Load (N)		7800
Maximum Input Speed (rpm)		600
Gear Case Material		Steel
Weight (kg) - stroke = 150mm	EMT	1172
	EMR	1534
Weight (kg) - per extra 25mm stroke	EMT	9.00
	EMR	6.50

Note: All dimension in millimetres unless otherwise stated.  
Designs subject to change without notice

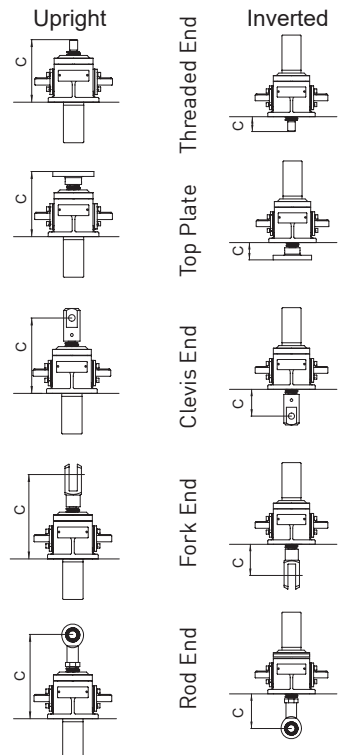

## Upright EMR2000-U00

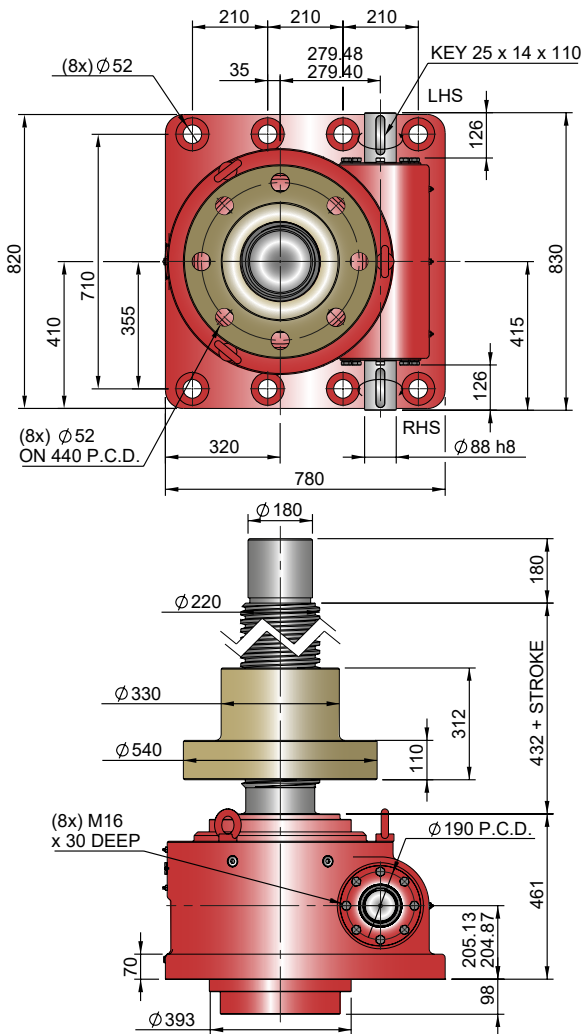

## Inverted EMR2000-I00

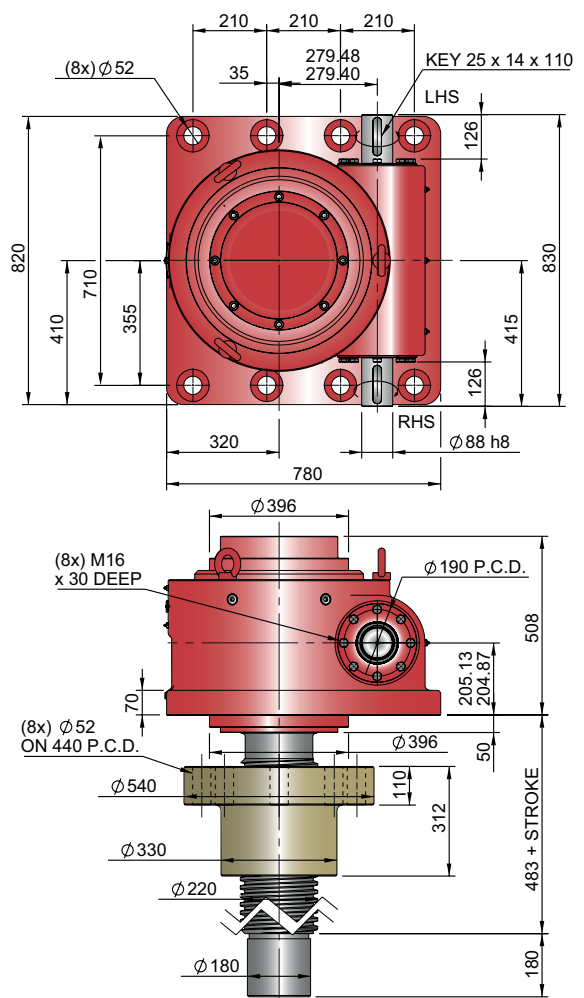

## Closed Height & Bellows Boots

Closed Height "C"	Threaded End		Top Plate		Clevis End		Fork End		Rod End	
	Upright	Inverted	Upright	Inverted	Upright	Inverted	Upright	Inverted	Upright	Inverted
EMT2000	690	280	690	280	880	470	on request		on request	
Stroke (mm)	EMT2000 with Bellows Boots									
1-500	690	280	690	280	880	470	-	-	-	-
501-1000	690	280	690	280	880	470	-	-	-	-
1001-2000	695	285	695	285	885	475	-	-	-	-
2001-4000	795	350	795	350	985	540	-	-	-	-

Model	A	B	D	E	G
EMT2000	265	396	25	25	470

Stroke	1-500	751-1000	1001-2000	2001-4000
EMT2000	25	40	75†	145†

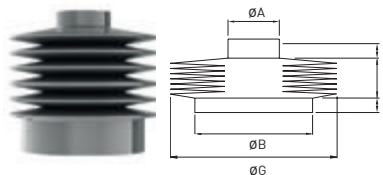

## Column Strength

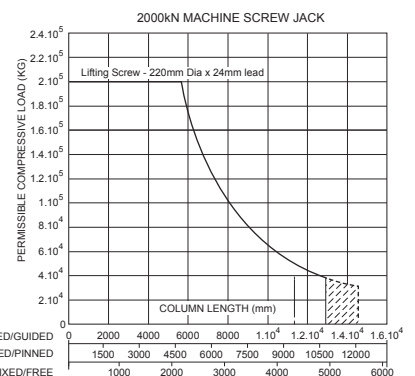

Note:

- 1 Inverted Screw Jacks - Bellows Boot Closed Height assumes screw jack mounted on a structure with thickness = 15mm
- 2 Inverted Screw Jacks - Recommended bellows boot mounting plate ØB x [E +5mm] thick.
- 3 Inverted Screw Jacks - Screw Jack mounting plate & bellows boot mounting plate are customers own supply
- 4 † Control tapes fitted (increase outer diameter by 20mm approximately).
- 5 For horizontal installations with than 450 mm of stroke, internal boot guides are recommended.
- 6 Customers with threaded end screw jacks must provide a fixing for the unattached bellows boot collar.
- 7 Bellows boots for Rotating Screw Jacks, other sizes, stroke and materials please consult Power Jacks.

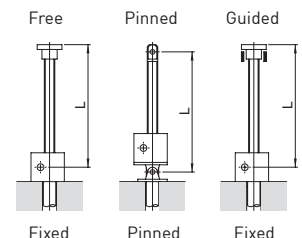

E-Series

3

## E-Series Metric Machine Screw Jack

PERFORMANCE  
ENHANCED VARIANTS  
TO SOLVE SPECIFIC  
APPLICATION  
REQUIREMENTS



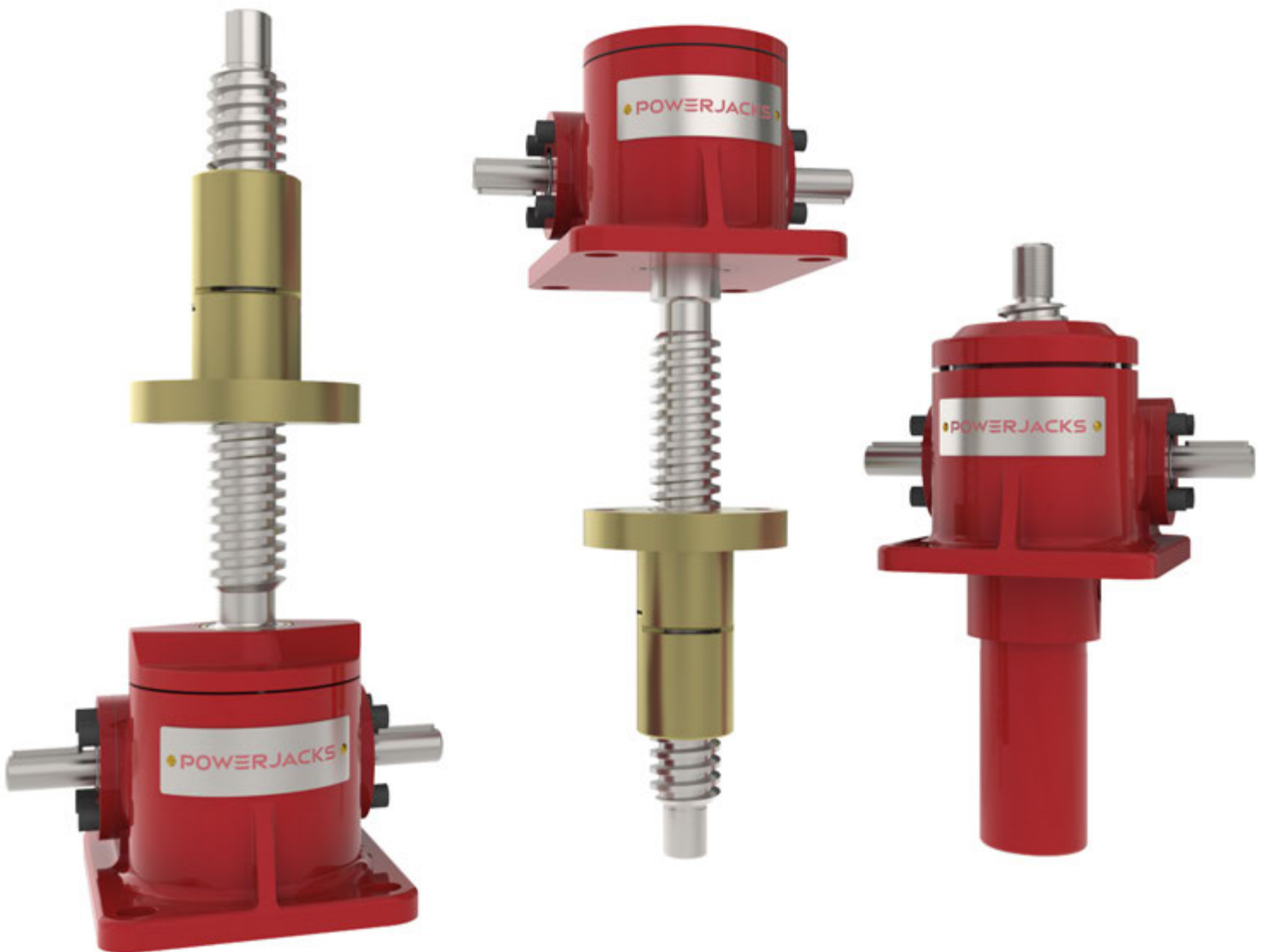

## Minimise Axial Backlash for Reversing Loads

The Anti-Backlash feature provides a reliable method to regulate the axial backlash in a screw jack for applications where there is a reversal of loading from tension to compression. The amount of backlash between the screw and worm gear nut can be adjusted (adjust shell cap) to a desired amount or a practical minimum. To avoid binding and excessive wear do not adjust backlash to less than 0.025mm.

The Anti-Backlash feature also acts as a safety device, providing dual nut load carrying unit, when the worm gear becomes worn.

A visual wear indicator is available on request for all models and a "feeler" gauge can be used to measure the wear. This can be upgraded to use a sensor for wear monitoring. Consult Power Jacks for either option.

Anti-Backlash Nut      Anti-Backlash Gear

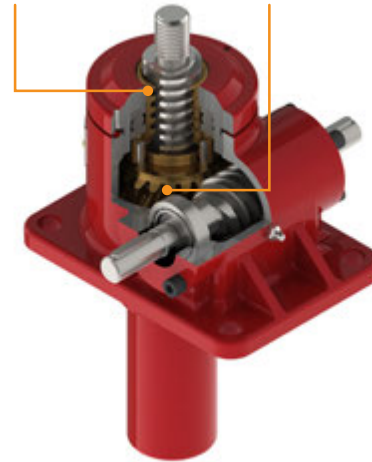

## Dimensions

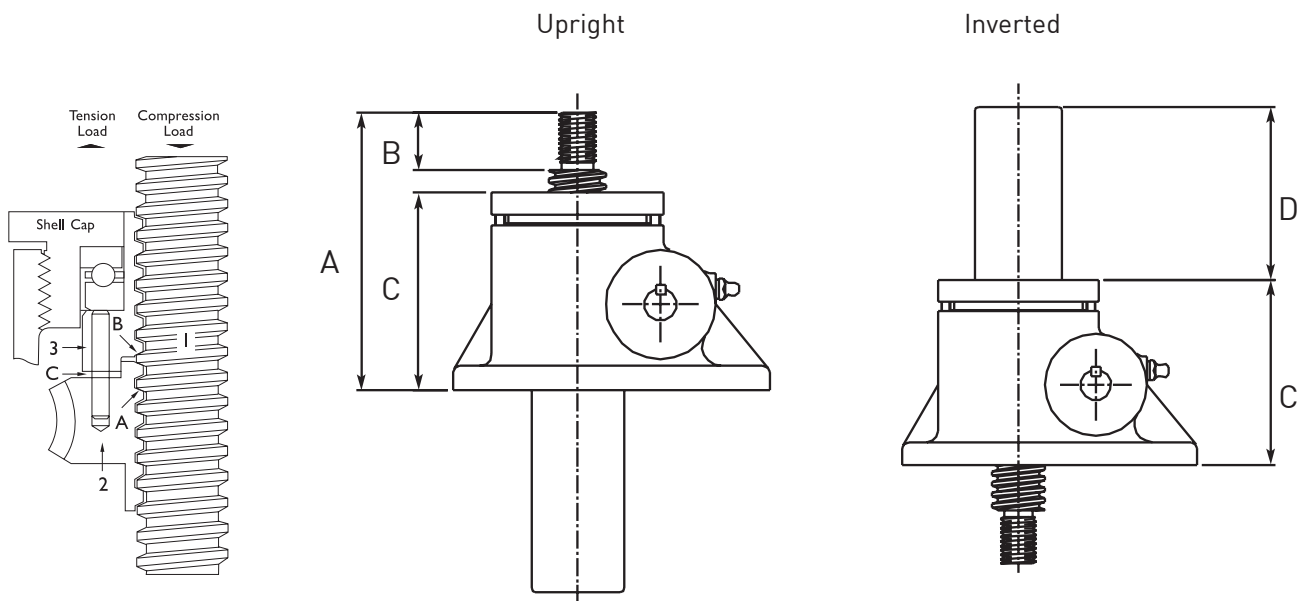

How it works - refer p193

The dimensions for these screw jacks are the same as the standard units except those detailed below.

Model	EMT0005	EMT0010	EMT0025	EMT0050	EMT0100	EMT0200	EMT0300	EMT0500	EMT1000	EMT1500	EMT2000
A	95	125	145	185	200	265	340	415	585	833	910
B	20	24	30	35	40	55	65	90	125	160	170
C	65	86	103.5	138	146.5	195	250	295	415	652	709
D	Stroke + 34	Stroke + 35	Stroke + 30	Stroke + 20	Stroke + 3	Stroke + 24	Stroke + 38	Stroke + 28	Stroke + 3	Stroke + 7	Stroke - 46

## E-Series - Machine Screw Jacks - Anti-Backlash - Performance

Model		EMT0005-U0A EMT0005-I0A		EMT0010-U0A EMT0010-I0A		EMT0025-U0A EMT0025-I0A		EMT0050-U0A EMT0050-I0A		EMT0100-U0A EMT0100-I0A		
Capacity	kN	5		10		25		50		100		
Lifting Screw <sup>1</sup>	mm	16		20		30		40		55		
	Lead	Option	1	2	1	2	1	2	1	2	1	2
		mm	3	6	5	10	6	12	9	18	12	24
Gear Ratios	Option 1	5:1		5:1		6:1		6:1		8:1		
	Option 2	20:1		20:1		24:1		24:1		24:1		
Max. Input Power (kW)	Gear Ratio Option 1	0.25		0.375		1.5		3.0		3.75		
	Gear Ratio Option 2	0.12		0.19		0.375		0.55		1.125		
Start up torque at full load (Nm) <sup>2</sup>	Gear Ratio Option 1	2.9	3.8	7.8	10.9	23.5	31.3	62.3	84.9	129.2	147.8	
	Gear Ratio Option 2	1.3	1.7	3.6	5.1	9.8	13.0	28.5	38.8	66.8	90.4	
Weight (kg) - stroke = 150mm		1.48		2.72		8.62		16.78		26.12		
Weight (kg) per extra 25mm		0.073		0.13		0.21		0.32		0.57		
Gear Ratio Option 1	Gear Ratio	5:1		5:1		6:1		6:1		8:1		
	Screw Jack Static Efficiency	0.164	0.249	0.203	0.291	0.169	0.254	0.192	0.281	0.185	0.273	
	Screw Jack Dynamic Efficiency	0.216	0.317	0.263	0.365	0.222	0.322	0.251	0.356	0.243	0.325	
Gear Ratio Option 2	Gear Ratio	20:1		20:1		24:1		24:1		24:1		
	Screw Jack Static Efficiency	0.090	0.137	0.109	0.157	0.102	0.153	0.105	0.154	0.119	0.176	
	Screw Jack Dynamic Efficiency	0.133	0.195	0.159	0.220	0.150	0.217	0.154	0.218	0.172	0.245	

Model		EMT0200-U0A EMT0200-I0A		EMT0300-U0A EMT0300-I0A		EMT0500-U0A EMT0500-I0A		EMT1000-U0A EMT1000-I0A		EMT1500-U0A EMT1500-I0A		EMT2000-U0A EMT2000-I0A	
Capacity	kN	200		300		500		1000		1500		2000	
Lifting Screw <sup>1</sup>	mm	65		95		120		160		180		220	
	Lead	Option	1	2	1	2	1	2	1	1	1	1	1
		mm	12	24	16	32	16	32	20	20	20	24	24
Gear Ratios	Option 1	8:1		10 2/3:1		10 2/3:1		12:1		11 2/3:1		18:1	
	Option 2	24:1		32:1		32:1		36:1		N/A		N/A	
Max. Input Power (kW)	Gear Ratio Option 1	3.75		6.0		11.25		18.5		25.3		32.5	
	Gear Ratio Option 2	1.125		1.9		4.5		8.25		N/A		N/A	
Start up torque at full load (Nm) <sup>2</sup>	Gear Ratio Option 1	281.2	368.5	534	687	1000	1236	2243	4061	4328			
	Gear Ratio Option 2	153.7	201.4	315	405	568	702	1244	N/A	N/A			
Weight (kg) - stroke = 150mm		49		91		209		610		620		1290	
Weight (kg) per extra 25mm		0.86		1.58		2.49		4.31		5.80		9.00	
Gear Ratio Option 1	Gear Ratio	8:1		10 2/3:1		10 2/3:1		12:1		11 2/3:1		18:1	
	Screw Jack Static Efficiency	0.170	0.259	0.134	0.209	0.119	0.193	0.118	0.100	0.098			
	Screw Jack Dynamic Efficiency	0.226	0.332	0.184	0.277	0.163	0.256	0.160	0.139	0.136			
Gear Ratio Option 2	Gear Ratio	24:1		32:1		32:1		36:1		N/A		N/A	
	Screw Jack Static Efficiency	0.104	0.158	0.076	0.118	0.070	0.113	0.071	N/A		N/A		
	Screw Jack Dynamic Efficiency	0.151	0.222	0.115	0.173	0.105	0.165	0.106	N/A		N/A		

**Note**

1. All metric machine screws have a trapezoidal thread form.
2. For loads of 25% to 100% of screw jack capacity, torque requirements are approximately proportional to the load.
3. Efficiency values for standard grease lubricated worm gear box and lifting screw.
4. All E-Series screw jacks have grease lubricated gearbox and lead screw as standard.

### Linear Movement for Rationally Unconstrained Loads

The Anti-Rotation feature for translating screw jacks stops the lifting screw from rotating without the need for end fixing. This is done by keying the lifting screw.

Benefits:

- Compact unit integrates anti-rotation into gearbox
- Dimensions are the same as the standard translating screw jack
- Standard round cover pipe for easy installation
- Proven industrial anti-rotation design

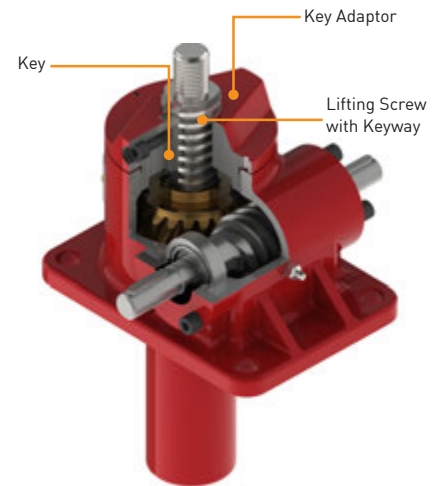

### Dimensions

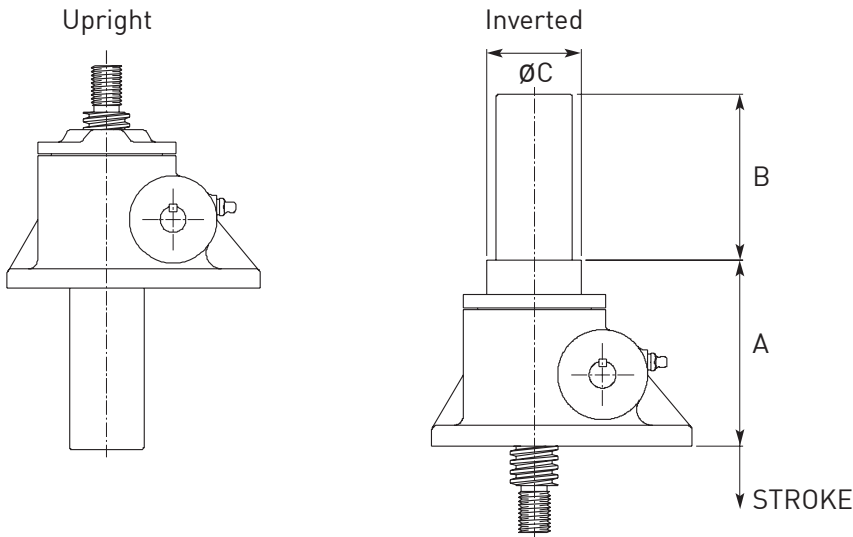

### Dimensions for Upright Models with Anti-Rotation (Keyed)

Dimensions for upright E-Series machine screw jacks with anti-rotation (keyed) mechanism are the same as the standard screw jacks without the feature.

### Dimensions for Inverted Models with Anti-Rotation (Keyed)

The dimensions for these screw jacks are the same as the standard units except those detailed below.

Model	EMT0005	EMT0010	EMT0025	EMT0050	EMT0100	EMT0200	EMT0300	EMT0500	EMT1000	EMT1500	EMT2000
A	79	78	125.5	159	167.5	210	267	307	445	440	486
B	Stroke + 9	Stroke + 35	Stroke + 30	Stroke + 20	Stroke + 3	Stroke - 1	Stroke + 15	Stroke + 13	Stroke + 3	Stroke + 7	Stroke - 46
øC	35	N/A	60	75	90	102	141.5	180	236	295	396

## E-Series - Machine Screw Jacks - Anti-Rotation (Keyed) - Performance

Model		EMT0005-UK0 EMT0005-IK0		EMT0010-UK0 EMT0010-IK0		EMT0025-UK0 EMT0025-IK0		EMT0050-UK0 EMT0050-IK0		EMT0100-UK0 EMT0100-IK0		
Capacity	kN	5		10		25		50		100		
Lifting Screw <sup>1</sup>	mm	16		20		30		40		55		
	Lead	Option	1	2	1	2	1	2	1	2	1	2
		mm	3	6	5	10	6	12	9	18	12	24
Gear Ratios	Option 1	5:1		5:1		6:1		6:1		8:1		
	Option 2	20:1		20:1		24:1		24:1		24:1		
Max. Input Power (kW)	Gear Ratio Option 1	0.25		0.375		1.5		3.0		3.75		
	Gear Ratio Option 2	0.12		0.19		0.375		0.55		1.125		
Start up torque at full load (Nm) <sup>2</sup>	Gear Ratio Option 1	2.9	3.8	7.1	9.9	20.8	27.7	58.7	80	121.7	164.7	
	Gear Ratio Option 2	1.3	1.7	3.1	4.4	9.2	12.2	26.8	36.6	63.6	86.1	
Weight (kg) - stroke = 150mm		1.03		2.27		8.17		15.88		24.72		
Weight (kg) per extra 25mm		0.073		0.13		0.21		0.32		0.57		
Gear Ratio Option 1	Gear Ratio	5:1		5:1		6:1		6:1		8:1		
	Screw Jack Static Efficiency	0.182	0.277	0.224	0.322	0.191	0.287	0.203	0.299	0.196	0.290	
	Screw Jack Dynamic Efficiency	0.240	0.352	0.291	0.403	0.251	0.364	0.267	0.378	0.258	0.368	
Gear Ratio Option 2	Gear Ratio	20:1		20:1		24:1		24:1		24:1		
	Screw Jack Static Efficiency	0.103	0.157	0.127	0.182	0.108	0.162	0.111	0.163	0.125	0.185	
	Screw Jack Dynamic Efficiency	0.152	0.223	0.184	0.255	0.159	0.230	0.164	0.232	0.180	0.257	

Model		EMT0200-UK0 EMT0200-IK0		EMT0300-UK0 EMT0300-IK0		EMT0500-UK0 EMT0500-IK0		EMT1000-UK0 EMT1000-IK0		EMT1500-UK0 EMT1500-IK0		EMT2000-UK0 EMT2000-IK0	
Capacity	kN	200		300		500		1000		1500		2000	
Lifting Screw <sup>1</sup>	mm	65		95		120		160		180		220	
	Lead	Option	1	2	1	2	1	2	1	1	1	1	1
		mm	12	24	16	32	16	32	20	20	20	24	24
Gear Ratios	Option 1	8:1		10 2/3:1		10 2/3:1		12:1		11 2/3:1		18:1	
	Option 2	24:1		32:1		32:1		36:1		N/A		N/A	
Max. Input Power (kW)	Gear Ratio Option 1	3.75		6.0		11.25		18.5		25.3		32.5	
	Gear Ratio Option 2	1.125		1.9		4.5		8.25		N/A		N/A	
Start up torque at full load (Nm) <sup>2</sup>	Gear Ratio Option 1	275.3	360.7	506	651	947	1170	2125	3847	4100	4100	4100	
	Gear Ratio Option 2	144	188.7	298	384	526	650	1126	N/A	N/A	N/A		
Weight (kg) - stroke = 150mm		45		86		195		553		563		1172	
Weight (kg) per extra 25mm		0.86		1.58		2.49		4.31		5.80		9.00	
Gear Ratio Option 1	Gear Ratio	8:1		10 2/3:1		10 2/3:1		12:1		11 2/3:1		18:1	
	Screw Jack Static Efficiency	0.173	0.265	0.142	0.220	0.126	0.204	0.125	0.106	0.103	0.103		
	Screw Jack Dynamic Efficiency	0.230	0.34	0.195	0.292	0.172	0.270	0.169	0.147	0.143			
Gear Ratio Option 2	Gear Ratio	24:1		32:1		32:1		36:1		N/A		N/A	
	Screw Jack Static Efficiency	0.111	0.169	0.080	0.124	0.076	0.122	0.079	N/A	N/A	N/A		
	Screw Jack Dynamic Efficiency	0.161	0.237	0.121	0.182	0.144	0.178	0.117	N/A	N/A			

**Note**

1. All metric machine screws have a trapezoidal thread form.
2. For loads of 25% to 100% of screw jack capacity, torque requirements are approximately proportional to the load.
3. Efficiency values for standard grease lubricated worm gear box and lifting screw.
4. All E-Series screw jacks have grease lubricated gearbox and lead screw as standard.

### Combine Anti-Backlash & Anti-Rotation in One Screw Jack

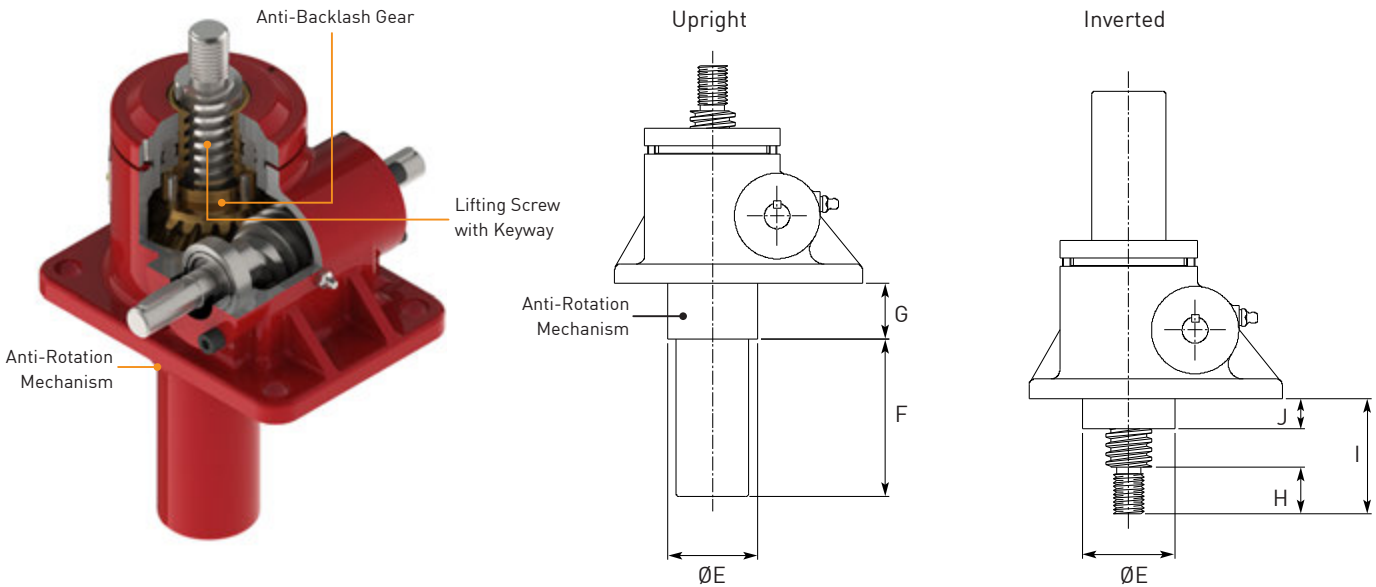

### Dimensions for E-Series Machine Screw Jacks with Anti-Backlash & Anti-Rotation

Model	EMT0005-UKA EMT0005-IKA	EMT0010-UKA EMT0010-IKA	EMT0025-UKA EMT0025-IKA	EMT0050-UKA EMT0050-IKA	EMT0100-UKA EMT0100-IKA	EMT0200-UKA EMT0200-IKA
ØE	36	38	60	75	90	102
F	Stroke + 9	Stroke + 9	Stroke + 30	Stroke + 20	Stroke + 28	Stroke + 24
G	25	30	37	40	37	58
H	20	24	30	35	30	55
I	40	45	55	65	55	110
J	16	16	19.5	24	19.5	39

Model	EMT0300-UKA EMT0300-IKA	EMT0500-UKA EMT0500-IKA	EMT1000-UKA EMT1000-IKA	EMT1500-UKA EMT1500-IKA	EMT2000-UKA EMT2000-IKA
ØE	138	206	264	295	396
F	Stroke + 15	Stroke + 13	Stroke + 28	Stroke + 7	Stroke - 15
G	73	58	180	50	201
H	65	55	125	160	170
I	115	110	405	286	395
J	43	39	145	106	200

The dimensions for these screw jacks are the same as the Anti-Backlash units except those detailed above.



## E-Series - Machine Screw Jacks - Anti-Backlash &amp; Anti-Rotation (Keyed) - Performance

Model		EMT0005-UKA EMT0005-IKA		EMT0010-UKA EMT0010-IKA		EMT0025-UKA EMT0025-IKA		EMT0050-UKA EMT0050-IKA		EMT0100-UKA EMT0100-IKA		
Capacity	kN	5		10		25		50		100		
Lifting Screw <sup>1</sup>	mm	16		20		30		40		55		
	Lead	Option	1	2	1	2	1	2	1	2	1	2
		mm	3	6	5	10	6	12	9	18	12	24
Gear Ratios	Option 1	5:1		5:1		6:1		6:1		8:1		
	Option 2	20:1		20:1		24:1		24:1		24:1		
Max. Input Power (kW)	Gear Ratio Option 1	0.25		0.375		1.5		3.0		3.75		
	Gear Ratio Option 2	0.12		0.19		0.375		0.55		1.125		
Start up torque at full load (Nm) <sup>2</sup>	Gear Ratio Option 1	3.1	4	8.3	11.5	24.8	33	65.6	89.3	136	184	
	Gear Ratio Option 2	1.4	1.8	3.8	5.3	10.3	13.7	30	40.9	70.3	95.2	
Weight (kg) - stroke = 150mm		1.48		2.72		8.62		16.78		26.12		
Weight (kg) per extra 25mm		0.073		0.13		0.21		0.32		0.57		
Gear Ratio Option 1	Gear Ratio	5:1		5:1		6:1		6:1		8:1		
	Screw Jack Static Efficiency	0.156	0.237	0.193	0.277	0.161	0.241	0.182	0.267	0.176	0.259	
	Screw Jack Dynamic Efficiency	0.205	0.301	0.250	0.346	0.211	0.306	0.239	0.338	0.231	0.330	
Gear Ratio Option 2	Gear Ratio	20:1		20:1		24:1		24:1		24:1		
	Screw Jack Static Efficiency	0.086	0.130	0.104	0.149	0.097	0.145	0.100	0.146	0.113	0.167	
	Screw Jack Dynamic Efficiency	0.126	0.185	0.151	0.209	0.142	0.206	0.146	0.208	0.163	0.233	

Model		EMT0200-UKA EMT0200-IKA		EMT0300-UKA EMT0300-IKA		EMT0500-UKA EMT0500-IKA		EMT1000-UKA EMT1000-IKA		EMT1500-UKA EMT1500-IKA		EMT2000-UKA EMT2000-IKA	
Capacity	kN	200		300		500		1000		1500		2000	
Lifting Screw <sup>1</sup>	mm	65		95		120		160		180		220	
	Lead	Option	1	2	1	2	1	2	1	1	1	1	1
		mm	12	24	16	32	16	32	20	20	20	24	24
Gear Ratios	Option 1	8:1		10 2/3:1		10 2/3:1		12:1		11 2/3:1		18:1	
	Option 2	24:1		32:1		32:1		36:1		N/A		N/A	
Max. Input Power (kW)	Gear Ratio Option 1	3.75		6.0		11.25		18.5		25.3		32.5	
	Gear Ratio Option 2	1.125		1.9		4.5		8.25		N/A		N/A	
Start up torque at full load (Nm) <sup>2</sup>	Gear Ratio Option 1	296	387.9	562	723	1052	1301	2361	4275	4555	N/A	N/A	
	Gear Ratio Option 2	161.8	387.9	331	426	598	739	1309	N/A	N/A	N/A		
Weight (kg) - stroke = 150mm		49		91		209		610		620		1290	
Weight (kg) per extra 25mm		0.86		1.58		2.49		4.31		5.80		9.00	
Gear Ratio Option 1	Gear Ratio	8:1		10 2/3:1		10 2/3:1		12:1		11 2/3:1		18:1	
	Screw Jack Static Efficiency	0.161	0.246	0.128	0.198	0.113	0.184	0.112	0.096	0.093	0.093		
	Screw Jack Dynamic Efficiency	0.214	0.316	0.175	0.263	0.155	0.243	0.152	0.132	0.129			
Gear Ratio Option 2	Gear Ratio	24:1		32:1		32:1		36:1		N/A		N/A	
	Screw Jack Static Efficiency	0.098	0.150	0.072	0.112	0.067	0.108	0.068	N/A	N/A	N/A		
	Screw Jack Dynamic Efficiency	0.143	0.211	0.109	0.164	0.100	0.157	0.100	N/A	N/A			

**Note**

1. All metric machine screws have a trapezoidal thread form.
2. For loads of 25% to 100% of screw jack capacity, torque requirements are approximately proportional to the load.
3. Efficiency values for standard grease lubricated worm gear box and lifting screw.
4. All E-Series screw jacks have grease lubricated gearbox and lead screw as standard.

## Extra Safety for Critical Applications

Power Jacks machine screw jacks can be fitted with a safety nut, which provides 2 safety roles:

1. In the event of excessive wear on the nut thread the load will be transferred from the standard nut to the safety nut. This will also provide visual wear indication as the gap between the safety nut decreases to zero as the standard lifting nut wears.
2. In the unlikely event of catastrophic nut thread failure the safety nut will sustain the load. The safety of industrial and human cargo is therefore improved.

There are several configurations for each safety nut device as they only work in one load direction. For this reason when ordering please supply a sketch of your application showing load directions.

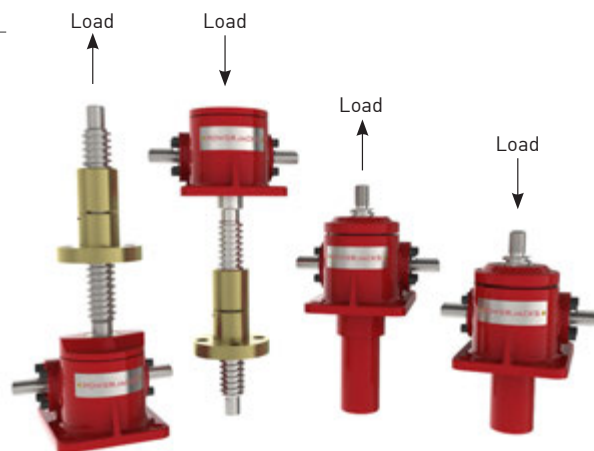

**All Safety Nuts are BS EN 1570 Compliant**

## Translating Screw Jacks with Safety Nuts

### Tension Safety Nut

### Compression Safety Nut

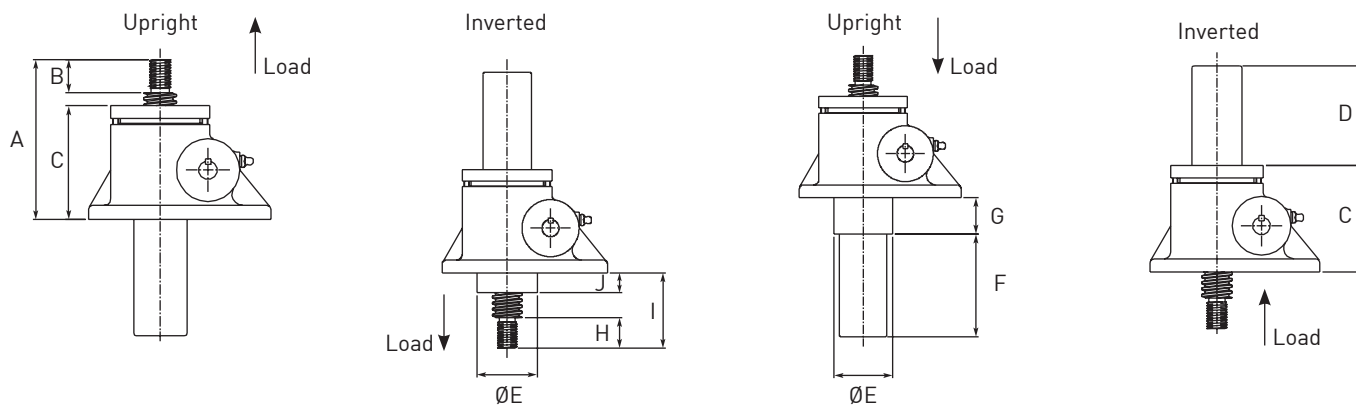

## Dimensions - Translating Screw

Model	Rating (kN)	A	B	C	D	ØE	F	G	H	I	J
EMT0005	5	On Request									
EMT0010	10	125	24	86	Stroke + 35	38	Stroke + 9	30	24	45	16
EMT0025	25	145	30	104	Stroke + 30	60	Stroke + 30	37	30	55	20
EMT0050	50	185	35	138	Stroke + 20	75	Stroke + 20	40	35	65	24
EMT0100	100	200	40	146	Stroke + 3	90	Stroke + 28	48	40	80	30
EMT0200	200	265	55	195	Stroke + 24	102	Stroke + 24	58	55	110	39
EMT0300	300	On Request									
EMT0500	500	On Request									
EMT1000	1000	On Request									
EMT1500	1500	On Request									
EMT2000	2000	On Request									

Rotating Screw Jacks with Safety Nuts

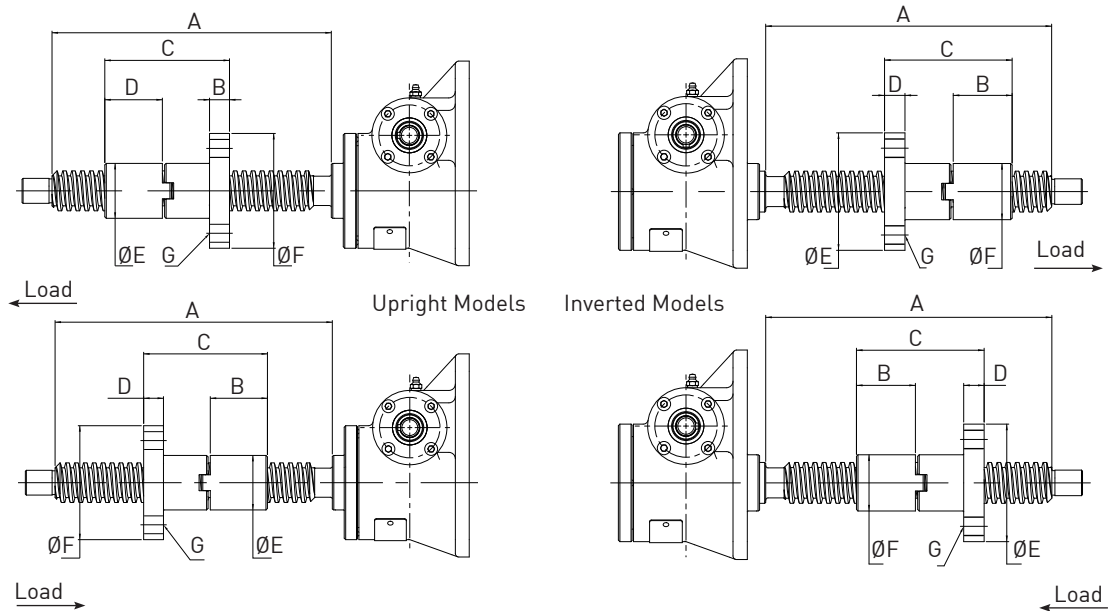

Dimensions - Rotating Screw

Model	Rating (kN)	A	B	C	D	ØE	ØF	G
EMR0005	5	On Request						
EMR0010	10	Stroke + 76	30	66.5	12	80	35	4 x Ø11, Ø57 PCD
EMR0025	25	Stroke + 95	33.5	75	15	90	40	4 x Ø13.5, Ø65 PCD
EMR0050	50	Stroke + 140	58	125	20	115	55	4 x Ø18, Ø85 PCD
EMR0100	100	Stroke + 170	67	145	25	160	80	4 x Ø22, Ø120 PCD
EMR0200	200	Stroke + 170	67	145	25	185	90	4 x Ø26, Ø135 PCD
EMR0300	300	Stroke + 310	126	270	35	230	125	6 x Ø26, Ø175 PCD
EMR0500	500	Stroke + 335	130	284	50	280	160	6 x Ø33, Ø220 PCD
EMR1000	1000	Stroke + 410	155	335	60	380	210	6 x Ø45, Ø295 PCD
EMR1500	1500	On Request						
EMR2000	2000	On Request						

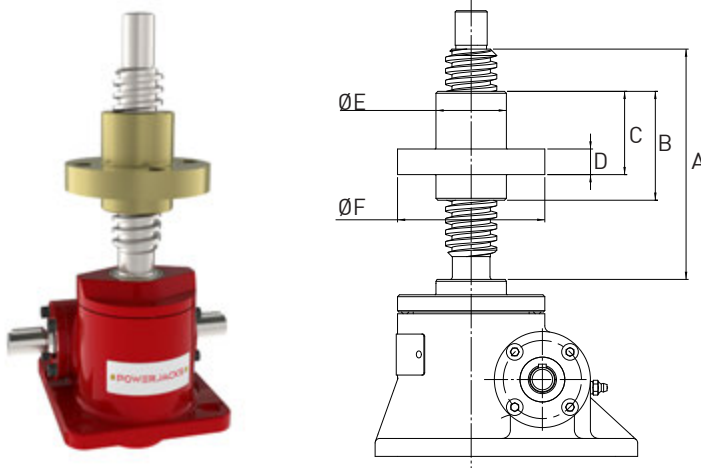

Model	A	B	C	D	ØE	F	ØG
EMR0010	Stroke + 55	40	25	10	25	4 x Ø9, Ø42 PCD	60
EMR0010	Stroke + 61	52	35	12	35	4 x Ø11, Ø57 PCD	80
EMR0025	Stroke + 80	60	40	15	40	4 x Ø13.5, Ø65 PCD	90
EMR0050	Stroke + 100	85	65	20	55	4 x Ø18, Ø85 PCD	115
EMR0100	Stroke + 120	95	75	25	80	4 x Ø22, Ø120 PCD	160
EMR0200	Stroke + 120	95	75	25	90	4 x Ø26, Ø135 PCD	185
EMR0300	Stroke + 200	160	140	35	125	6 x Ø26, Ø175 PCD	230
EMR0500	Stroke + 225	175	150	50	160	6 x Ø33, Ø220 PCD	280
EMR1000	Stroke + 275	200	175	60	210	6 x Ø45, Ø295 PCD	380
EMR1500	On Request						
EMR2000	On Request						

## Secondary Guide - Greater Lateral Rigidity for Lifting Screw

Secondary Guiding for the screw for greater lateral rigidity aiding screw guidance and improved side load resilience.

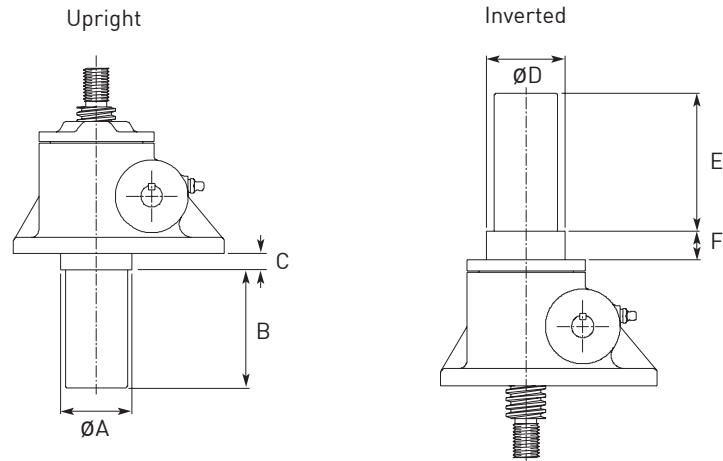

## Dimensions for Screw Jacks with Secondary Guides

Model	EMT0005	EMT0010	EMT0025	EMT0050	EMT0100	EMT0200	EMT0300	EMT0500	EMT1000	EMT1500	EMT2000	
Upright	ØA	36	38	60	70	90	100	138	155	225	On Request	On Request
	B	Stroke + 34	Stroke + 34	Stroke + 30	Stroke + 20	Stroke + 29	Stroke + 24	Stroke + 40	Stroke + 38	Stroke + 50		
	C	16	20	20	18	20	20	38	38	65		
Inverted	ØD	36	On Request	60	70	90	100	138	155	On Request	On Request	
	E	Stroke + 34	Stroke + 34	Stroke + 30	Stroke + 20	Stroke + 29	Stroke + 24	Stroke + 40	Stroke + 38			
	F	16	On Request	20	18	20	20	38	38			

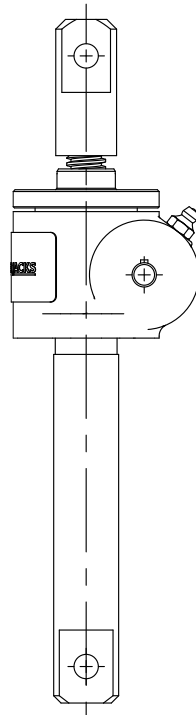

Style 1

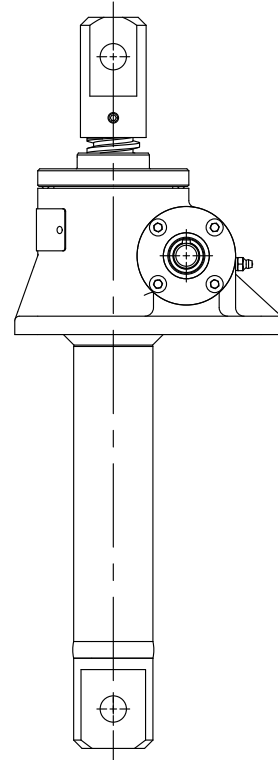

Style 2

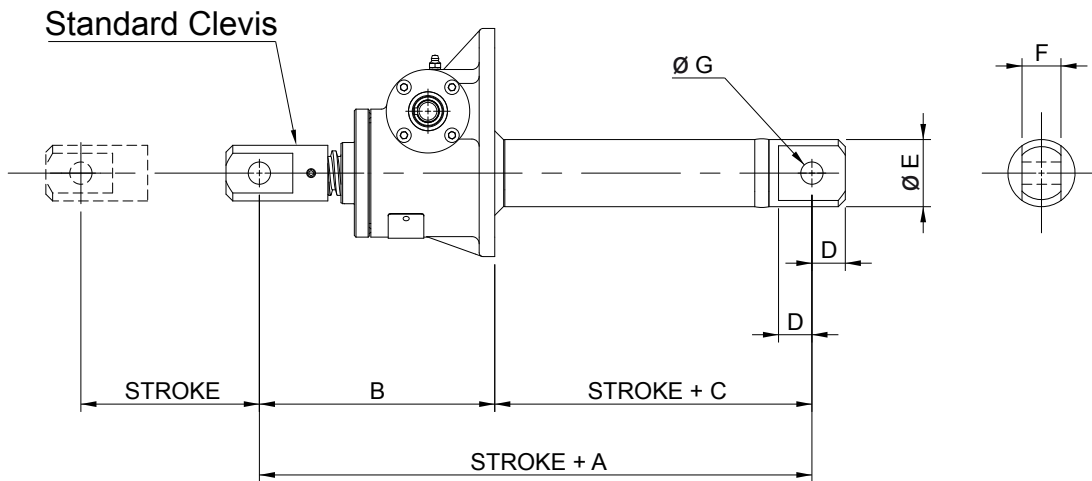

Model	EMT0005	EMT0010	EMT0025	EMT0050	EMT0100	EMT0200	EMT0300	EMT0500	EMT1000
Capacity [kN]	5	10	25	50	100	200	300	500	1000
Style	1	1	2	2	2	2	2	2	On Request
A	150	180	213	260	352	428	492	570	
B	115	145	170	210	247	313	367	440	
C	35	35	43	50	105	115	125	130	
D	15	20	23	30	33	40	60	75	
E	26.7	33.4	48.3	60.3	73	102	133	168	
F	15	20	30	35	40	50	80	110	
ØG	10	12	16	20	22	30	45	60	
Max Stroke at Rated Load [Compression]	220	175	352	420	593	592	1338	1920	

Note: All dimensions in millimetres unless otherwise stated.

E-Series

4

## E-Series Stainless Steel Screw Jacks

DESIGNED FOR USE IN  
HARSH & CORROSIVE  
ENVIRONMENTS  
CAPACITIES - 10KN TO  
1000KN AS STANDARD.

### TRANSLATING SCREW JACKS

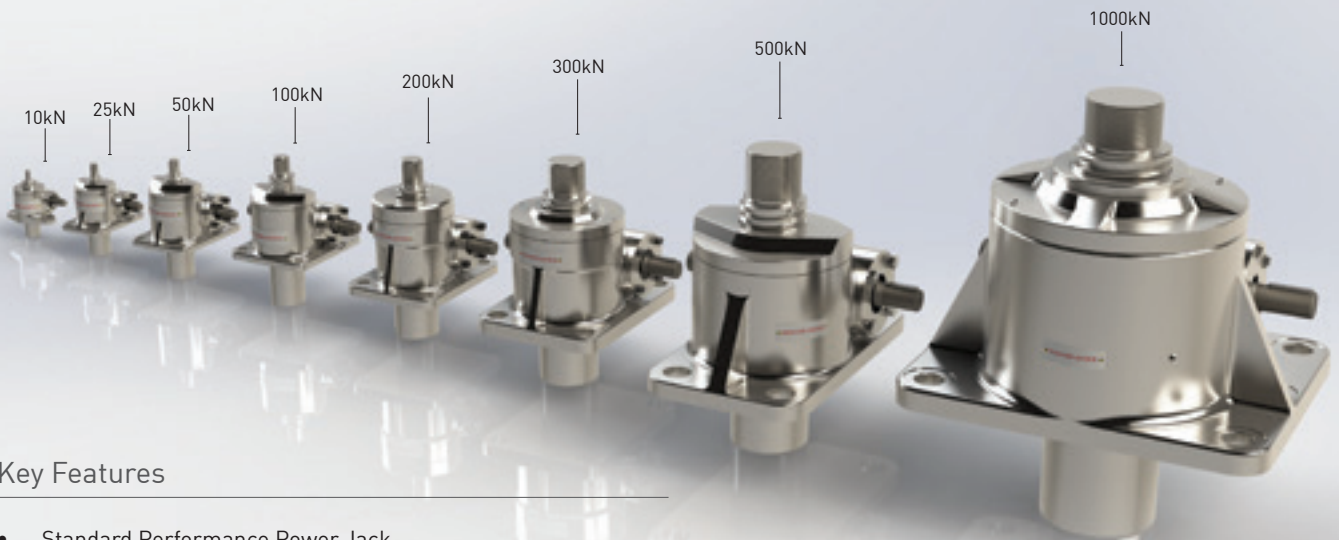

#### Key Features

- Standard Performance Power Jack
- Stainless Steel Machine Screw Jacks
- Capacities - 10kN to 1000kN as standard
- Translating and Rotating Screw in Upright and Inverted types
- Precision Worm Gear Set
- 2 Gear ratios and 1 screw lead as standard
- Anti-backlash and anti-rotation (keyed) options
- 6 mounting options including trunnion and double clevis
- Special custom designs available



### ROTATING SCREW JACKS



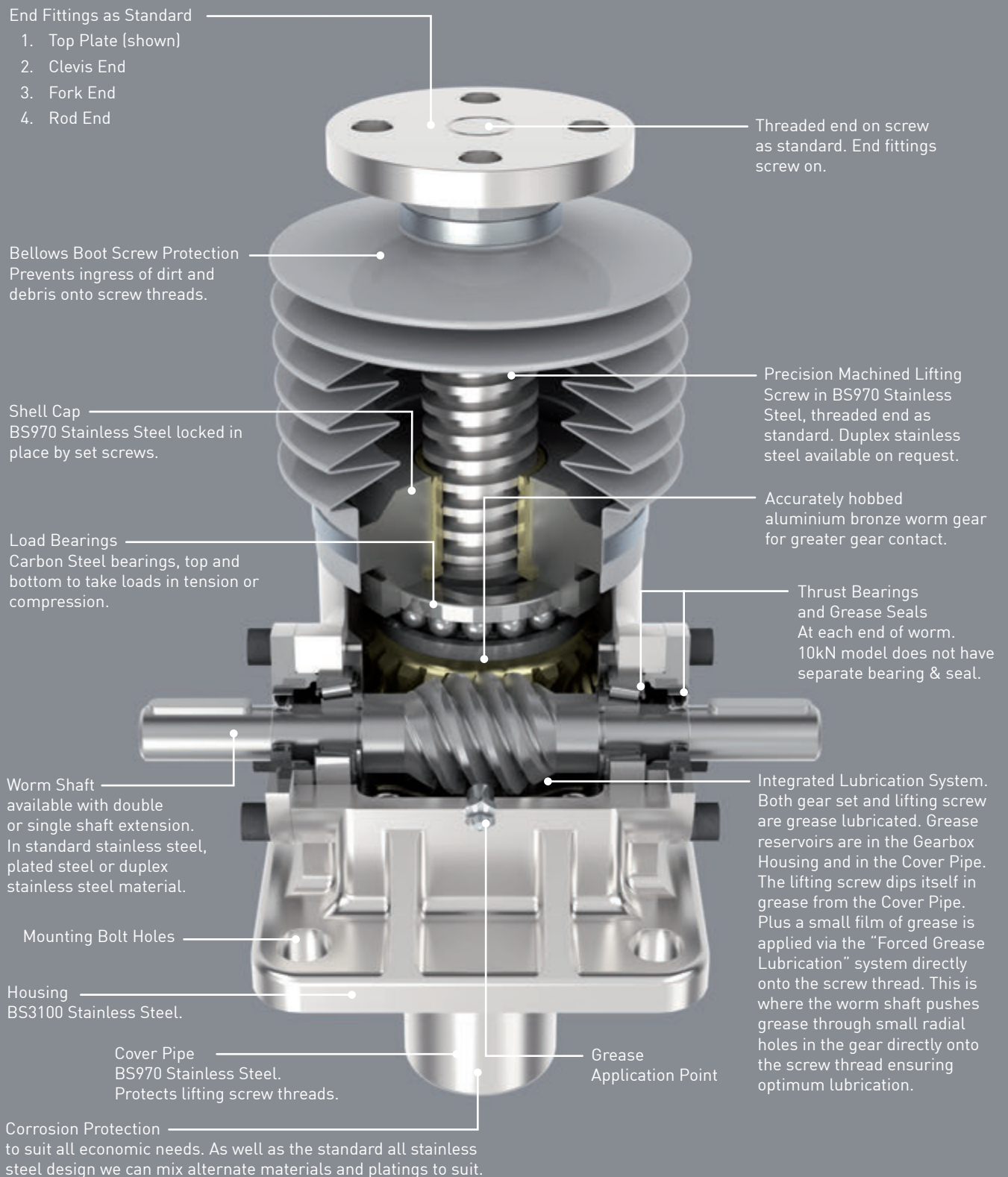

The stainless steel screw jacks are ideal for use in harsh or corrosive environments such as marine, nuclear, water, food processing or paper making machinery, where standard materials may be inadequate.

### Translating Screw



Upright



Inverted

### Rotating Screw



Upright



Inverted

## Typical Applications

Stainless Steel Machine Screw Jacks are typically used in harsh or corrosive environments or those with a regular wash down requirement. Industries such as Marine, Water Treatment, Nuclear, Food Processing, Offshore, Pulp and Paper use stainless steel screw jacks. For each application, variants with different material grades or plated components can be used, tailoring the product for the specific application and budget.

## Standard Designs

Stainless steel E-Series machine screw jacks are available in translating and rotating screw designs in capacity sizes from 10kN to 1000kN. The design is optimised for reliable performance in some of the most arduous environments. Plus there is a large selection of standard accessories (section-7) and options so you can configure a standard design that is just right for your application. These options include Anti-Backlash, Anti-Rotation (Keyed) and Safety Nut designs.

## Special Designs

We can fully customise our screw jacks so that your application can be the best.

Customisation can be anything from a small modification such as an extra bolt hole on an end fitting to a completely new design of screw jack based on our class leading technology.

For more details please see the Special Screw Jack information in Section-8 or contact us today with your requirements. Our team are looking forward to working with you.

## Selecting the Right Screw Jack

Consider all application constraints then choose a product that looks suitable for the intended application. Calculate the power and torque requirements. This is a 5 step process:

- Screw Jack Input Speed (RPM)
- Operating Input Power (kW)
- Operating Input Torque (Nm)
- Screw Jack Start-up Torque (Nm)
- Mechanical Power and Torque Check

## Systems

The screw jacks can be connected together in systems so that multiple units can be operated and controlled together. These jacking system arrangements or configurations can be built in many formats with the use of bevel gearboxes, motors, reduction gearbox, drive shafts, couplings, plummer blocks and motion control devices.

The use of bevel gearboxes allows the distribution of drive throughout a jacking system. The gearboxes come in 2,3 and 4 way drive types. See the Bevel Gearbox Section-10 for more details.

Bevel gearboxes and other system components can also be supplied in stainless steel or other corrosion resistant designs.



Two of the most popular system configurations are the 'H' and 'U' configured jacking systems. Remember that multiple screw jacks can be linked together mechanically or electrically. The latter is useful if there is no space for linking drive shafts.

If multiple machine screw jacks are connected in a mechanically linked system then the complete system may be considered self-locking. If you would like this checked consult Power Jacks. Alternatively, to be sure, include a brake on the system either as a stand alone device or as a brake motor.

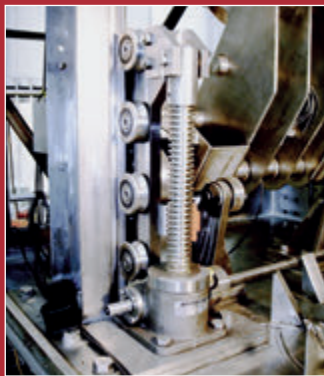

## DRUM POSTING EQUIPMENT (DPE)

Dunreay cementation plant waste transfer facility.

Raise and lower drum transfer table.

Two stainless steel E-Series translating machine screw jacks  
100kN capacity with 24:1 gear ratio and 1805mm stroke connected  
in series by a stainless steel drive shaft and geared couplings.

For more application examples see the 'Power at Work' brochure or [www.powerjacks.com](http://www.powerjacks.com).



## Stainless Steel Screw Jack Standard Performance

Model		EMT0010 EMR0010	EMT0025 EMR0025	EMT0050 EMR0050	EMT0100 EMR0100	EMT0200 EMR0200	EMT0300 EMR0300	EMT0500 EMR0500	EMT1000 EMR1000	
Capacity	kN	10	25	50	100	200	300	500	1000	
Sustaining Capacity (kN)	Standard 316 Lifting Screw	Tension	6.6	16.5	33	66	132	200	333	666
		Compression	10	25	50	100	200	300	500	1000
	Duplex Lifting Screw	10	25	50	100	200	300	500	1000	
Operating Capacity (kN)	Stainless Steel Worm Shaft		3.3	8.25	16.5	33	66	100	167	333
	Duplex or Plated Worm Shaft with 316 Screw	Tension	6.6	16.5	33	66	132	200	333	666
		Compression	10	25	50	100	200	300	500	1000
Duplex or Plated Worm Shaft with Duplex Screw		10	25	50	100	200	300	500	1000	
Lifting Screw	Diameter (mm)	20	30	40	55	65	95	120	160	
	Lead (mm)	5	6	9	12	12	16	16	20	
Gear ratios	Option 1	5:1	6:1	6:1	8:1	8:1	10 2/3	10 2/3:1	12:1	
	Option 2	20:1	24:1	24:1	24:1	24:1	32:1	32:1	36:1	
Turn of worm for travel of lifting screw	Ratio Option 1	1 Turn	1mm	1mm	1.5mm	1.5mm	1.5mm	1.5mm	1.67mm	
	Ratio Option 2	4 Turn	1mm	1mm	1.5mm	2mm	2mm	2mm	2.22mm	
Max. Input power (kW)	Gear Ratio Option 1	0.375	1.5	3.0	3.75	3.75	6.0	11.25	18.5	
	Gear Ratio Option 2	0.19	0.375	0.55	1.125	1.125	1.9	4.5	8.25	
Start up torque at full load (Nm)	Gear Ratio Option 1	6.8	19.8	56	115.9	263.8	480	904	2025	
	Gear Ratio Option 2	3	8.7	25.5	60.5	137	284	504	1119	
Weight (kg) - stroke = 150mm	EMT	2.36	8.45	14.9	24.3	42.4	92.4	183.7	459.1	
	EMR	2.6	8.85	16.54	28.8	49.58	113.78	224	560.4	
Weight (kg) per extra 25mm	EMT	0.11	0.21	0.32	0.58	0.84	1.55	2.48	4.11	
	EMR	0.05	0.11	0.19	0.36	0.52	1.13	1.94	3.38	
Gear Ratio Option 1	Gear Ratio	5:1	6:1	6:1	8:1	8:1	10 2/3:1	10 2/3:1	12:1	
	Screw Jack Static Efficiency	0.233	0.201	0.213	0.206	0.181	0.149	0.132	0.131	
	Screw Jack Dynamic Efficiency	0.306	0.264	0.281	0.272	0.242	0.205	0.181	0.178	
Gear Ratio Option 2	Gear Ratio	20:1	24:1	24:1	24:1	24:1	32:1	32:1	36:1	
	Screw Jack Static Efficiency	0.130	0.115	0.117	0.132	0.116	0.084	0.079	0.079	
	Screw Jack Dynamic Efficiency	0.194	0.167	0.172	0.190	0.169	0.128	0.120	0.123	

## Notes

- All metric stainless steel machine screws have a trapezoidal thread form, single start as standard. Other screw lead options are available on request.
- Based on operating capacity for loads of 25% to 100% of screw jack capacity, torque requirements are approximately proportional to the load.
- Efficiency values for standard grease lubricated worm gear box and lifting screw

## Upright EMT0010-V00

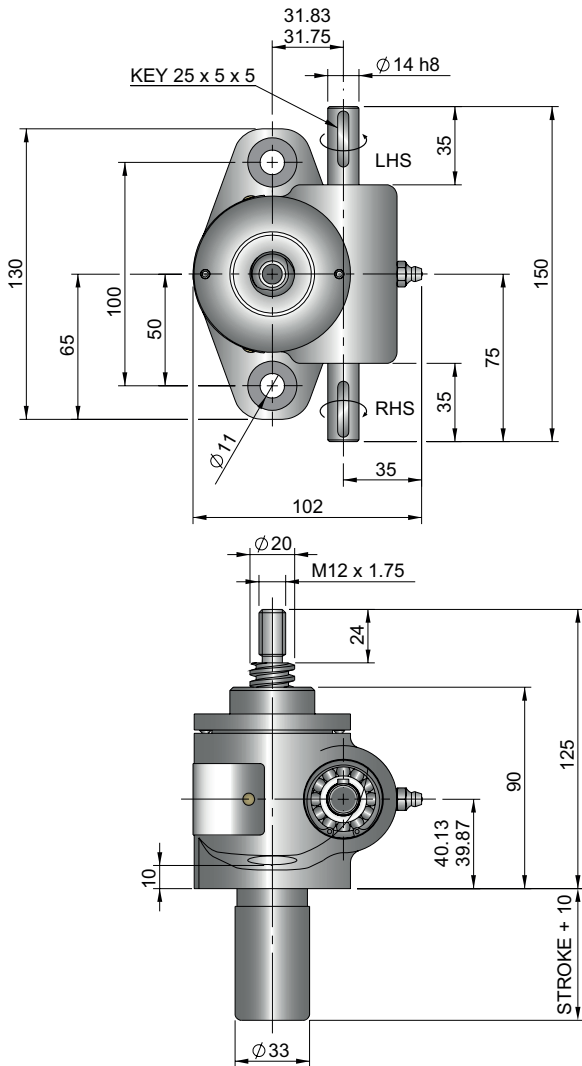

## Inverted EMT0010-J00

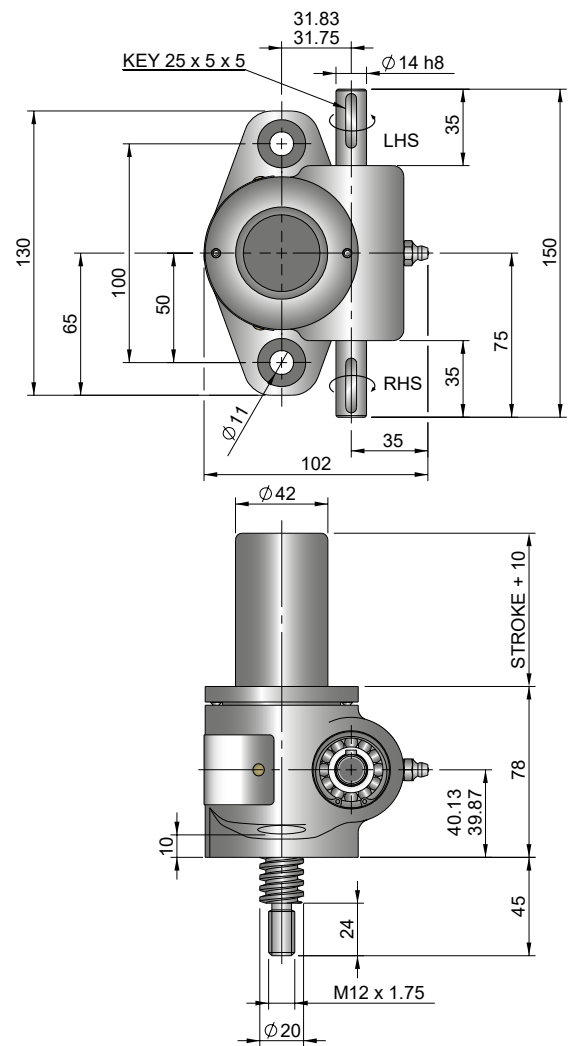

## Performance

Model			EMT0010 EMR0010	
Capacity (kN)			10	
Sustaining Capacity (kN)	Standard 316 Lifting Screw	Tension	6.6	
		Compression	10	
Duplex Lifting Screw			10	
Operating Capacity (kN)	Standard 316 Worm Shaft		3.3	
	Duplex or Plated Worm Shaft with 316 Screw	Tension	6.6	
		Compression	10	
Duplex or Plated Worm Shaft with Duplex Screw			10	
Lifting Screw	Diameter (mm)		20	
	Lead	Option	1	2
mm		5	10	
Gear Ratio Option 1	Gear Ratio		5:1	
	Screw Jack Static Efficiency		0.233	0.339
	Screw Jack Dynamic Efficiency		0.306	0.424
Gear Ratio Option 2	Gear Ratio		20:1	
	Screw Jack Static Efficiency		0.130	0.192
	Screw Jack Dynamic Efficiency		0.194	0.268

Model			EMT0010 EMR0010	
Capacity	kN		10	
Lifting Screw Lead (mm)			5	10
Turn of worm for travel of lifting screw	Gear Ratio 1	1 Turn	1mm	2mm
	Gear Ratio 2	4 Turn	1mm	2mm
Maximum Through Torque (Nm)			20	
Lifting Screw Restraining Torque (Nm)			22	30
Worm Shaft Maximum Radial Load (N)			325	
Maximum Input Speed (rpm)			1800	
Gear Case Material			Stainless Steel	
Weight (kg) - stroke = 150mm			EMT	2.36
			EMR	2.6
Weight (kg) - per extra 25mm stroke			EMT	0.11
			EMR	0.05

Note: All dimension in millimetres unless otherwise stated.  
Designs subject to change without notice

## Closed Height

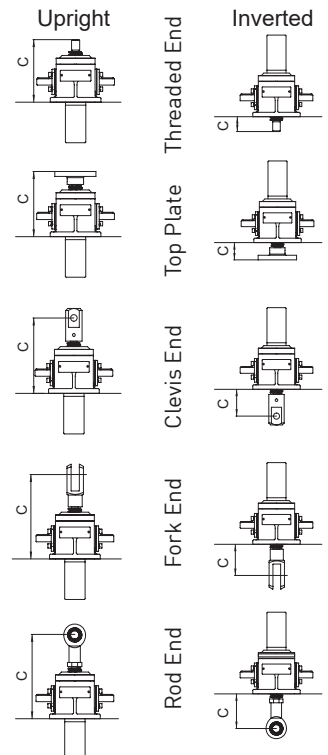



## Upright EMR0010-V00

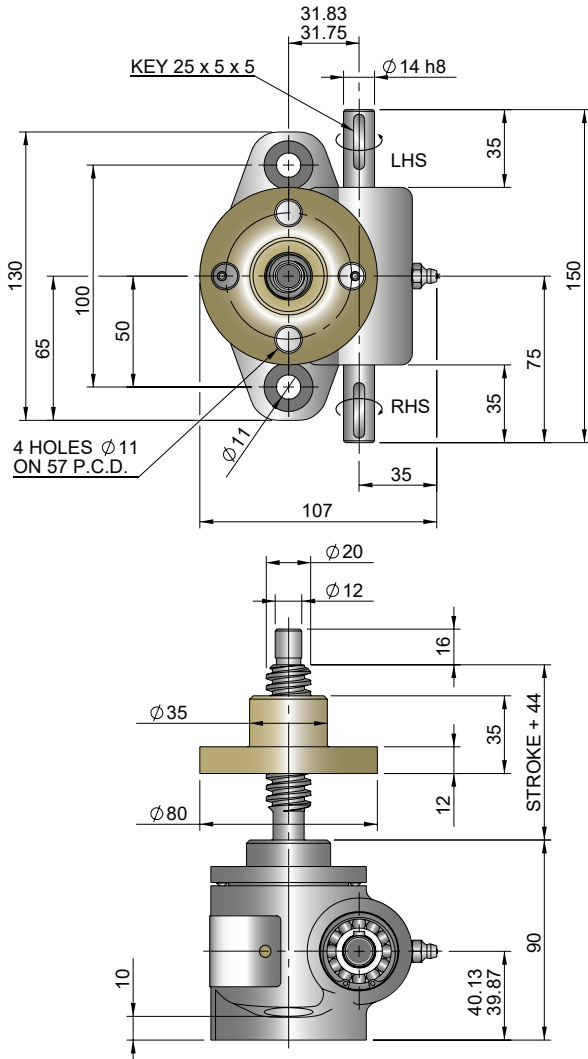

## Inverted EMR0010-J00

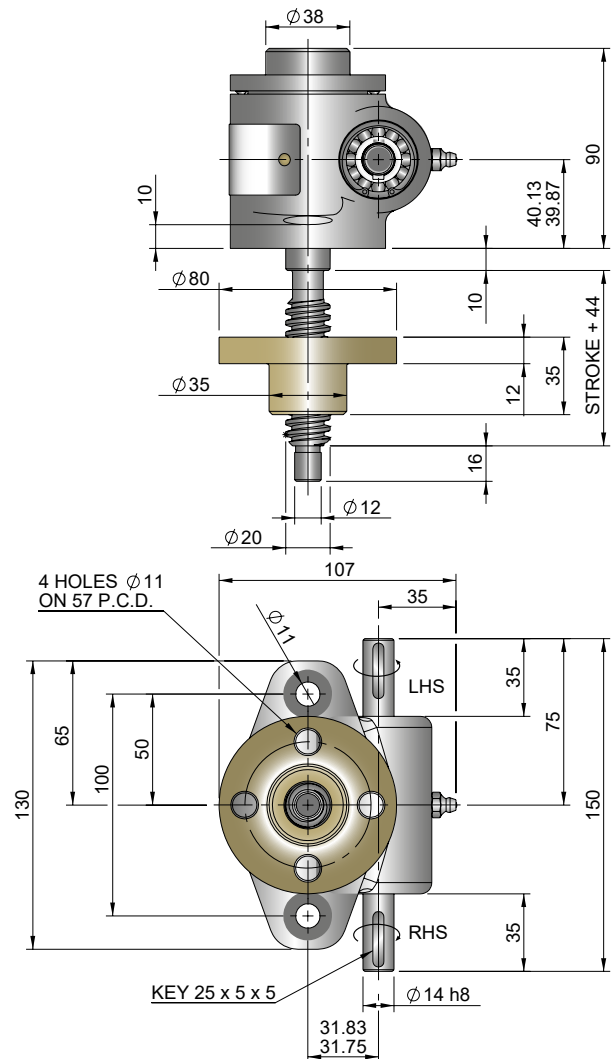

## Closed Height & Bellows Boots

Closed Height "C"	Threaded End		Top Plate		Clevis End		Fork End		Rod End	
	Upright	Inverted	Upright	Inverted	Upright	Inverted	Upright	Inverted	Upright	Inverted
EMT0010	125	45	125	45	145	65	148	98	150	70
Stroke (mm)	EMT0010 with Bellows Boots									
0-150	125	75	125	75	145	95	148	98	165	115
151-300	130	95	130	95	150	115	153	118	170	135
301-600	140	95	140	95	160	115	163	118	180	135
751-1000	-	-	-	-	-	-	-	-	-	-

Model	A	B	D	E	G
EMT0010	30	70	15	15	110

Stroke	1-150	151-300	301-600	601-900	901-1050
EMT0010	8	20	35	-	-

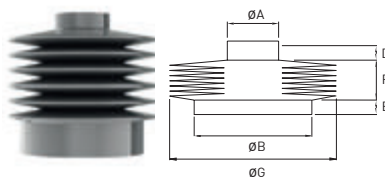

## Column Strength

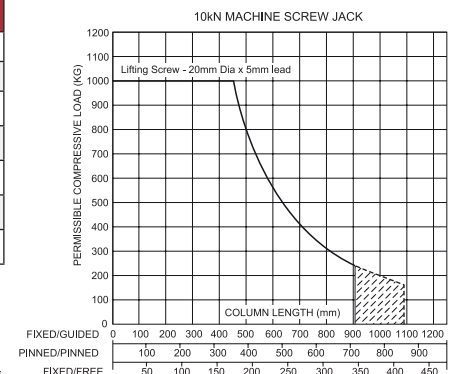

Note:

- 1 Inverted Screw Jacks - Bellows Boot Closed Height assumes screw jack mounted on a structure with thickness = 15mm
- 2 Inverted Screw Jacks - Recommended bellows boot mounting plate  $\varnothing B \times [E + 5\text{mm}]$  thick.
- 3 Inverted Screw Jacks - Screw Jack mounting plate & bellows boot mounting plate are customers own supply
- 4 † Control tapes fitted (increase outer diameter by 20mm approximately).
- 5 For horizontal installations with than 450 mm of stroke, internal boot guides are recommended.
- 6 Customers with threaded end screw jacks must provide a fixing for the unattached bellows boot collar.
- 7 Bellows boots for Rotating Screw Jacks, other sizes, stroke and materials please consult Power Jacks.

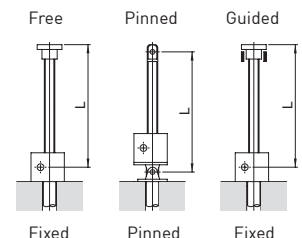

## Upright EMT0025-V00

## Inverted EMT0025-J00

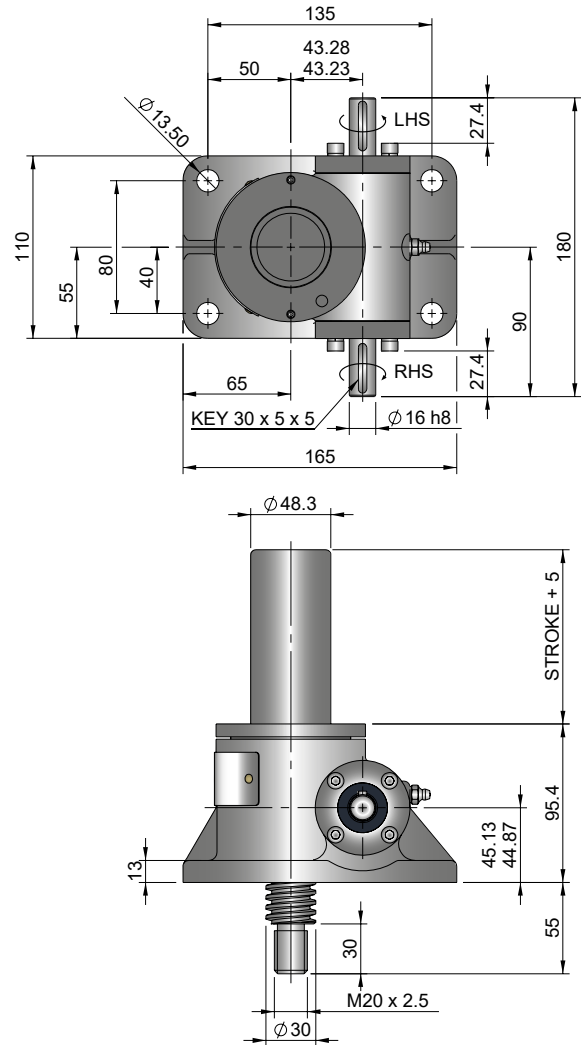
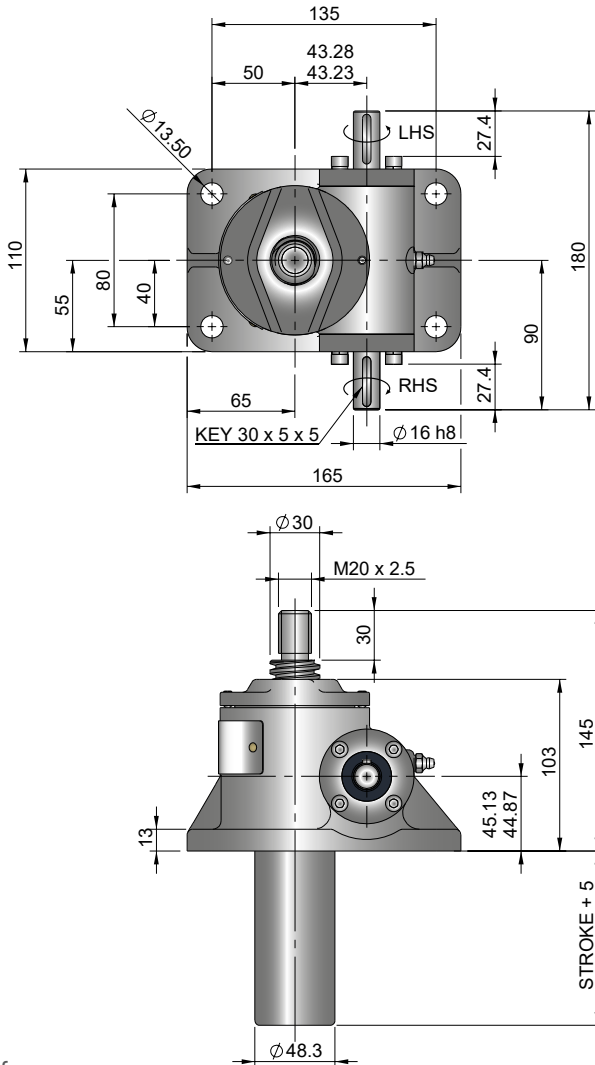

## Performance

## Closed Height

Model		EMT0025 EMR0025	
Capacity (kN)		25	
Sustaining Capacity (kN)	Standard 316 Lifting Screw	Tension	16.5
		Compression	25
Duplex Lifting Screw		25	
Operating Capacity (kN)	Standard 316 Worm Shaft		8.25
	Duplex or Plated Worm Shaft with 316 Screw	Tension	16.5
		Compression	59
Duplex or Plated Worm Shaft with Duplex Screw		25	
Lifting Screw	Diameter (mm)		30
	Lead	Option	1   2
		mm	6   12
Gear Ratio Option 1	Gear Ratio		6:1
	Screw Jack Static Efficiency		0.201   0.302
	Screw Jack Dynamic Efficiency		0.264   0.383
Gear Ratio Option 2	Gear Ratio		24:1
	Screw Jack Static Efficiency		0.115   0.171
	Screw Jack Dynamic Efficiency		0.167   0.242

Model		EMT0025 EMR0025	
Capacity	kN		25
Lifting Screw Lead (mm)			6   12
Turn of worm for travel of lifting screw	Gear Ratio 1	1 Turn	1mm   2mm
	Gear Ratio 2	4 Turn	1mm   2mm
Maximum Through Torque (Nm)		59	
Lifting Screw Restraining Torque (Nm)		76	102
Worm Shaft Maximum Radial Load (N)		380	
Maximum Input Speed (rpm)		1800	
Gear Case Material		Stainless Steel	
Weight (kg) - stroke = 150mm		EMT	8.45
		EMR	8.85
Weight (kg) - per extra 25mm stroke		EMT	0.21
		EMR	0.11

Note: All dimension in millimetres unless otherwise stated.  
Designs subject to change without notice

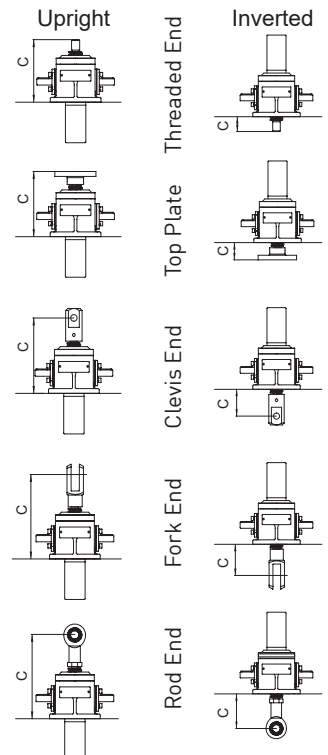



## Upright EMR0025-V00

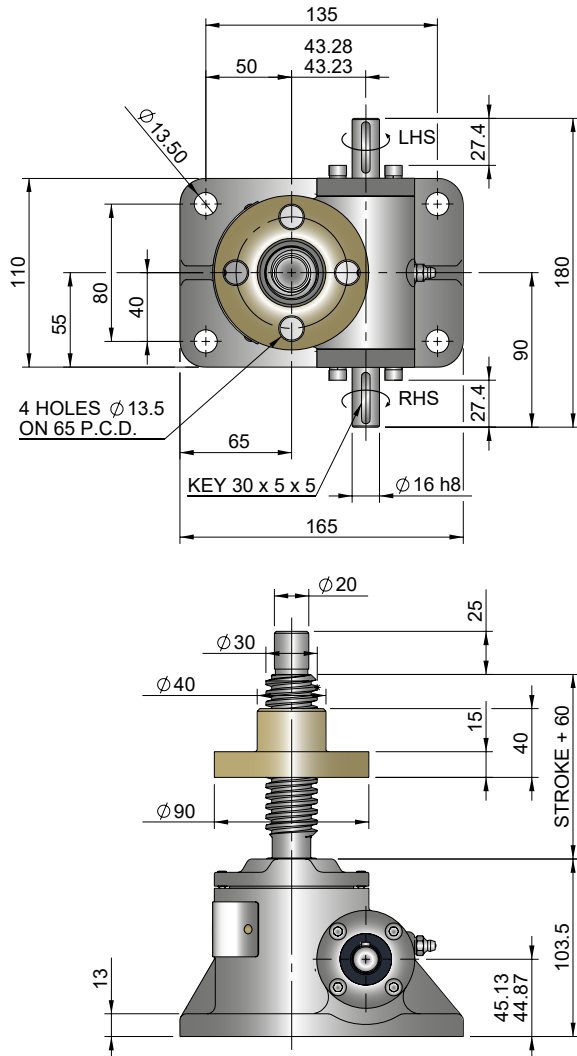

## Inverted EMR0025-J00

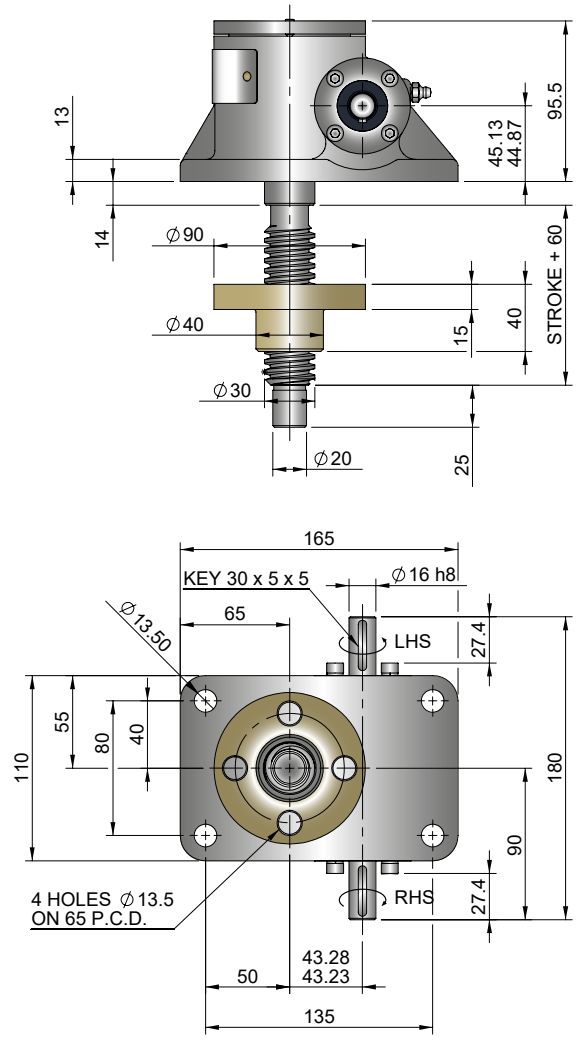

## Closed Height & Bellows Boots

Closed Height "C"	Threaded End		Top Plate		Clevis End		Fork End		Rod End	
	Upright	Inverted	Upright	Inverted	Upright	Inverted	Upright	Inverted	Upright	Inverted
EMT0025	145	55	145	55	170	80	194	104	190	100
Stroke (mm)	EMT0025 with Bellows Boots									
1-300	145	80	145	80	170	105	194	129	205	140
301-600	145	80	145	80	170	105	194	129	205	140
601-1050	170	105	170	105	195	130	219	154	230	165
1051-1500	195	130	195	130	220	155	244	179	255	190

Model	A	B	D	E	G
EMT0025	40	90	15	23	120

Stroke	1-150	151-301	301-600	601-1050	1051-1500
EMT0025	8	20	30	50	70

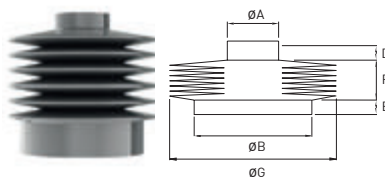

## Column Strength

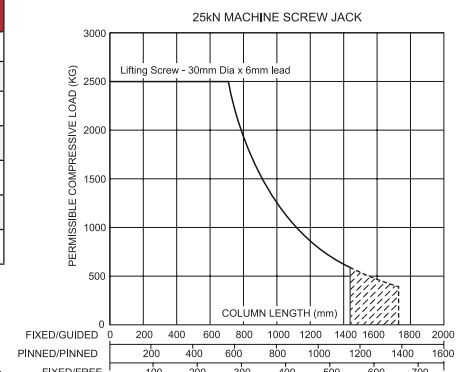

Note:

- Inverted Screw Jacks - Bellows Boot Closed Height assumes screw jack mounted on a structure with thickness = 15mm
- Inverted Screw Jacks - Recommended bellows boot mounting plate  $\varnothing B \times [E + 5\text{mm}]$  thick.
- Inverted Screw Jacks - Screw Jack mounting plate & bellows boot mounting plate are customers own supply
- † Control tapes fitted (increase outer diameter by 20mm approximately).
- For horizontal installations with than 450 mm of stroke, internal boot guides are recommended.
- Customers with threaded end screw jacks must provide a fixing for the unattached bellows boot collar.
- Bellows boots for Rotating Screw Jacks, other sizes, stroke and materials please consult Power Jacks.

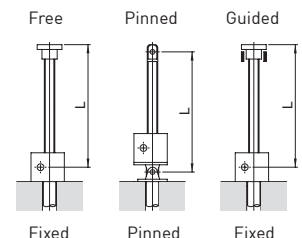

## Upright EMT0050-V00

## Inverted EMT0050-J00

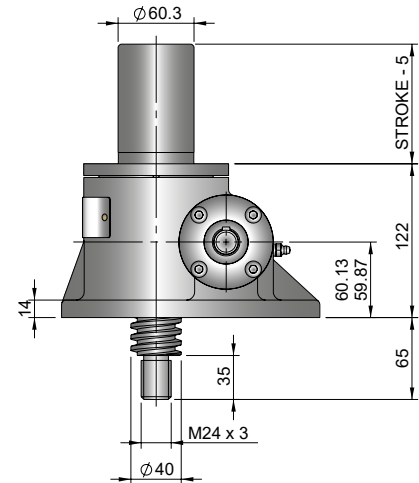
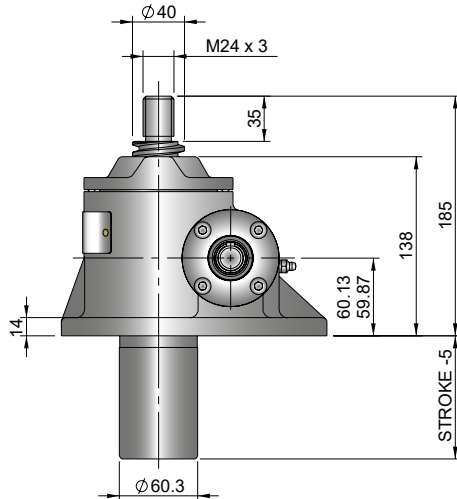
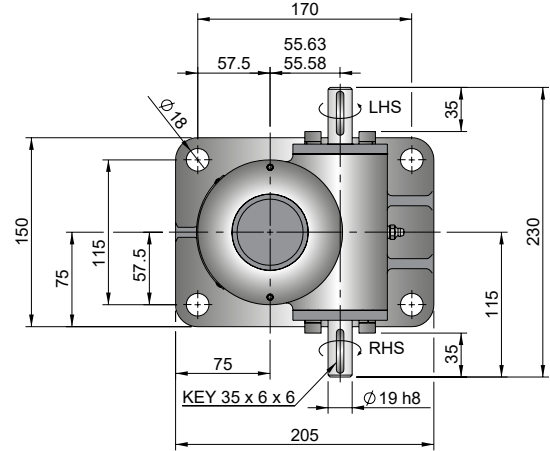
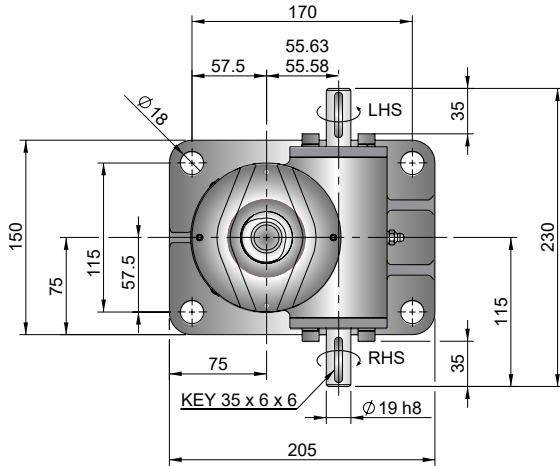

## Performance

## Closed Height

Model		EMT0050 EMR0050	
Capacity (kN)		50	
Sustaining Capacity (kN)	Standard 316 Lifting Screw	Tension	33
		Compression	33
Duplex Lifting Screw		50	
Operating Capacity (kN)	Standard 316 Worm Shaft		16.5
	Duplex or Plated Worm Shaft with 316 Screw	Tension	33
		Compression	50
Duplex or Plated Worm Shaft with Duplex Screw		50	
Lifting Screw	Diameter (mm)		40
	Lead	Option	1   2
		mm	9   18
Gear Ratio Option 1	Gear Ratio		6:1
	Screw Jack Static Efficiency		0.213   0.314
	Screw Jack Dynamic Efficiency		0.281   0.398
Gear Ratio Option 2	Gear Ratio		24:1
	Screw Jack Static Efficiency		0.117   0.172
	Screw Jack Dynamic Efficiency		0.172   0.244

Model		EMT0050 EMR0050	
Capacity	kN	50	
Lifting Screw Lead (mm)		9	18
Turn of worm for travel of lifting screw	Gear Ratio 1	1 Turn	1.5mm   3mm
	Gear Ratio 2	4 Turn	1.5mm   3mm
Maximum Through Torque (Nm)		168	
Lifting Screw Restraining Torque (Nm)		210	290
Worm Shaft Maximum Radial Load (N)		740	
Maximum Input Speed (rpm)		1800	
Gear Case Material		Stainless Steel	
Weight (kg) - stroke = 150mm		EMT	14.9
		EMR	16.54
Weight (kg) - per extra 25mm stroke		EMT	0.32
		EMR	0.19

Note: All dimension in millimetres unless otherwise stated.  
Designs subject to change without notice

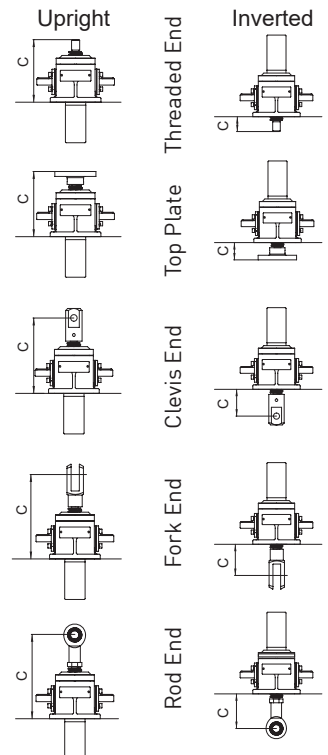

## Upright EMR0050-V00

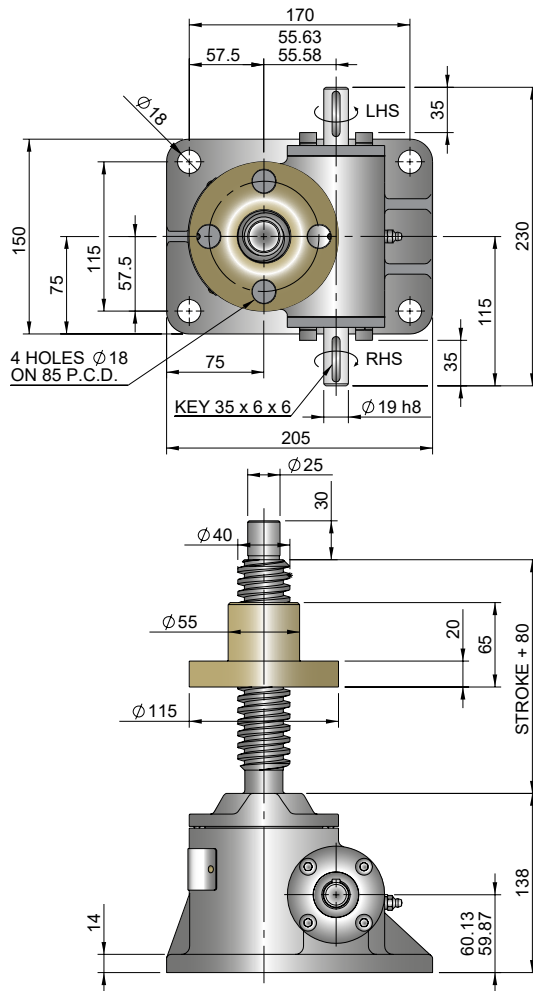

## Inverted EMR0050-J00

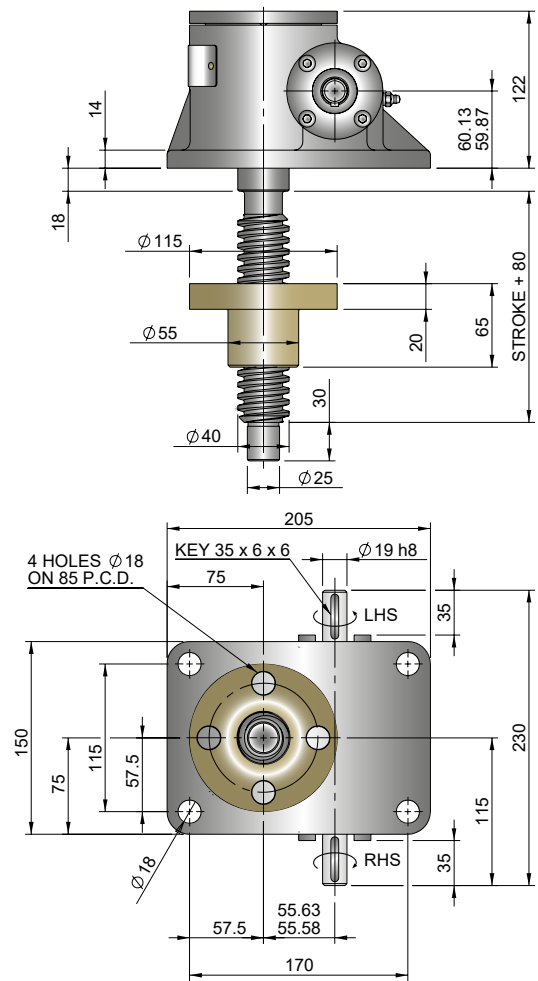

## Closed Height & Bellows Boots

Closed Height "C"	Threaded End		Top Plate		Clevis End		Fork End		Rod End	
	Upright	Inverted	Upright	Inverted	Upright	Inverted	Upright	Inverted	Upright	Inverted
EMT0050	185	65	185	65	210	90	248	128	242	122
Stroke (mm)	EMT0050 with Bellows Boots									
1-150	185	110	185	110	210	135	248	173	257	182
151-300	185	120	185	120	210	145	248	183	257	192
301-600	210	130	210	130	235	155	273	193	282	202
601-1050	210	150	210	150	235	175	273	213	282	222
1051-1500	235	170	235	170	260	195	298	233	307	242

Model	A	B	D	E	G
EMT0050	50	115	15	31	140

Stroke	1-150	151-300	301-600	601-1050	1051-1500
EMT0050	8	20	30	50	70

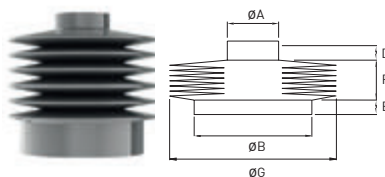

## Column Strength

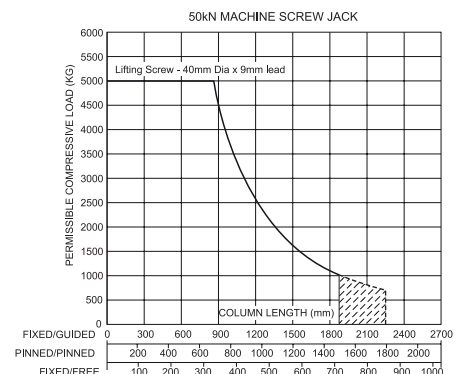

Note:

- 1 Inverted Screw Jacks - Bellows Boot Closed Height assumes screw jack mounted on a structure with thickness = 15mm
- 2 Inverted Screw Jacks - Recommended bellows boot mounting plate  $\varnothing B \times [E + 5mm]$  thick.
- 3 Inverted Screw Jacks - Screw Jack mounting plate & bellows boot mounting plate are customers own supply
- 4 † Control tapes fitted (increase outer diameter by 20mm approximately).
- 5 For horizontal installations with than 450 mm of stroke, internal boot guides are recommended.
- 6 Customers with threaded end screw jacks must provide a fixing for the unattached bellows boot collar.
- 7 Bellows boots for Rotating Screw Jacks, other sizes, stroke and materials please consult Power Jacks.

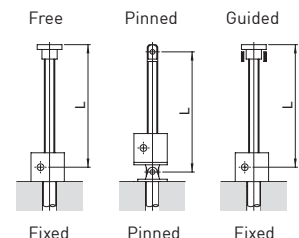

## Upright EMT0100-V00

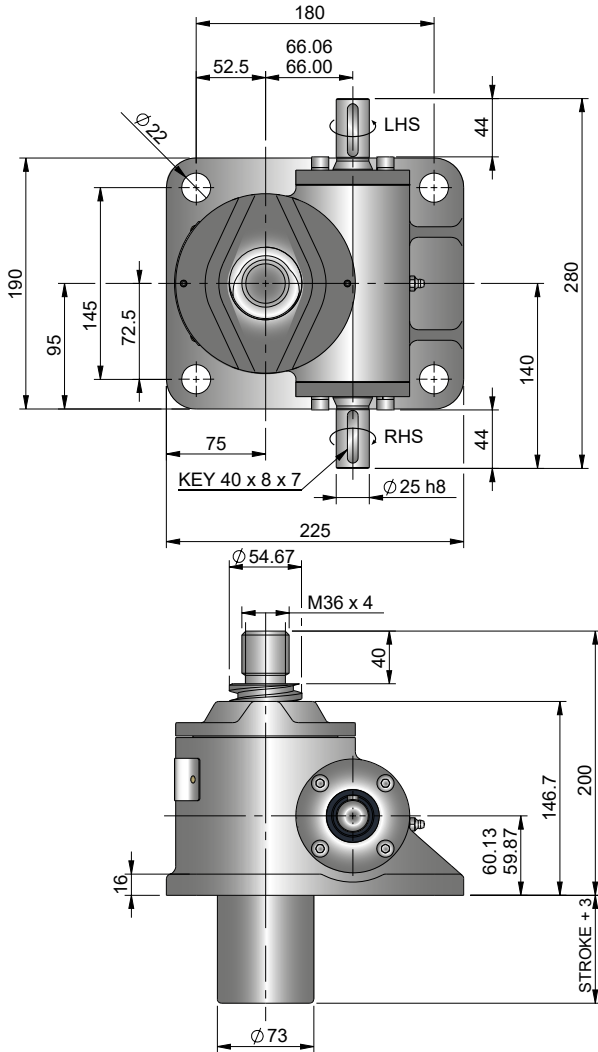

## Inverted EMT0100-J00

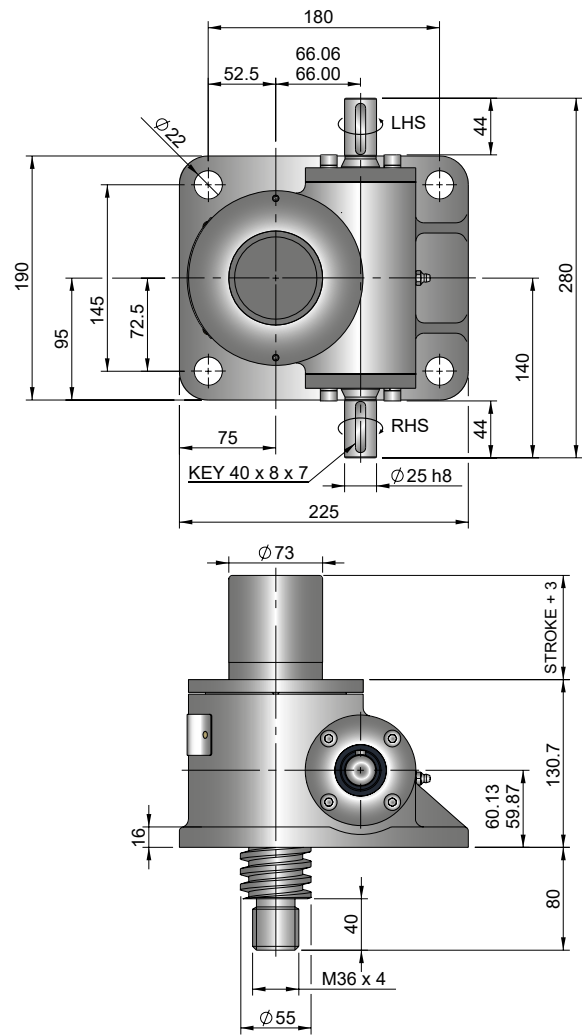

## Performance

Model		EMT0100 EMR0100	
Capacity (kN)		100	
Sustaining Capacity (kN)	Standard 316 Lifting Screw	Tension	66
		Compression	100
Duplex Lifting Screw		100	
Operating Capacity (kN)	Standard 316 Worm Shaft		33
	Duplex or Plated Worm Shaft with 316 Screw	Tension	66
		Compression	100
Duplex or Plated Worm Shaft with Duplex Screw		100	
Lifting Screw	Diameter (mm)		55
	Lead	Option	1   2
		mm	12   24
Gear Ratio Option 1	Gear Ratio		8:1
	Screw Jack Static Efficiency		0.206   0.305
	Screw Jack Dynamic Efficiency		0.272   0.388
Gear Ratio Option 2	Gear Ratio		24:1
	Screw Jack Static Efficiency		0.132   0.195
	Screw Jack Dynamic Efficiency		0.190   0.271

Model		EMT0100 EMR0100	
Capacity	kN	100	
Lifting Screw Lead (mm)		12	24
Turn of worm for travel of lifting screw	Gear Ratio 1	1 Turn	1.5mm   3mm
	Gear Ratio 2	4 Turn	2mm   4mm
Maximum Through Torque (Nm)		347	
Lifting Screw Restraining Torque (Nm)		575	780
Worm Shaft Maximum Radial Load (N)		1000	
Maximum Input Speed (rpm)		1800	
Gear Case Material		Stainless Steel	
Weight (kg) - stroke = 150mm		EMT	24.3
		EMR	28.8
Weight (kg) - per extra 25mm stroke		EMT	0.58
		EMR	0.36

Note: All dimension in millimetres unless otherwise stated. Designs subject to change without notice

## Closed Height

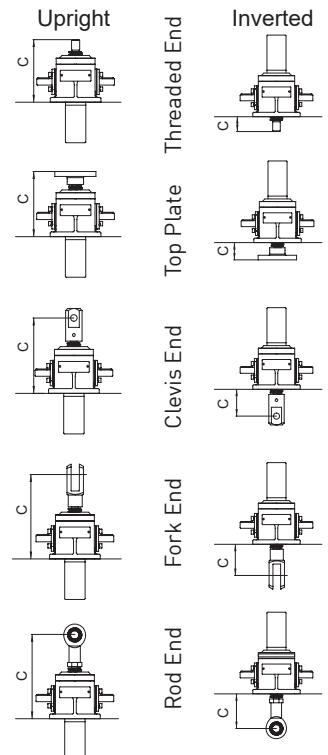



## Upright EMT0200-V00

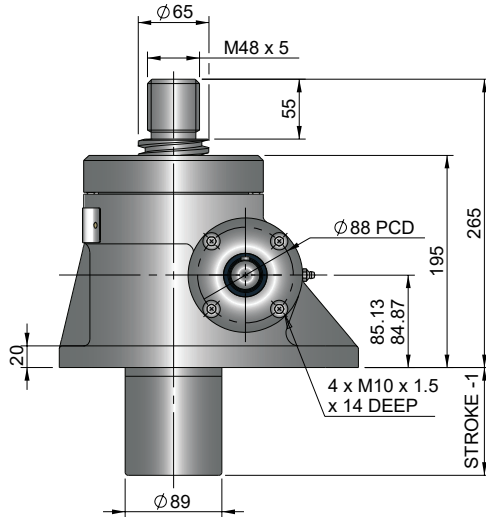
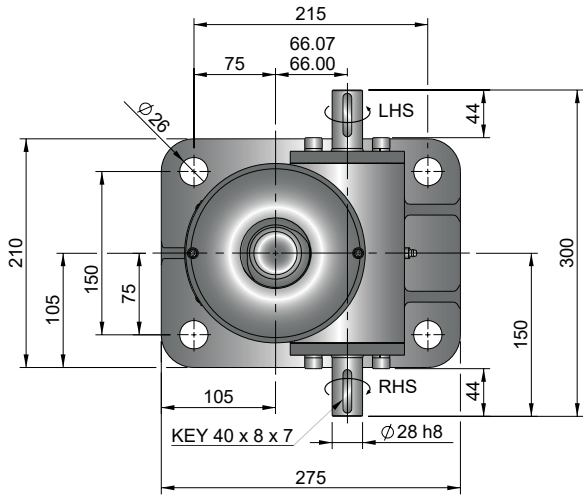

## Inverted EMT0200-J00

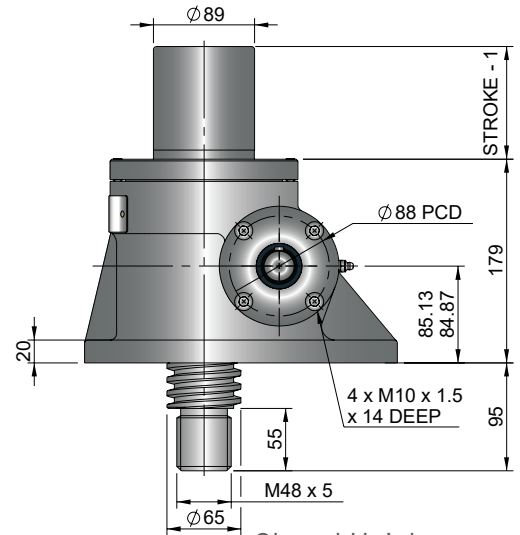
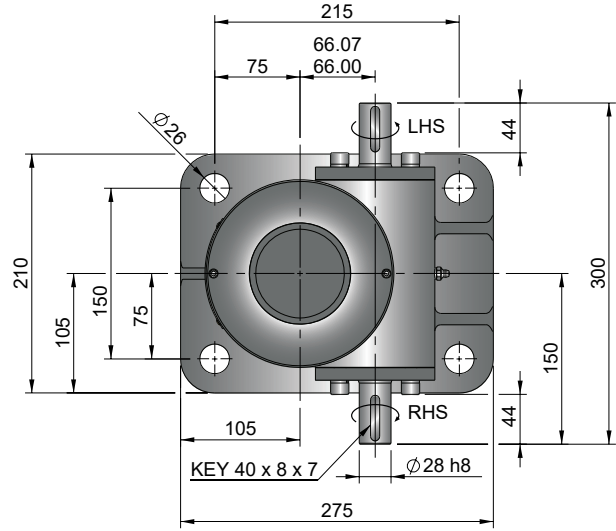

## Performance

Model		EMT0200 EMR0200	
Capacity (kN)		200	
Sustaining Capacity (kN)	Standard 316 Lifting Screw	Tension	132
		Compression	200
Duplex Lifting Screw		200	
Operating Capacity (kN)	Standard 316 Worm Shaft		66
	Duplex or Plated Worm Shaft with 316 Screw	Tension	132
		Compression	200
Duplex or Plated Worm Shaft with Duplex Screw		200	
Lifting Screw	Diameter (mm)		65
	Lead	Option	1   2
		mm	12   24
Gear Ratio Option 1	Gear Ratio		8:1
	Screw Jack Static Efficiency		0.181   0.279
	Screw Jack Dynamic Efficiency		0.242   0.357
Gear Ratio Option 2	Gear Ratio		24:1
	Screw Jack Static Efficiency		0.116   0.178
	Screw Jack Dynamic Efficiency		0.169   0.250

Model		EMT0200 EMR0200	
Capacity	kN		200
Lifting Screw Lead (mm)			12   24
Turn of worm for travel of lifting screw	Gear Ratio 1	1 Turn	1.5mm   3mm
	Gear Ratio 2	4 Turn	2mm   4mm
Maximum Through Torque (Nm)		396	
Lifting Screw Restraining Torque (Nm)		1300	1705
Worm Shaft Maximum Radial Load (N)		1600	
Maximum Input Speed (rpm)		1800	
Gear Case Material		Stainless Steel	
Weight (kg) - stroke = 150mm		EMT	42.4
		EMR	49.58
Weight (kg) - per extra 25mm stroke		EMT	0.84
		EMR	0.52

Note: All dimension in millimetres unless otherwise stated.  
Designs subject to change without notice

## Closed Height

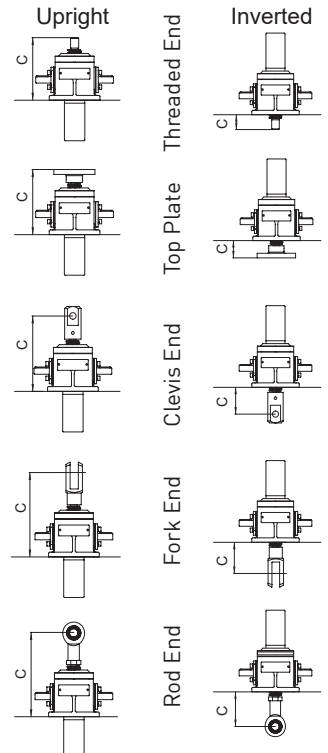

## Upright EMR0200-V00

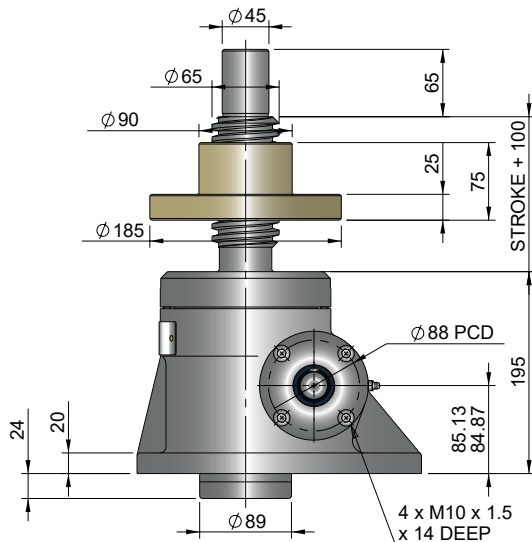
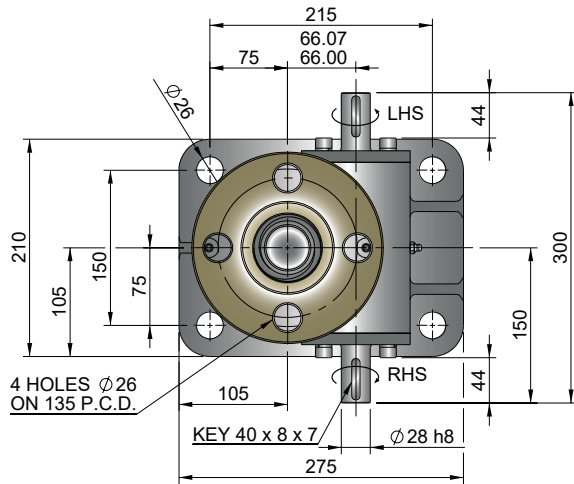

## Inverted EMR0200-J00

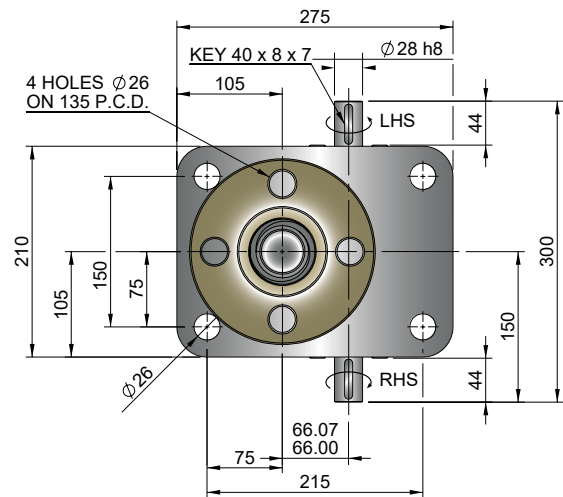
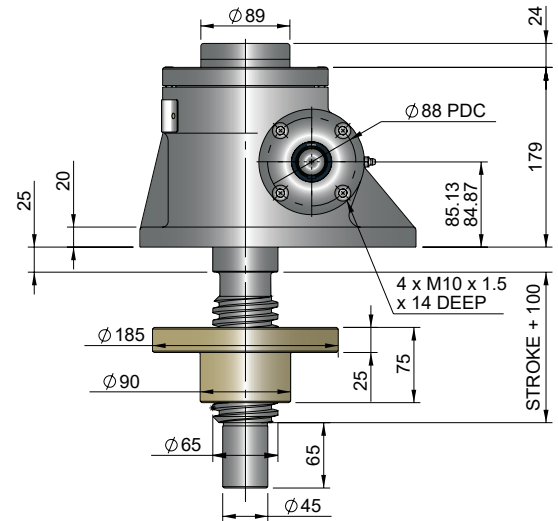

## Closed Height & Bellows Boots

Closed Height "C"	Threaded End		Top Plate		Clevis End		Fork End		Rod End	
	Upright	Inverted	Upright	Inverted	Upright	Inverted	Upright	Inverted	Upright	Inverted
EMT0200	265	95	265	95	310	140	400	230	367	197
Stroke (mm)	EMT0200 with Bellows Boots									
1-300	265	120	265	120	310	165	400	255	387	242
301-600	265	145	265	145	310	190	400	280	387	267
601-1050	290	145	290	145	335	190	425	280	412	267
1051-1500	315	170	315	170	360	215	450	305	437	292

Model	A	B	D	E	G
EMT0200	75	165	20	20	165

Stroke	1-300	301-600	601-1050	1051-1500
EMT0200	20	30	50	70

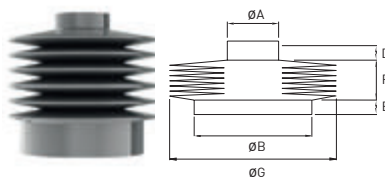

## Column Strength

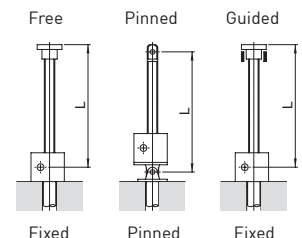
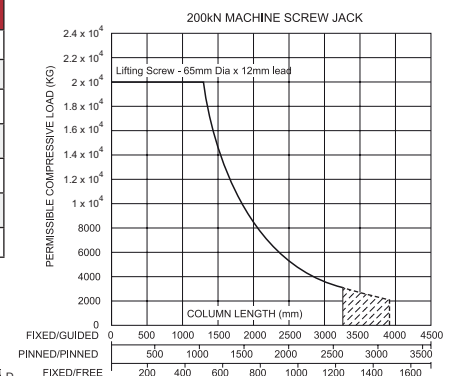

Note:

- 1 Inverted Screw Jacks - Bellows Boot Closed Height assumes screw jack mounted on a structure with thickness = 15mm
- 2 Inverted Screw Jacks - Recommended bellows boot mounting plate  $\varnothing B \times [E + 5mm]$  thick.
- 3 Inverted Screw Jacks - Screw Jack mounting plate & bellows boot mounting plate are customers own supply
- 4 † Control tapes fitted (increase outer diameter by 20mm approximately).
- 5 For horizontal installations with than 450 mm of stroke, internal boot guides are recommended.
- 6 Customers with threaded end screw jacks must provide a fixing for the unattached bellows boot collar.
- 7 Bellows boots for Rotating Screw Jacks, other sizes, stroke and materials please consult Power Jacks.



## Upright EMT0300-V00

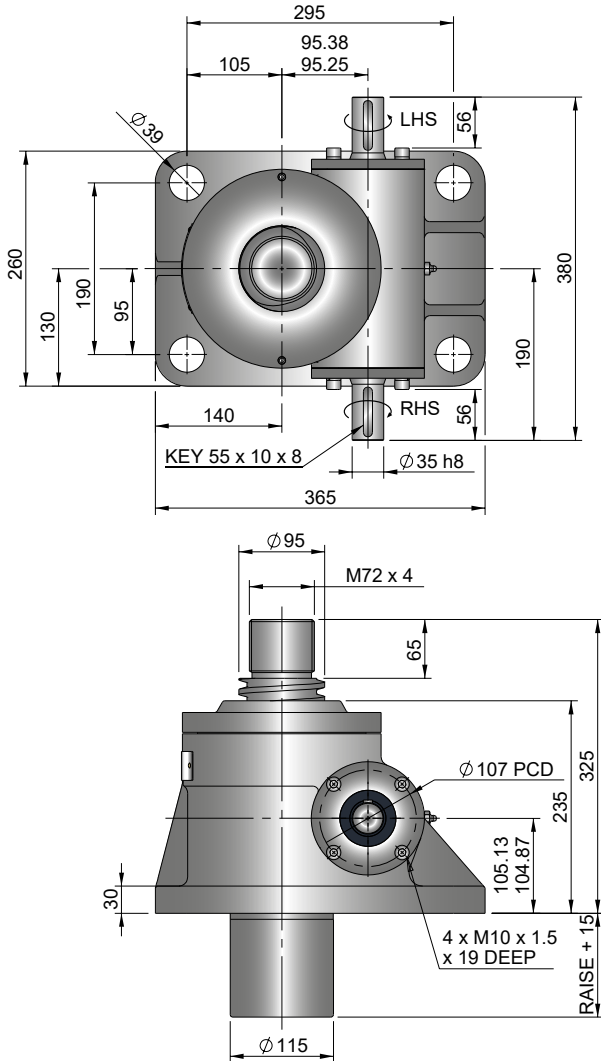

## Inverted EMT0300-J00

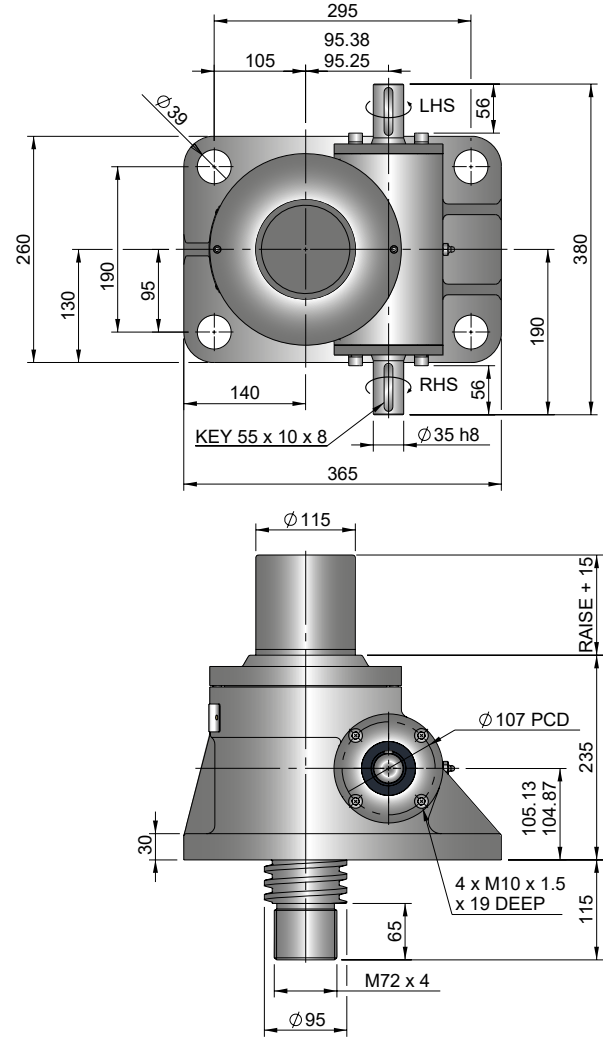

## Performance

Model	EMT0300 EMR0300		
Capacity (kN)	300		
Sustaining Capacity (kN)	Standard 316 Lifting Screw	Tension	200
		Compression	300
	Duplex Lifting Screw		300
Operating Capacity (kN)	Standard 316 Worm Shaft		100
	Duplex or Plated Worm Shaft with 316 Screw	Tension	200
		Compression	300
	Duplex or Plated Worm Shaft with Duplex Screw		300
Lifting Screw	Diameter (mm)		95
	Lead	Option	1
		mm	16
Gear Ratio Option 1	Gear Ratio		10 2/3:1
	Screw Jack Static Efficiency		0.149   0.232
	Screw Jack Dynamic Efficiency		0.205   0.308
Gear Ratio Option 2	Gear Ratio		32:1
	Screw Jack Static Efficiency		0.084   0.131
	Screw Jack Dynamic Efficiency		0.128   0.192

## Closed Height

Model	EMT0300 EMR0300		
Capacity	kN		300
Lifting Screw Lead (mm)			16   32
Turn of worm for travel of lifting screw	Gear Ratio 1	1 Turn	1.5mm   3mm
	Gear Ratio 2	4 Turn	2mm   4mm
Maximum Through Torque (Nm)		1440	
Lifting Screw Restraining Torque (Nm)		2805   3610	
Worm Shaft Maximum Radial Load (N)		2170	
Maximum Input Speed (rpm)		1800	
Gear Case Material		Stainless Steel	
Weight (kg) - stroke = 150mm	EMT	92.4	
	EMR	113.78	
Weight (kg) - per extra 25mm stroke	EMT	1.55	
	EMR	1.13	

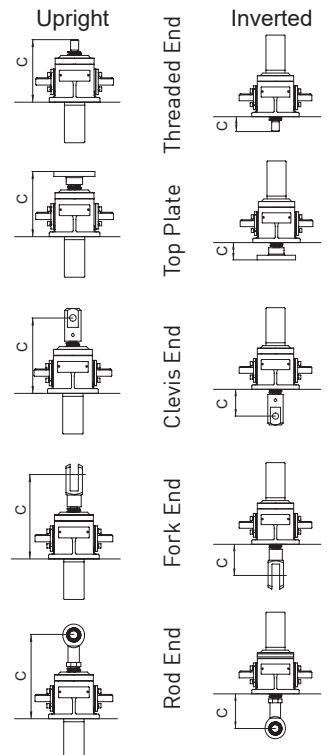

Note: All dimension in millimetres unless otherwise stated.  
Designs subject to change without notice

## Upright EMR0300-V00

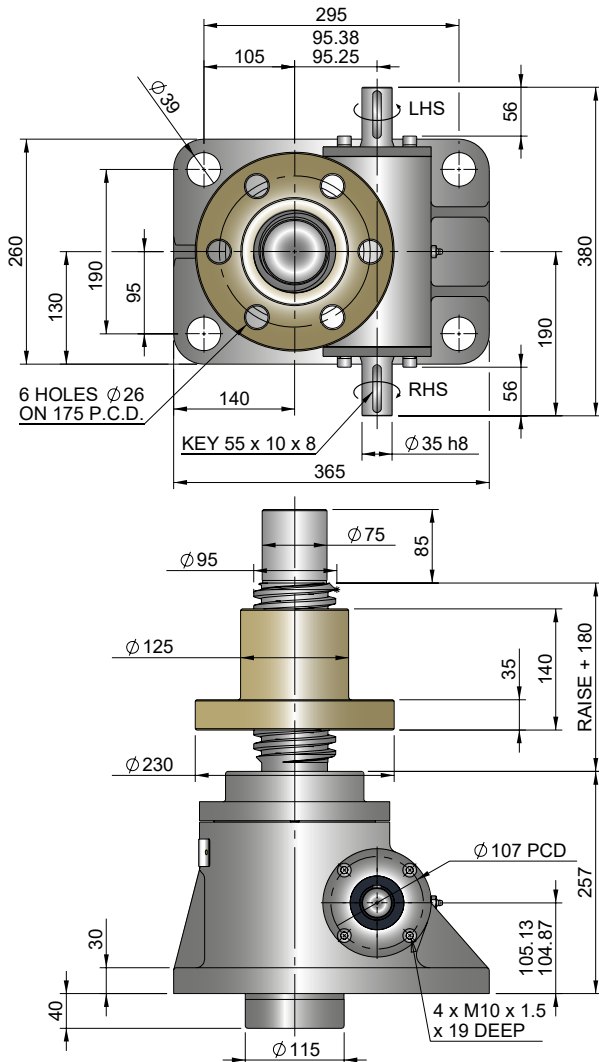

## Inverted EMR0300-J00

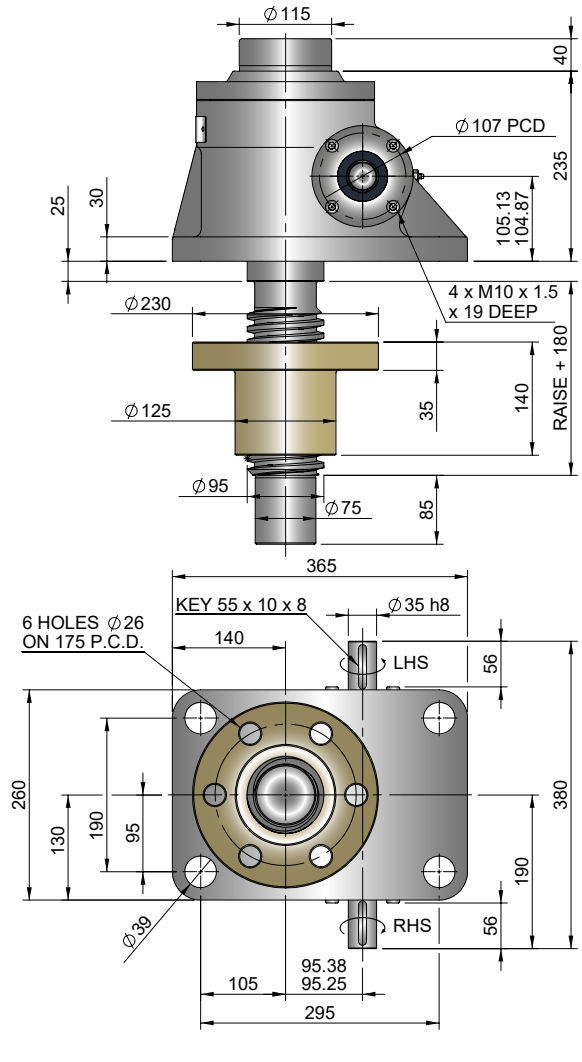

## Closed Height & Bellows Boots

Closed Height "C"	Threaded End		Top Plate		Clevis End		Fork End		Rod End	
	Upright	Inverted	Upright	Inverted	Upright	Inverted	Upright	Inverted	Upright	Inverted
EMT0300	325	115	325	115	365	155	on request		on request	
Stroke (mm)	EMT0300 with Bellows Boots									
1-300	325	140	325	140	365	180	-	-	-	-
301-600	325	165	325	165	365	205	-	-	-	-
601-1050	350	165	350	165	390	205	-	-	-	-
1051-1500	375	190	375	190	415	230	-	-	-	-

Model	A	B	D	E	G
EMT0300	110	220	20	20	191

Stroke	1-300	301-600	601-1050	1051-1500
EMT0300	20	30	50	70

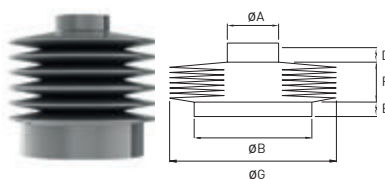

## Column Strength

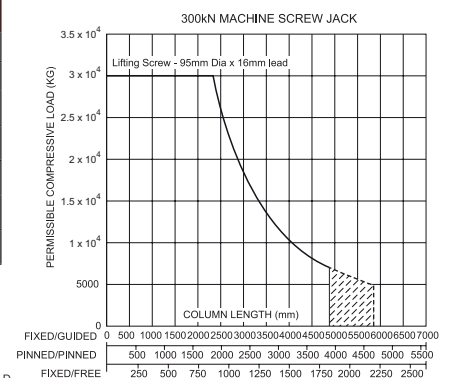

Note:

- 1 Inverted Screw Jacks - Bellows Boot Closed Height assumes screw jack mounted on a structure with thickness = 15mm
- 2 Inverted Screw Jacks - Recommended bellows boot mounting plate  $\varnothing B \times [E + 5mm]$  thick.
- 3 Inverted Screw Jacks - Screw Jack mounting plate & bellows boot mounting plate are customers own supply
- 4 † Control tapes fitted (increase outer diameter by 20mm approximately).
- 5 For horizontal installations with than 450 mm of stroke, internal boot guides are recommended.
- 6 Customers with threaded end screw jacks must provide a fixing for the unattached bellows boot collar.
- 7 Bellows boots for Rotating Screw Jacks, other sizes, stroke and materials please consult Power Jacks.

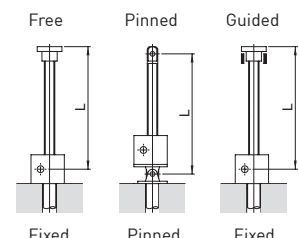

## Upright EMT0500-V00

## Inverted EMT0500-J00

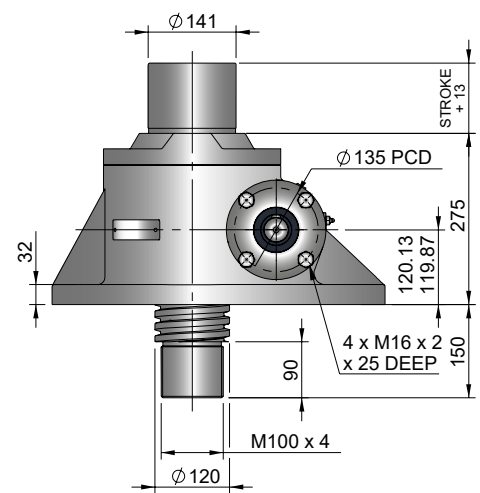
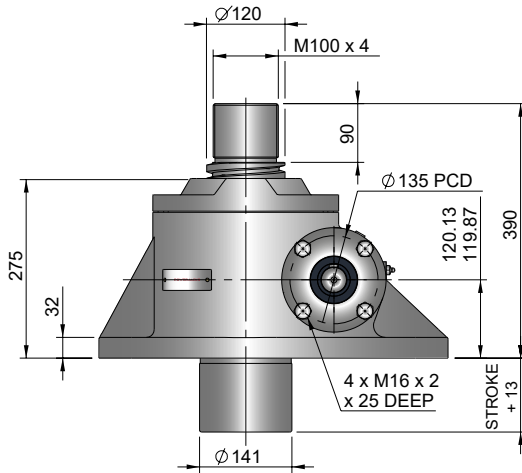
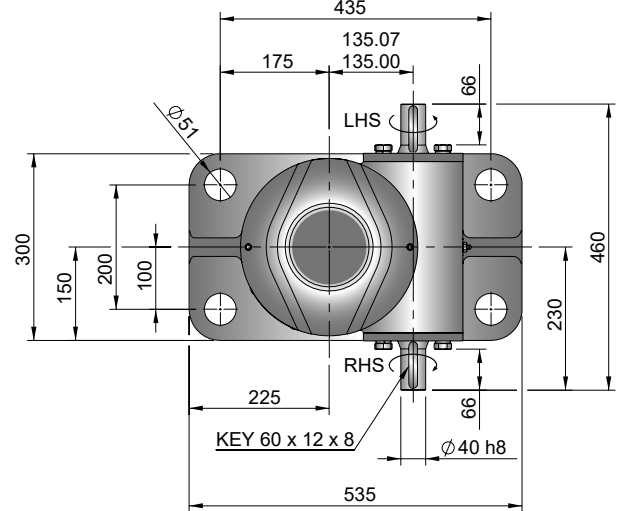
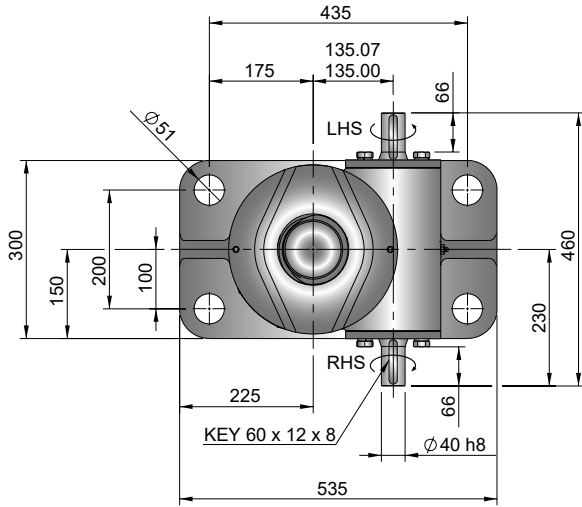

## Performance

## Closed Height

Model	EMT0500 EMR0500		
Capacity (kN)	500		
Sustaining Capacity (kN)	Standard 316 Lifting Screw	Tension	333
		Compression	500
	Duplex Lifting Screw	500	
Operating Capacity (kN)	Standard 316 Worm Shaft		167
	Duplex or Plated Worm Shaft with 316 Screw	Tension	333
		Compression	500
	Duplex or Plated Worm Shaft with Duplex Screw		500
Lifting Screw	Diameter (mm)		120
	Lead	Option	1   2
		mm	16   32
Gear Ratio Option 1	Gear Ratio		10 2/3:1
	Screw Jack Static Efficiency		0.132   0.215
	Screw Jack Dynamic Efficiency		0.181   0.284
Gear Ratio Option 2	Gear Ratio		32:1
	Screw Jack Static Efficiency		0.079   0.129
	Screw Jack Dynamic Efficiency		0.120   0.188

Model	EMT0500 EMR0500			
Capacity	kN		500	
Lifting Screw Lead (mm)			16   32	
Turn of worm for travel of lifting screw	Gear Ratio	1 Turn	1.5mm   3mm	
		4 Turn	2mm   4mm	
Maximum Through Torque (Nm)			2712	
Lifting Screw Restraining Torque (Nm)			5645   6975	
Worm Shaft Maximum Radial Load (N)			2190	
Maximum Input Speed (rpm)			1800	
Gear Case Material			Stainless Steel	
Weight (kg) - stroke = 150mm			EMT	183.7
			EMR	224
Weight (kg) - per extra 25mm stroke			EMT	2.48
			EMR	1.94

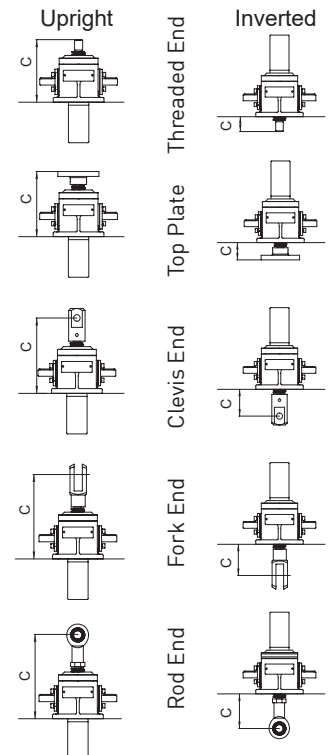

Note: All dimension in millimetres unless otherwise stated.  
Designs subject to change without notice

## Upright EMR0500-V00

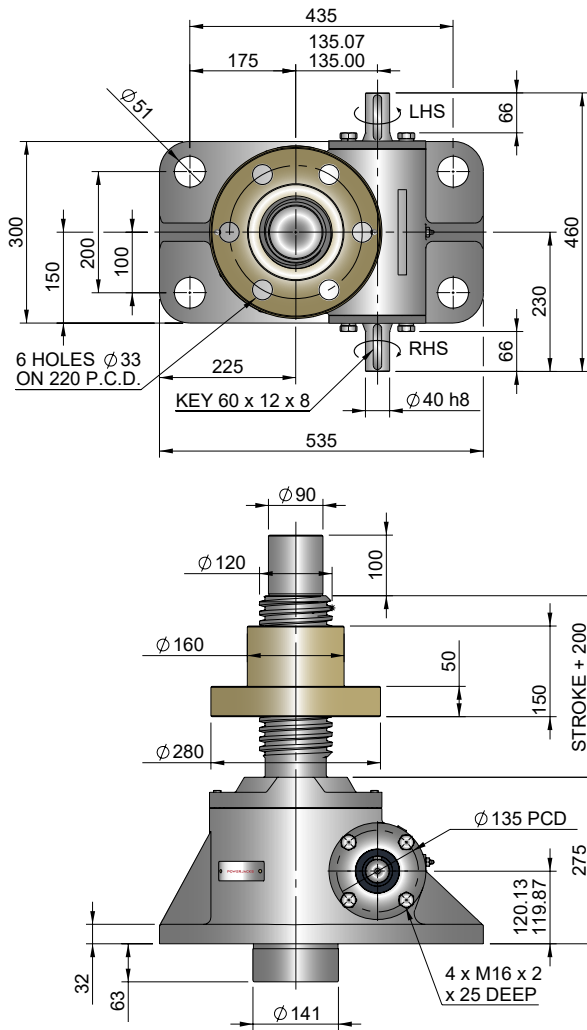

## Inverted EMR0500-J00

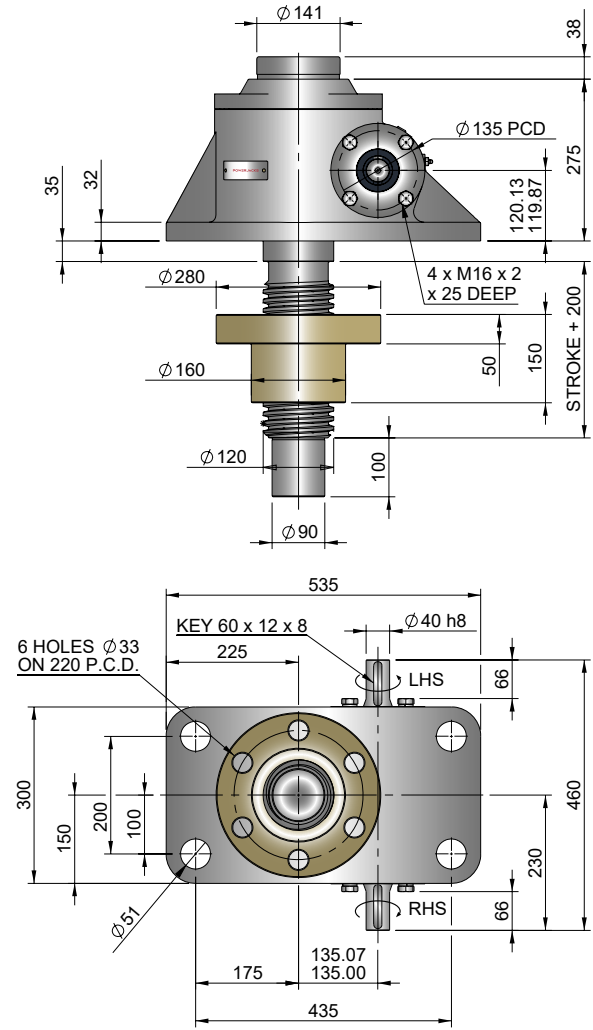

## Closed Height & Bellows Boots

Closed Height "C"	Threaded End		Top Plate		Clevis End		Fork End		Rod End	
	Upright	Inverted	Upright	Inverted	Upright	Inverted	Upright	Inverted	Upright	Inverted
EMT0500	390	150	390	150	440	200	on request		on request	
Stroke (mm)	EMT0500 with Bellows Boots									
1-300	390	175	390	175	440	225	-	-	-	-
301-600	415	200	415	200	465	250	-	-	-	-
601-1050	440	225	440	225	490	275	-	-	-	-
1051-1500	465	250	465	250	515	300	-	-	-	-

Model	A	B	D	E	G
EMT0500	150	285	20	45	210

Stroke	1-300	301-600	601-1050	1051-1500
EMT0500	20	30	50	70

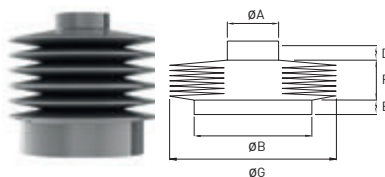

## Column Strength

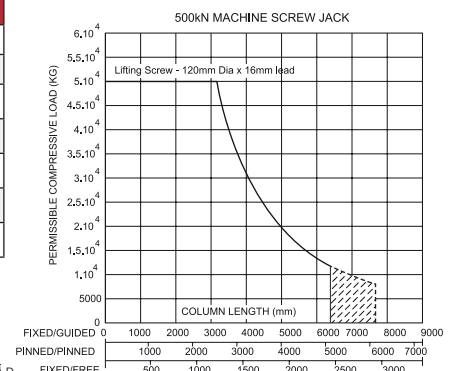

Note:

- 1 Inverted Screw Jacks - Bellows Boot Closed Height assumes screw jack mounted on a structure with thickness = 15mm
- 2 Inverted Screw Jacks - Recommended bellows boot mounting plate  $\varnothing B \times [E + 5mm]$  thick.
- 3 Inverted Screw Jacks - Screw Jack mounting plate & bellows boot mounting plate are customers own supply
- 4 † Control tapes fitted (increase outer diameter by 20mm approximately).
- 5 For horizontal installations with than 450 mm of stroke, internal boot guides are recommended.
- 6 Customers with threaded end screw jacks must provide a fixing for the unattached bellows boot collar.
- 7 Bellows boots for Rotating Screw Jacks, other sizes, stroke and materials please consult Power Jacks.

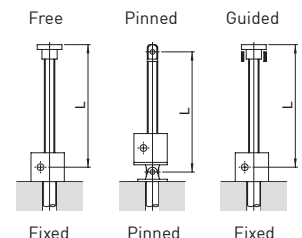

## Upright EMT1000-V00

## Inverted EMT1000-J00

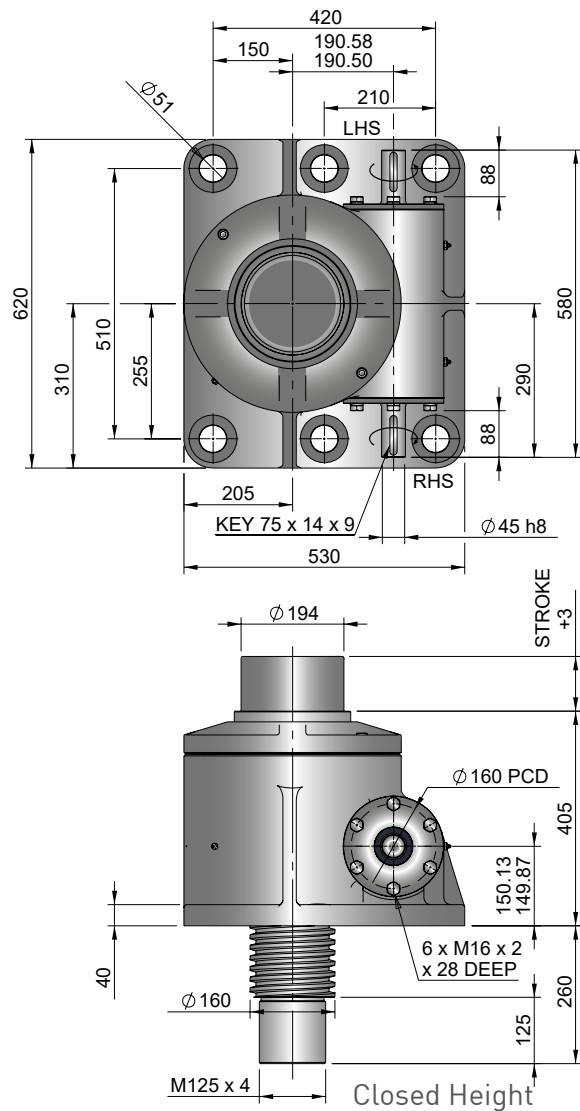
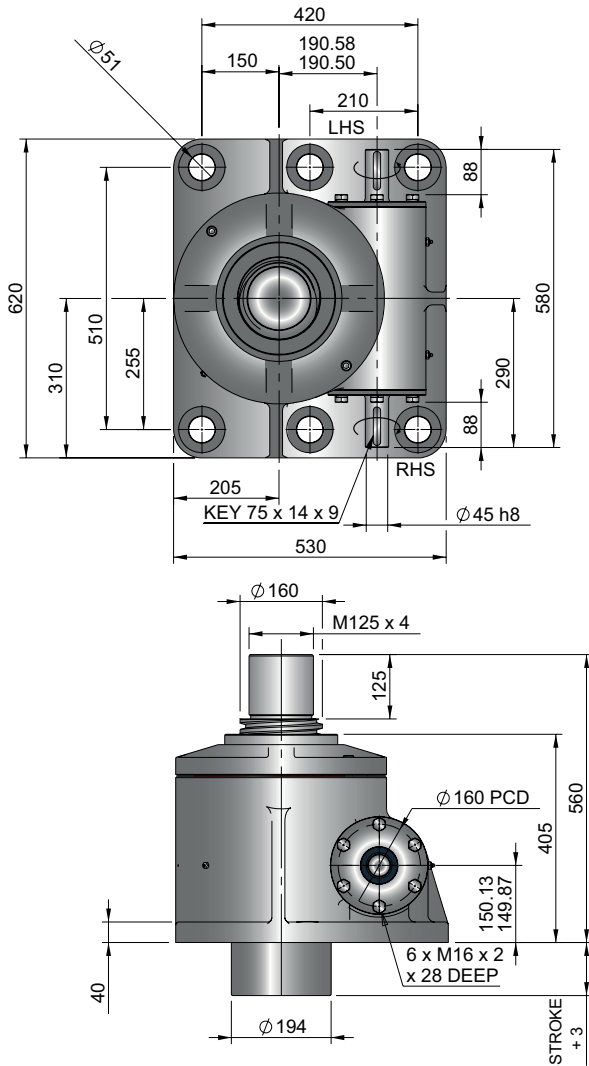

## Performance

Model			EMT1000 EMR1000
Capacity (kN)			1000
Sustaining Capacity (kN)	Standard 316 Lifting Screw	Tension	666
		Compression	1000
Duplex Lifting Screw			1000
Operating Capacity (kN)	Standard 316 Worm Shaft		333
	Duplex or Plated Worm Shaft with 316 Screw	Tension	666
		Compression	1000
Duplex or Plated Worm Shaft with Duplex Screw			1000
Lifting Screw	Diameter (mm)		160
	Lead	Option	1
		mm	20
Gear Ratio Option 1	Gear Ratio		12:1
	Screw Jack Static Efficiency		0.131
	Screw Jack Dynamic Efficiency		0.178
Gear Ratio Option 2	Gear Ratio		36:1
	Screw Jack Static Efficiency		0.079
	Screw Jack Dynamic Efficiency		0.123

Model			EMT1000 EMR1000	
Capacity	kN		1000	
Lifting Screw Lead (mm)			20	
Turn of worm for travel of lifting screw	Gear Ratio 1	1 Turn	1.67mm	
	Gear Ratio 2	4 Turn	6.67mm	
Maximum Through Torque (Nm)			6075	
Lifting Screw Restraining Torque (Nm)			14890	
Worm Shaft Maximum Radial Load (N)			2220	
Maximum Input Speed (rpm)			1800	
Gear Case Material			Stainless Steel	
Weight (kg) - stroke = 150mm			EMT	459.1
			EMR	560.4
Weight (kg) - per extra 25mm stroke			EMT	4.11
			EMR	3.38

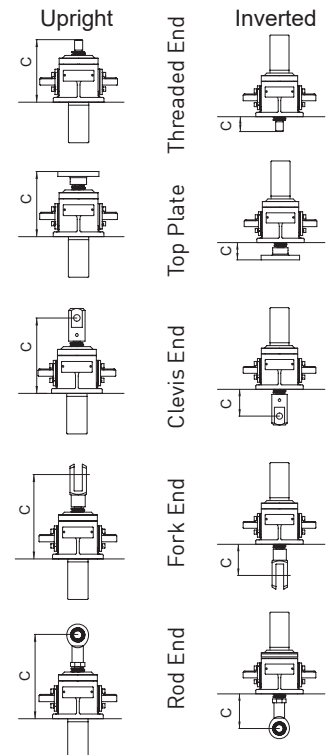

Note: All dimension in millimetres unless otherwise stated.  
Designs subject to change without notice

## Upright EMR1000-V00

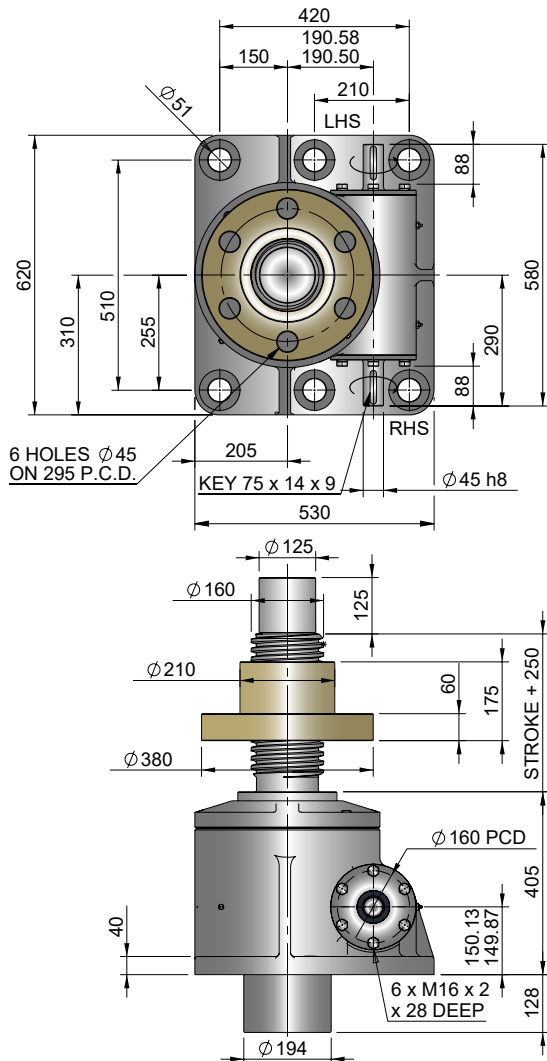

## Inverted EMR1000-J00

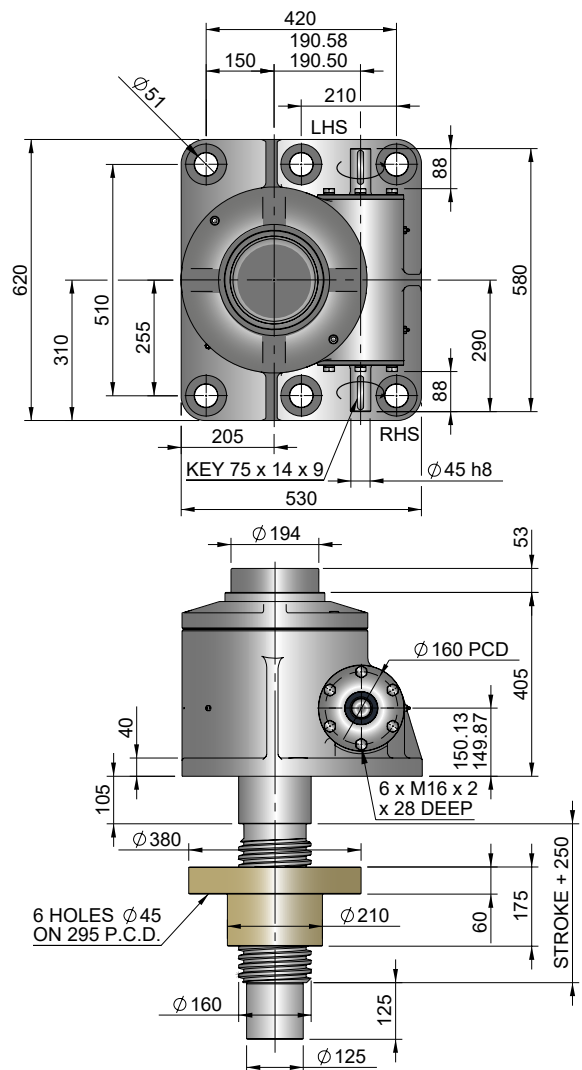

## Closed Height & Bellows Boots

Closed Height "C"	Threaded End		Top Plate		Clevis End		Fork End		Rod End	
	Upright	Inverted	Upright	Inverted	Upright	Inverted	Upright	Inverted	Upright	Inverted
EMT1000	560	260	560	260	625	325	on request		on request	
Stroke (mm)	EMT1000 with Bellows Boots									
1-300	560	260	560	260	625	325	-	-	-	-
301-600	560	260	560	260	625	325	-	-	-	-
601-1050	585	285	585	285	650	350	-	-	-	-
1051-1500	610	310	610	310	675	375	-	-	-	-

Model	A	B	D	E	G
EMT1000	200	220	20	20	244

Stroke	1-300	301-600	601-1050	1051-1500
EMT1000	20	30	50	70

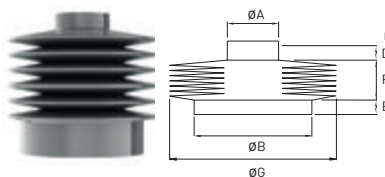

## Column Strength

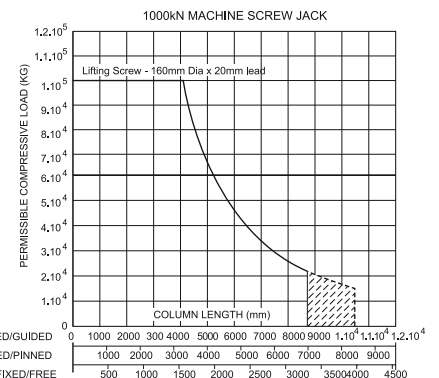

Note:

- 1 Inverted Screw Jacks - Bellows Boot Closed Height assumes screw jack mounted on a structure with thickness = 15mm
- 2 Inverted Screw Jacks - Recommended bellows boot mounting plate ØB x [E +5mm] thick.
- 3 Inverted Screw Jacks - Screw Jack mounting plate & bellows boot mounting plate are customers own supply
- 4 † Control tapes fitted (increase outer diameter by 20mm approximately).
- 5 For horizontal installations with than 450 mm of stroke, internal boot guides are recommended.
- 6 Customers with threaded end screw jacks must provide a fixing for the unattached bellows boot collar.
- 7 Bellows boots for Rotating Screw Jacks, other sizes, stroke and materials please consult Power Jacks.

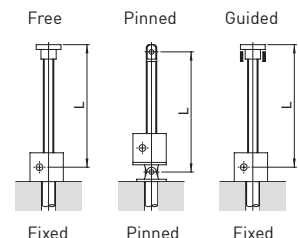

E-Series

4

## E-Series Stainless Steel Screw Jacks

PERFORMANCE  
ENHANCED VARIANTS  
TO SOLVE SPECIFIC  
APPLICATION  
REQUIREMENTS



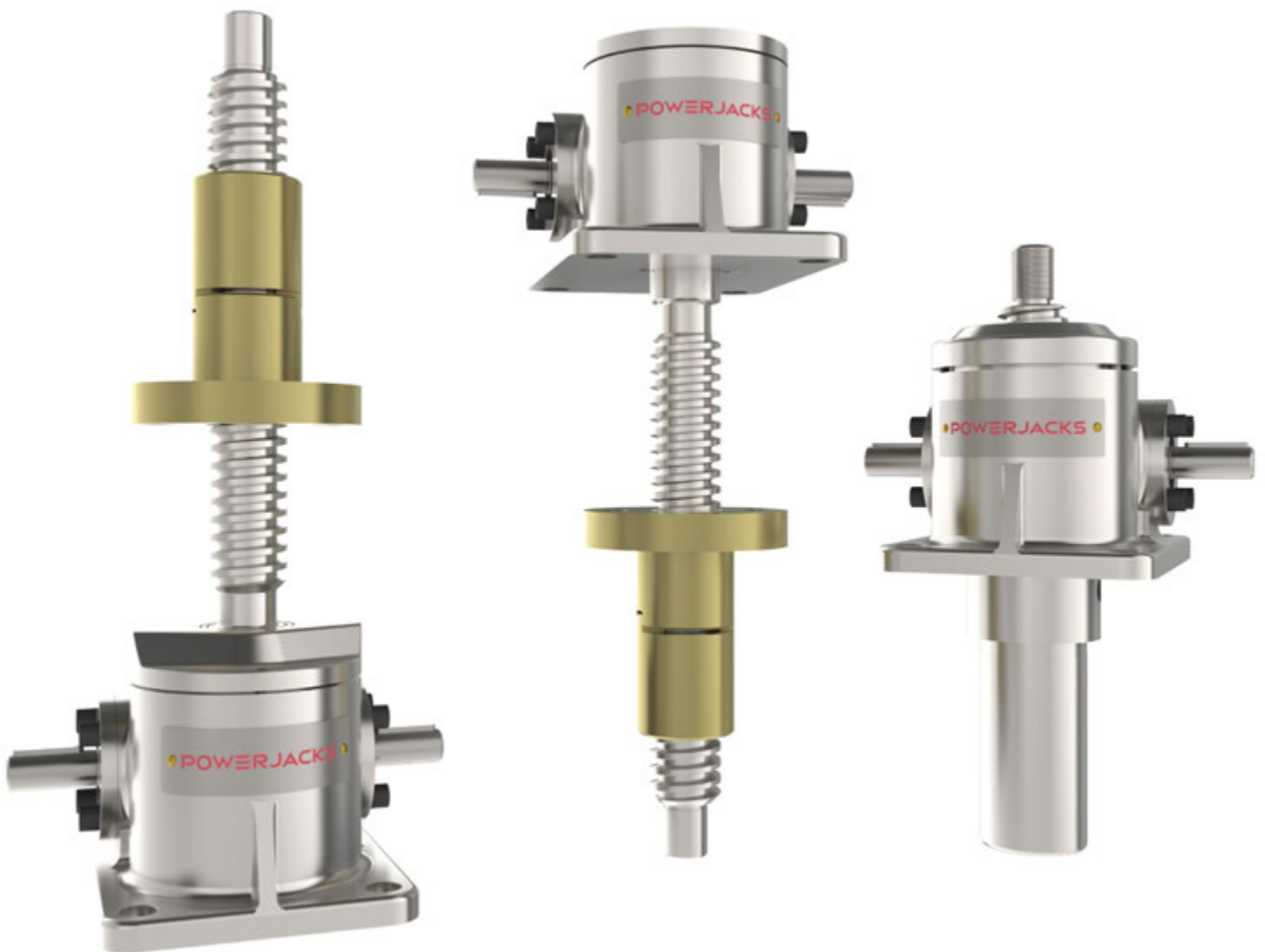

## Minimise Axial Backlash for Reversing Loads

The Anti-Backlash feature provides a reliable method to regulate the axial backlash in a screw jack for applications where there is a reversal of loading from tension to compression. The amount of backlash between the screw and worm gear nut can be adjusted (adjust shell cap) to a desired amount or a practical minimum. To avoid binding and excessive wear do not adjust backlash to less than 0.025mm.

The Anti-Backlash feature also acts as a safety device, providing dual nut load carrying unit, when the worm gear becomes worn.

A visual wear indicator is available on request for all models and a "feeler" gauge can be used to measure the wear. This can be upgraded to use a sensor for wear monitoring. Consult Power Jacks for either option.

Anti-Backlash Nut      Anti-Backlash Gear

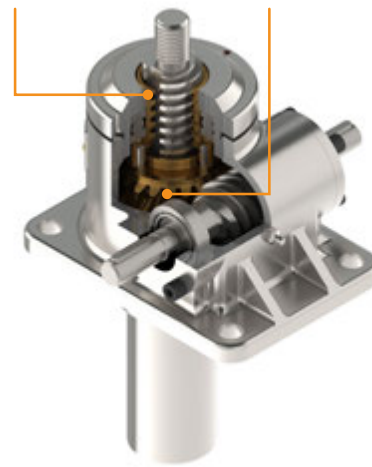

## Dimensions

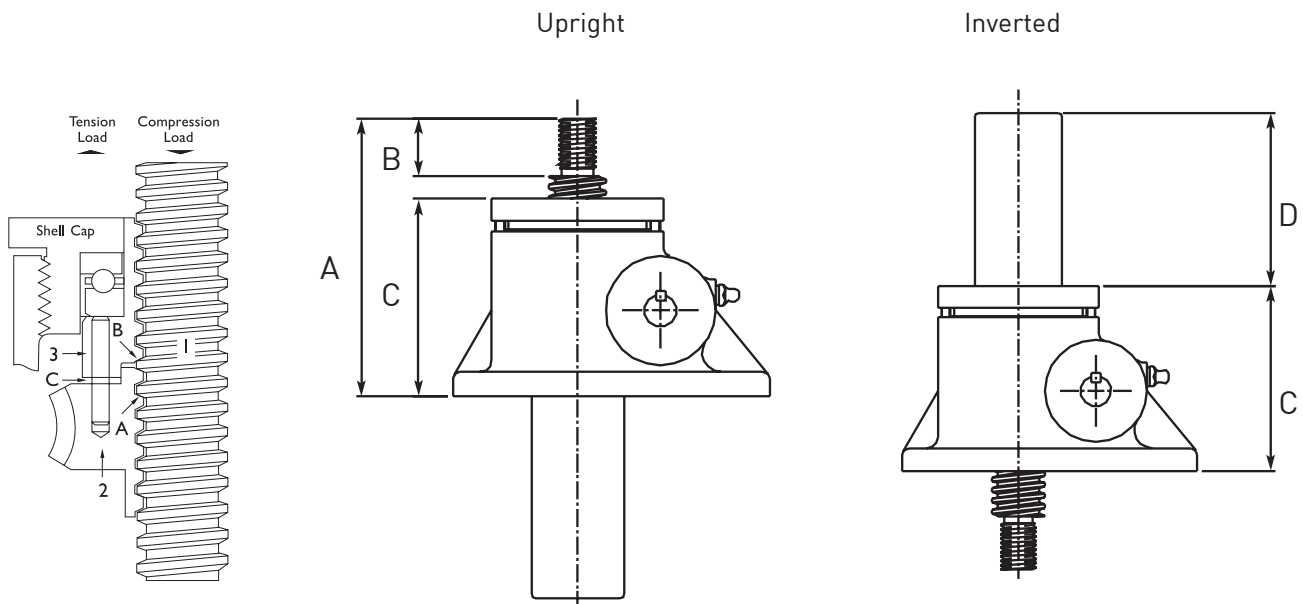

How it works - refer p193

The dimensions for these screw jacks are the same as the standard units except those detailed below.

Model	EMT0010	EMT0025	EMT0050	EMT0100	EMT0200	EMT0300	EMT0500	EMT1000
A	125	145	185	200	265	340	415	585
B	24	30	35	40	55	65	90	125
C	86	103.5	138	146.5	195	250	295	415
D	Stroke + 35	Stroke + 30	Stroke + 20	Stroke + 3	Stroke + 24	Stroke + 38	Stroke + 28	Stroke + 3

## E-Series - Stainless Steel Screw Jacks - Anti-Backlash - Performance

Model		EMT0010-V0A EMT0010-J0A		EMT0025-V0A EMT0025-J0A		EMT0050-V0A EMT0050-J0A		EMT0100-V0A EMT0100-J0A		
Capacity	kN	10		25		50		100		
Sustaining Capacity (kN)	Tension	6.6		16.5		33		66		
	Compression	10		25		50		100		
Operating Capacity (kN)	Stainless Steel Worm Shaft		3.3		8.25		16.5		33	
	Plated Worm Shaft	Tension	6.6		16.5		33		66	
		Compression	10		25		50		100	
Lifting Screw <sup>1</sup>	mm		20		30		40		55	
	Lead	Option	1	2	1	2	1	2	1	2
		mm	5	10	6	12	9	18	12	24
Gear Ratios	Option 1		5:1		6:1		6:1		8:1	
	Option 2		20:1		24:1		24:1		24:1	
Max. Input Power (kW)	Gear Ratio Option 1		0.375		1.5		3.0		3.75	
	Gear Ratio Option 2		0.19		0.375		0.55		1.125	
Start up torque at full load (Nm) <sup>2</sup>	Gear Ratio Option 1		7.8	10.9	23.5	31.3	62.3	84.9	129.2	147.8
	Gear Ratio Option 2		3.6	5.1	9.8	13.0	28.5	38.8	66.8	90.4
Weight (kg) - stroke = 150mm		2.72		8.62		16.78		26.12		
Weight (kg) per extra 25mm		0.13		0.21		0.32		0.57		
Gear Ratio Option 1	Gear Ratio		5:1		6:1		6:1		8:1	
	Screw Jack Static Efficiency		0.203	0.291	0.169	0.254	0.192	0.281	0.185	0.273
	Screw Jack Dynamic Efficiency		0.263	0.365	0.222	0.322	0.251	0.356	0.243	0.325
Gear Ratio Option 2	Gear Ratio		20:1		24:1		24:1		24:1	
	Screw Jack Static Efficiency		0.109	0.157	0.102	0.153	0.105	0.154	0.119	0.176
	Screw Jack Dynamic Efficiency		0.159	0.220	0.150	0.217	0.154	0.218	0.172	0.245

Model		EMT0200-V0A EMT0200-J0A		EMT0300-V0A EMT0300-J0A		EMT0500-V0A EMT0500-J0A		EMT1000-V0A EMT1000-J0A		
Capacity	kN	200		300		500		1000		
Sustaining Capacity (kN)	Tension	132		200		333		666		
	Compression	200		300		500		1000		
Operating Capacity (kN)	Stainless Steel Worm Shaft		3.3		100		167		333	
	Plated Worm Shaft	Tension	6.6		200		333		666	
		Compression	10		300		500		1000	
Lifting Screw <sup>1</sup>	mm		65		95		120		160	
	Lead	Option	1	2	1	2	1	2	1	
		mm	12	24	16	32	16	32	20	
Gear Ratios	Option 1		8:1		10 2/3:1		10 2/3:1		12:1	
	Option 2		24:1		32:1		32:1		36:1	
Max. Input Power (kW)	Gear Ratio Option 1		3.75		6.0		11.25		18.5	
	Gear Ratio Option 2		1.125		1.9		4.5		8.25	
Start up torque at full load (Nm) <sup>2</sup>	Gear Ratio Option 1		281.2	368.5	534	687	1000	1236	2243	
	Gear Ratio Option 2		153.7	201.4	315	405	568	702	1244	
Weight (kg) - stroke = 150mm		49		91		209		610		
Weight (kg) per extra 25mm		0.86		1.58		2.49		4.31		
Gear Ratio Option 1	Gear Ratio		8:1		10 2/3:1		10 2/3:1		12:1	
	Screw Jack Static Efficiency		0.170	0.259	0.134	0.209	0.119	0.193	0.118	
	Screw Jack Dynamic Efficiency		0.226	0.332	0.184	0.277	0.163	0.256	0.160	
Gear Ratio Option 2	Gear Ratio		24:1		32:1		32:1		36:1	
	Screw Jack Static Efficiency		0.104	0.158	0.076	0.118	0.070	0.113	0.071	
	Screw Jack Dynamic Efficiency		0.151	0.222	0.115	0.173	0.105	0.165	0.106	

**Note**

1. All metric machine screws have a trapezoidal thread form.
2. For loads of 25% to 100% of screw jack capacity, torque requirements are approximately proportional to the load.
3. Efficiency values for standard grease lubricated worm gear box and lifting screw.
4. All E-Series screw jacks have grease lubricated gearbox and lead screw as standard.

## Linear Movement for Rotationally Unconstrained Loads

The Anti-Rotation feature for translating screw jacks stops the lifting screw from rotating without the need for end fixing. This is done by keying the lifting screw.

### Benefits:

- Compact unit integrates anti-rotation into gearbox
- Dimensions are the same as the standard translating screw jack
- Standard round cover pipe for easy installation
- Proven industrial anti-rotation design

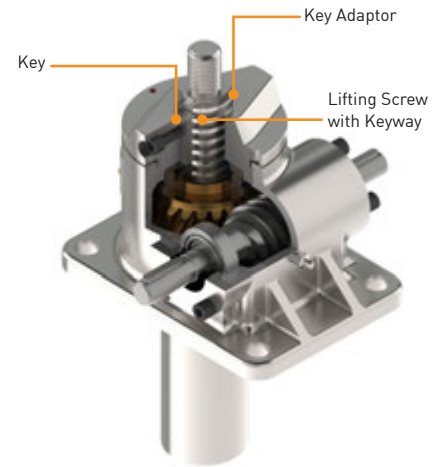

## Dimensions

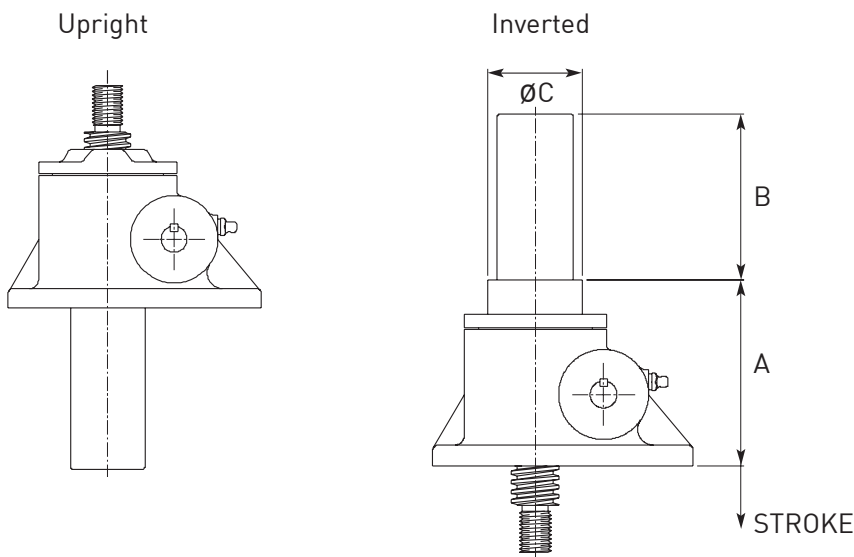

## Dimensions for Upright Models with Anti-Rotation (Keyed)

The Dimensions for upright E-Series machine screw jacks with anti-rotation (keyed) mechanism are the same as the standard screw jacks without the feature.

## Dimensions for Inverted Models with Anti-Rotation (Keyed)

The dimensions for these screw jacks are the same as the standard units except those detailed below.

Model	EMT0010	EMT0025	EMT0050	EMT0100	EMT0200	EMT0300	EMT0500	EMT1000
A	78	125.5	159	167.5	210	267	307	445
B	Stroke + 35	Stroke + 30	Stroke + 20	Stroke + 3	Stroke - 1	Stroke + 15	Stroke + 13	Stroke + 3
øC	N/A	60	75	90	102	141.5	180	236

## E-Series - Stainless Steel Screw Jacks - Anti-Rotation (Keyed) - Performance

Model		EMT0010-VK0 EMT0010-JK0		EMT0025-VK0 EMT0025-JK0		EMT0050-VK0 EMT0050-JK0		EMT0100-VK0 EMT0100-JK0		
Capacity	kN	10		25		50		100		
Sustaining Capacity (kN)	Tension	6.6		16.5		33		66		
	Compression	10		25		50		100		
Operating Capacity (kN)	Stainless Steel Worm Shaft		3.3		8.25		16.5		33	
	Plated Worm Shaft	Tension	6.6		16.5		33		66	
		Compression	10		25		50		100	
Lifting Screw <sup>1</sup>	mm		20		30		40		55	
	Lead	Option	1	2	1	2	1	2	1	2
		mm	5	10	6	12	9	18	12	24
Gear Ratios	Option 1		5:1		6:1		6:1		8:1	
	Option 2		20:1		24:1		24:1		24:1	
Max. Input Power (kW)	Gear Ratio Option 1		0.375		1.5		3.0		3.75	
	Gear Ratio Option 2		0.19		0.375		0.55		1.125	
Start up torque at full load (Nm) <sup>2</sup>	Gear Ratio Option 1		7.1	9.9	20.8	27.7	58.7	80	121.7	164.7
	Gear Ratio Option 2		3.1	4.4	9.2	12.2	26.8	36.6	63.6	86.1
Weight (kg) - stroke = 150mm		2.27		8.17		15.88		24.72		
Weight (kg) per extra 25mm		0.13		0.21		0.32		0.57		
Gear Ratio Option 1	Gear Ratio		5:1		6:1		6:1		8:1	
	Screw Jack Static Efficiency		0.224	0.322	0.191	0.287	0.203	0.299	0.196	0.290
	Screw Jack Dynamic Efficiency		0.291	0.403	0.251	0.364	0.267	0.378	0.258	0.368
Gear Ratio Option 2	Gear Ratio		20:1		24:1		24:1		24:1	
	Screw Jack Static Efficiency		0.127	0.182	0.108	0.162	0.111	0.163	0.125	0.185
	Screw Jack Dynamic Efficiency		0.184	0.255	0.159	0.230	0.164	0.232	0.180	0.257

Model		EMT0200-VK0 EMT0200-JK0		EMT0300-VK0 EMT0300-JK0		EMT0500-VK0 EMT0500-JK0		EMT1000-VK0 EMT1000-JK0		
Capacity	kN	200		300		500		1000		
Sustaining Capacity (kN)	Tension	200		300		500		1000		
	Compression	132		200		333		666		
Operating Capacity (kN)	Stainless Steel Worm Shaft		200		300		500		1000	
	Plated Worm Shaft	Tension	3.3		100		167		333	
		Compression	6.6		200		333		666	
Lifting Screw <sup>1</sup>	mm		10		300		500		1000	
	Lead	Option	65		95		120		160	
		mm	12	24	16	32	16	32	20	
Gear Ratios	Option 1		8:1		10 2/3:1		10 2/3:1		12:1	
	Option 2		24:1		32:1		32:1		36:1	
Max. Input Power (kW)	Gear Ratio Option 1		3.75		6.0		11.25		18.5	
	Gear Ratio Option 2		1.125		1.9		4.5		8.25	
Start up torque at full load (Nm) <sup>2</sup>	Gear Ratio Option 1		275.3	360.7	506	651	947	1170	2125	
	Gear Ratio Option 2		144	188.7	298	384	526	650	1126	
Weight (kg) - stroke = 150mm		45		86		195		553		
Weight (kg) per extra 25mm		0.86		1.58		2.49		4.31		
Gear Ratio Option 1	Gear Ratio		8:1		10 2/3:1		10 2/3:1		12:1	
	Screw Jack Static Efficiency		0.173	0.265	0.142	0.220	0.126	0.204	0.125	
	Screw Jack Dynamic Efficiency		0.230	0.34	0.195	0.292	0.172	0.270	0.169	
Gear Ratio Option 2	Gear Ratio		24:1		32:1		32:1		36:1	
	Screw Jack Static Efficiency		0.111	0.169	0.080	0.124	0.076	0.122	0.079	
	Screw Jack Dynamic Efficiency		0.161	0.237	0.121	0.182	0.144	0.178	0.117	

**Note**

1. All metric machine screws have a trapezoidal thread form.
2. For loads of 25% to 100% of screw jack capacity, torque requirements are approximately proportional to the load.
3. Efficiency values for standard grease lubricated worm gear box and lifting screw.
4. All E-Series screw jacks have grease lubricated gearbox and lead screw as standard.

### Combine Anti-Backlash & Anti-Rotation in One Screw Jack

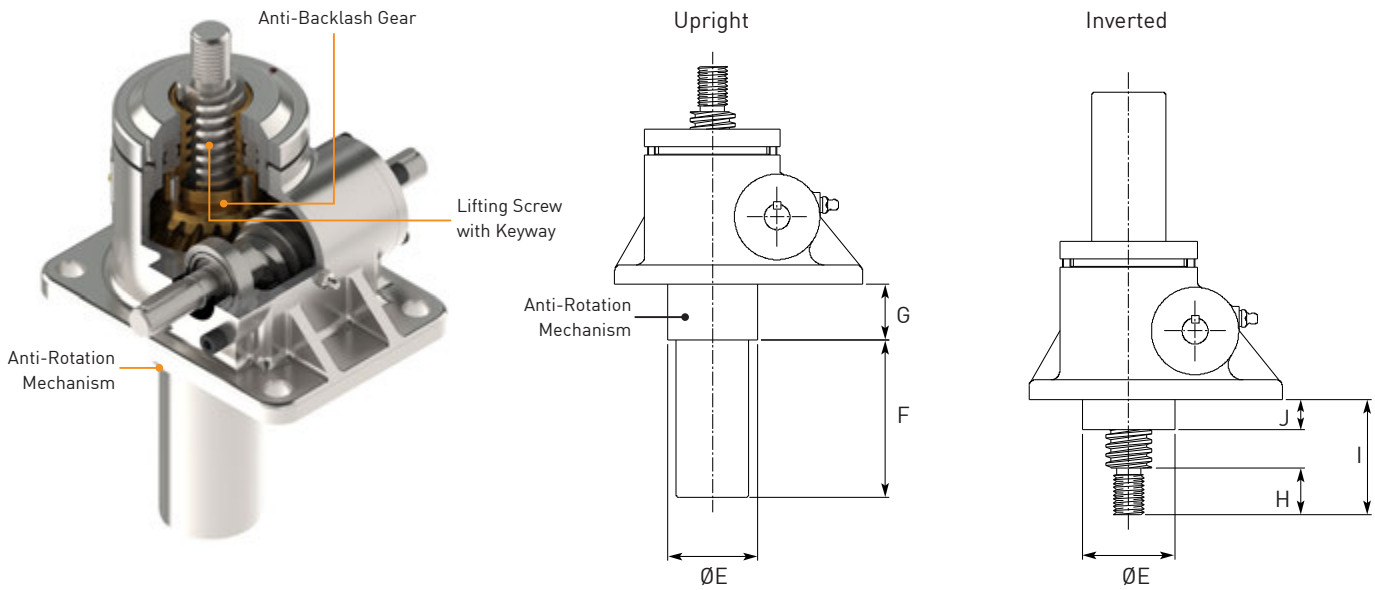

### Dimensions for E-Series Stainless Steel Screw Jacks with Anti-Backlash & Anti-Rotation

Model	EMT0010-VKA EMT0010-JKA	EMT0025-VKA EMT0025-JKA	EMT0050-VKA EMT0050-JKA	EMT0100-VKA EMT0100-JKA	EMT0200-VKA EMT0200-JKA	EMT0300-VKA EMT0300-JKA	EMT0500-VKA EMT0500-JKA	EMT1000-VKA EMT1000-JKA
ØE	38	60	75	90	102	138	206	264
F	Stroke + 9	Stroke + 30	Stroke + 20	Stroke + 3	Stroke + 24	Stroke + 15	Stroke + 13	Stroke + 28
G	30	37	40	37	58	73	58	180
H	24	30	35	30	55	65	55	125
I	45	55	65	55	110	115	110	405
J	16	19.5	24	19.5	39	43	39	145

The dimensions for these screw jacks are the same as the Anti-Backlash units except those detailed above.

## E-Series - Stainless Steel Screw Jacks - Anti-Backlash &amp; Anti-Rotation (Keyed) - Performance

Model		EMT0010-VKA EMT0010-JKA		EMT0025-VKA EMT0025-JKA		EMT0050-VKA EMT0050-JKA		EMT0100-VKA EMT0100-JKA		
Capacity	kN	10		25		50		100		
Sustaining Capacity (kN)	Tension	6.6		16.5		33		66		
	Compression	10		25		50		100		
Operating Capacity (kN)	Stainless Steel Worm Shaft		3.3		8.25		16.5		33	
	Plated Worm Shaft	Tension	6.6		16.5		33		66	
		Compression	10		25		50		100	
Lifting Screw <sup>1</sup>	mm		20		30		40		55	
	Lead	Option	1	2	1	2	1	2	1	2
		mm	5	10	6	12	9	18	12	24
Gear Ratios	Option 1		5:1		6:1		6:1		8:1	
	Option 2		20:1		24:1		24:1		24:1	
Max. Input Power (kW)	Gear Ratio Option 1		0.375		1.5		3.0		3.75	
	Gear Ratio Option 2		0.19		0.375		0.55		1.125	
Start up torque at full load (Nm) <sup>2</sup>	Gear Ratio Option 1		8.3	11.5	24.8	33	65.6	89.3	136	184
	Gear Ratio Option 2		3.8	5.3	10.3	13.7	30	40.9	70.3	95.2
Weight (kg) - stroke = 150mm		2.72		8.62		16.78		26.12		
Weight (kg) per extra 25mm		0.13		0.21		0.32		0.57		
Gear Ratio Option 1	Gear Ratio		5:1		6:1		6:1		8:1	
	Screw Jack Static Efficiency		0.193	0.277	0.161	0.241	0.182	0.267	0.176	0.259
	Screw Jack Dynamic Efficiency		0.250	0.346	0.211	0.306	0.239	0.338	0.231	0.330
Gear Ratio Option 2	Gear Ratio		20:1		24:1		24:1		24:1	
	Screw Jack Static Efficiency		0.104	0.149	0.097	0.145	0.100	0.146	0.113	0.167
	Screw Jack Dynamic Efficiency		0.151	0.209	0.142	0.206	0.146	0.208	0.163	0.233

Model		EMT0200-VKA EMT0200-JKA		EMT0300-VKA EMT0300-JKA		EMT0500-VKA EMT0500-JKA		EMT1000-VKA EMT1000-JKA		
Capacity	kN	200		300		500		1000		
Sustaining Capacity (kN)	Tension	132		200		333		666		
	Compression	200		300		500		1000		
Operating Capacity (kN)	Stainless Steel Worm Shaft		66		100		167		333	
	Plated Worm Shaft	Tension	132		200		333		666	
		Compression	200		300		500		1000	
Lifting Screw <sup>1</sup>	mm		65		95		120		160	
	Lead	Option	1	2	1	2	1	2	1	1
		mm	12	24	16	32	16	32	20	20
Gear Ratios	Option 1		8:1		10 2/3:1		10 2/3:1		12:1	
	Option 2		24:1		32:1		32:1		36:1	
Max. Input Power (kW)	Gear Ratio Option 1		3.75		6.0		11.25		18.5	
	Gear Ratio Option 2		1.125		1.9		4.5		8.25	
Start up torque at full load (Nm) <sup>2</sup>	Gear Ratio Option 1		296	387.9	562	723	1052	1301	2361	2361
	Gear Ratio Option 2		161.8	387.9	331	426	598	739	1309	1309
Weight (kg) - stroke = 150mm		49		91		209		610		
Weight (kg) per extra 25mm		0.86		1.58		2.49		4.31		
Gear Ratio Option 1	Gear Ratio		8:1		10 2/3:1		10 2/3:1		12:1	
	Screw Jack Static Efficiency		0.161	0.246	0.128	0.198	0.113	0.184	0.112	0.112
	Screw Jack Dynamic Efficiency		0.214	0.316	0.175	0.263	0.155	0.243	0.152	0.152
Gear Ratio Option 2	Gear Ratio		24:1		32:1		32:1		36:1	
	Screw Jack Static Efficiency		0.098	0.150	0.072	0.112	0.067	0.108	0.068	0.068
	Screw Jack Dynamic Efficiency		0.143	0.211	0.109	0.164	0.100	0.157	0.100	0.100

**Note**

1. All metric machine screws have a trapezoidal thread form.
2. For loads of 25% to 100% of screw jack capacity, torque requirements are approximately proportional to the load.
3. Efficiency values for standard grease lubricated worm gear box and lifting screw.
4. All E-Series screw jacks have grease lubricated gearbox and lead screw as standard.



## Extra Safety for Critical Applications

Power Jacks metric machine screw jacks can be fitted with a safety nut, which provides 2 safety roles:

1. In the event of excessive wear on the nut thread the load will be transferred from the standard nut to the safety nut. This will also provide visual wear indication as the gap between the safety nut decreases to zero as the standard lifting nut wears.
2. In the unlikely event of catastrophic nut thread failure the safety nut will sustain the load. The safety of industrial and human cargo is therefore improved.

There are several configurations for each safety nut device as they only work in one load direction. For this reason when ordering please supply a sketch of your application showing load directions.

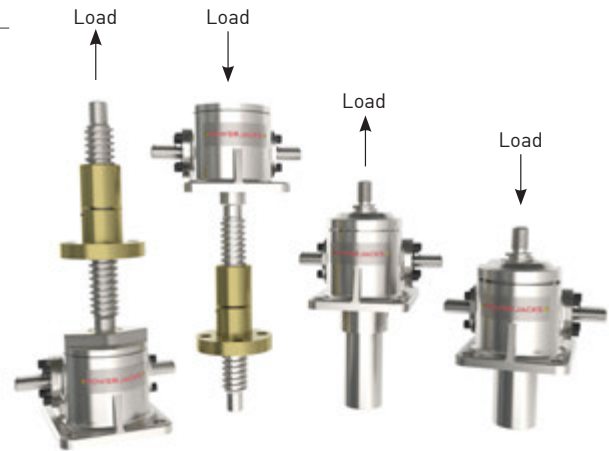

**All Safety Nuts are BS EN 1570 Compliant**

## Translating Screw Jacks with Safety Nuts

### Tension Safety Nut

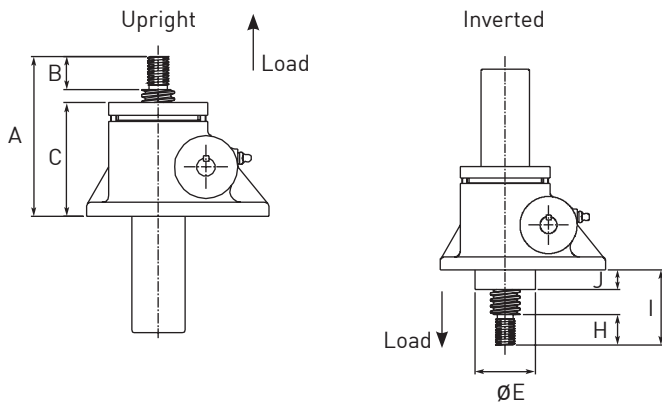

### Compression Safety Nut

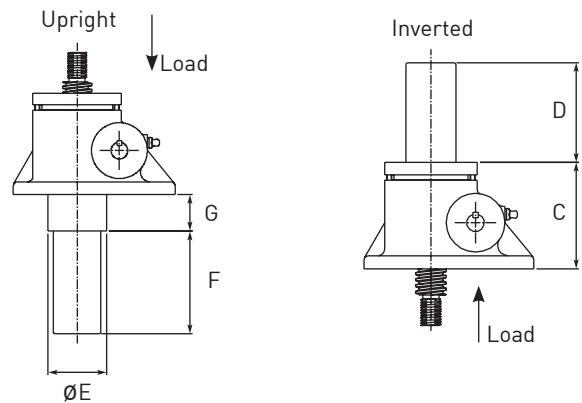

## Dimensions - Translating Screw

Model	Rating (kN)	A	B	C	D	ØE	F	G	H	I	J
EMT0010	10	125	24	86	Stroke + 35	38	Stroke + 9	30	24	45	16
EMT0025	25	145	30	104	Stroke + 30	60	Stroke + 30	37	30	55	20
EMT0050	50	185	35	138	Stroke + 20	75	Stroke + 20	40	35	65	24
EMT0100	100	200	40	146	Stroke + 3	90	Stroke + 28	48	40	80	30
EMT0200	200	265	55	195	Stroke + 24	102	Stroke + 24	58	55	110	39

Rotating Screw Jacks with Safety Nuts

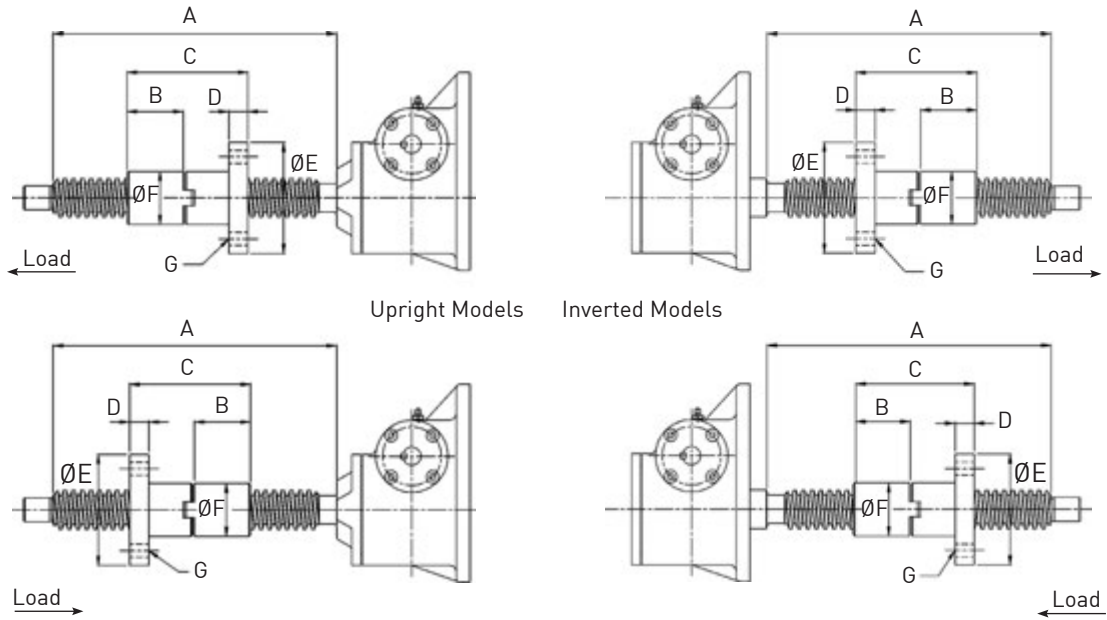

Dimensions - Rotating Screw

Model	Rating (kN)	A	B	C	D	ØE	ØF	G
EMR0010	10	Stroke + 76	30	66.5	12	80	35	4 x Ø11, Ø57 PCD
EMR0025	25	Stroke + 95	33.5	75	15	90	40	4 x Ø13.5, Ø65 PCD
EMR0050	50	Stroke + 140	58	125	20	115	55	4 x Ø18, Ø85 PCD
EMR0100	100	Stroke + 170	67	145	25	160	80	4 x Ø22, Ø120 PCD
EMR0200	200	Stroke + 170	67	145	25	185	90	4 x Ø26, Ø135 PCD
EMR0300	300	Stroke + 310	126	270	35	230	125	6 x Ø26, Ø175 PCD
EMR0500	500	Stroke + 335	130	284	50	280	160	6 x Ø33, Ø220 PCD
EMR1000	1000	Stroke + 410	155	335	60	380	210	6 x Ø45, Ø295 PCD

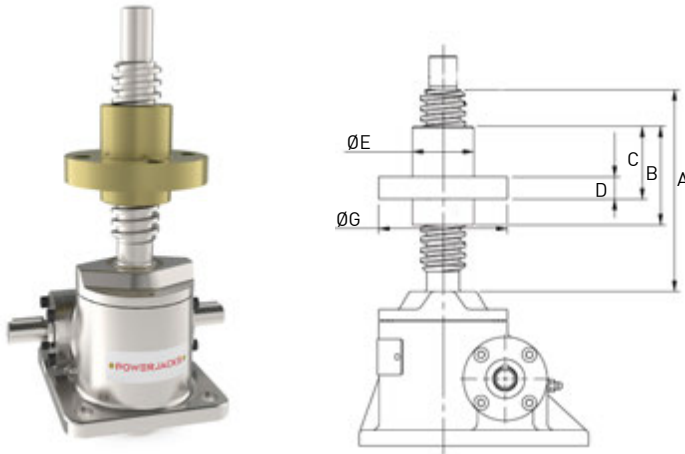

Model	A	B	C	D	ØE	F	ØG
EMR0010	Stroke + 61	52	35	12	35	4 x Ø11, Ø57 PCD	80
EMR0025	Stroke + 80	60	40	15	40	4 x Ø13.5, Ø65 PCD	90
EMR0050	Stroke + 100	85	65	20	55	4 x Ø18, Ø85 PCD	115
EMR0100	Stroke + 120	95	75	25	80	4 x Ø22, Ø120 PCD	160
EMR0200	Stroke + 120	95	75	25	90	4 x Ø26, Ø135 PCD	185
EMR0300	Stroke + 200	160	140	35	125	6 x Ø26, Ø175 PCD	230
EMR0500	Stroke + 225	175	150	50	160	6 x Ø33, Ø220 PCD	280
EMR1000	Stroke + 275	200	175	60	210	6 x Ø45, Ø295 PCD	380

### Secondary Guide - Greater Lateral Rigidity for Lifting Screw

Secondary Guiding for the screw for greater lateral rigidity aiding screw guidance and improved side load resilience.

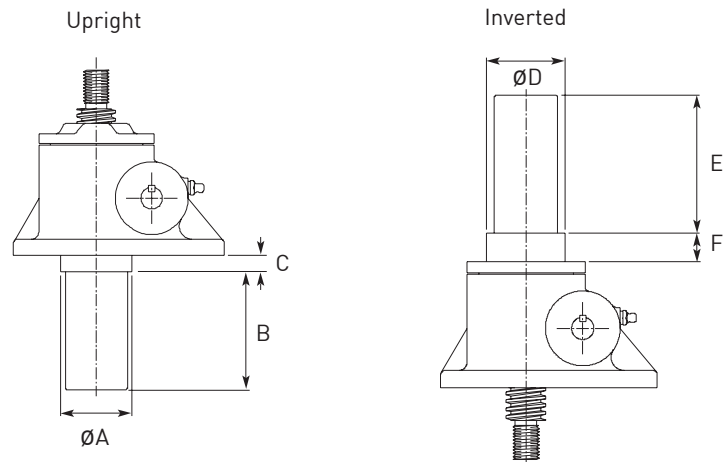

### Dimensions for Screw Jacks with Secondary Guides

Model	EMT0010	EMT0025	EMT0050	EMT0100	EMT0200	EMT0300	EMT0500	EMT1000	
Upright	ØA	38	60	70	90	100	138	155	225
	B	Stroke + 34	Stroke + 30	Stroke + 20	Stroke + 29	Stroke + 24	Stroke + 40	Stroke + 38	Stroke + 50
	C	20	20	18	20	20	38	38	65
Inverted	ØD	N/A	60	70	90	100	138	155	On Request
	E	Stroke + 34	Stroke + 30	Stroke + 20	Stroke + 29	Stroke + 24	Stroke + 40	Stroke + 38	
	F	N/A	20	18	20	20	38	38	

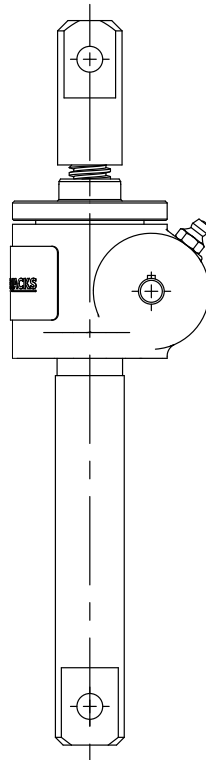

Style 1

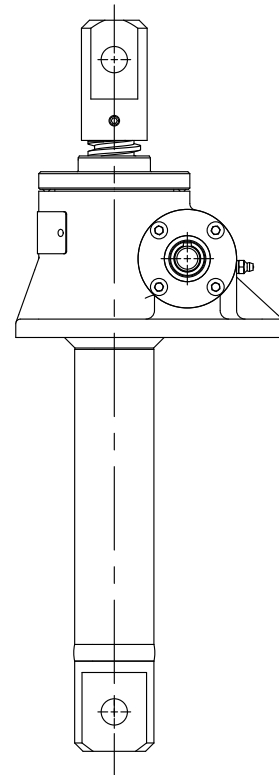

Style 2

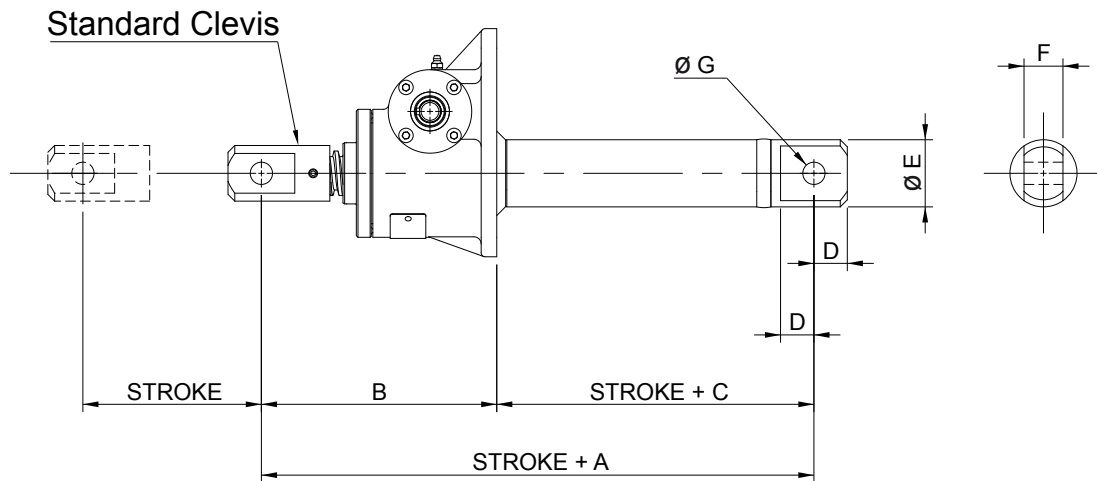

Model	EMT0010	EMT0025	EMT0050	EMT0100	EMT0200	EMT0300	EMT0500	EMT1000
Capacity (kN)	10	25	50	100	200	300	500	1000
Style	1	2	2	2	2	2	2	On Request
A	180	213	260	352	428	492	570	
B	145	170	210	247	313	367	440	
C	35	43	50	105	115	125	130	
D	20	23	30	33	40	60	75	
E	33.4	48.3	60.3	73	102	133	168	
F	20	30	35	40	50	80	110	
ØG	12	16	20	22	30	45	60	
Max Stroke at Rated Load (Compression)	175	352	420	593	592	1338	1920	

Note: All dimensions in millimetres unless otherwise stated.

E-Series

5

## E-Series Ball Screw Jack

**HIGH EFFICIENCY BALL  
SCREW JACK IN A COMPACT  
DESIGN WITH INTEGRATED  
SAFETY DEVICE.**

Overall operating efficiency is as high as 70% in some models, depending on the worm gear ratio.

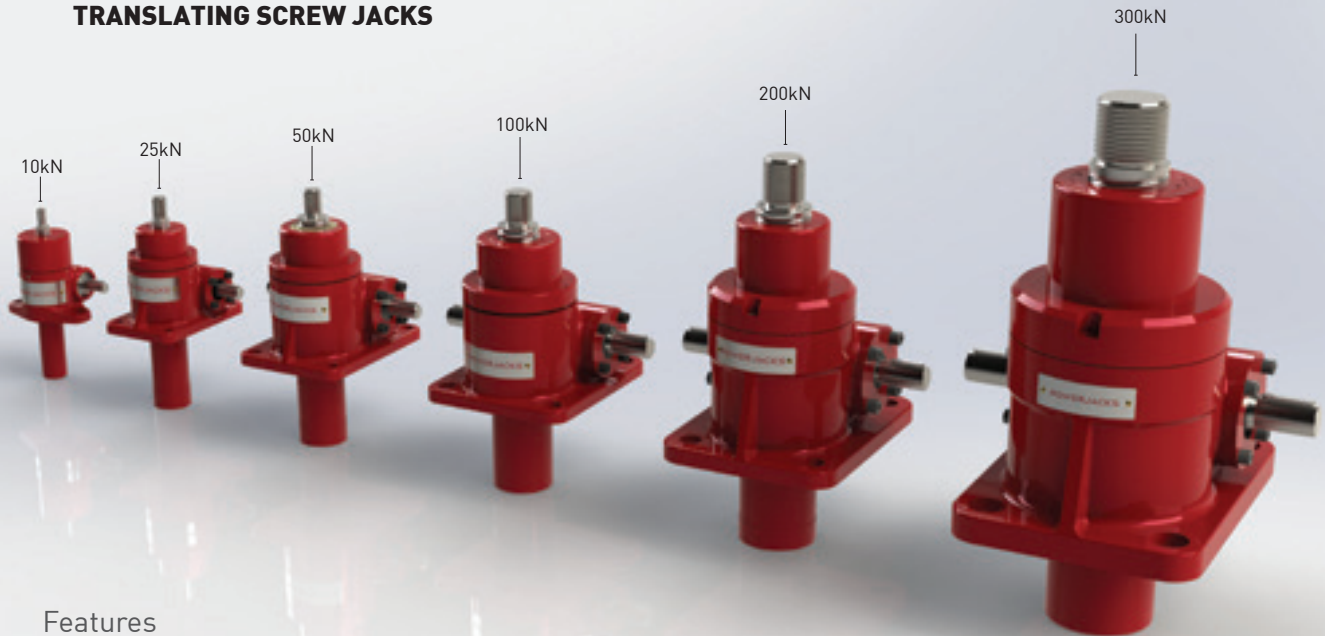
**TRANSLATING SCREW JACKS****Features**

- High Efficiency Power Jack
- Metric Single Face Ball Screw Jacks
- Capacities - 10kN to 300 kN as standard
- Integral Safety Device for 25kN & above as standard
- Translating and Rotating Screw in Upright and Inverted types
- Precision Worm Gear Set and Ball Screw Drive
- 2 Gear ratios and 2 screw leads as standard
- Pre-loaded and Anti-rotation ball screw options
- 6 mounting options including trunnion and double clevis
- Special custom designs available

**ROTATING SCREW JACKS**

## End Fittings as Standard

1. Top Plate (shown)
2. Clevis End
3. Fork End
4. Rod End

Threaded end on screw as standard. End fittings screw on.

**Bellows Boot**  
Screw protection prevents ingress of dirt and debris onto screw threads.

## End Cap

Protective cap for ball nut with guide for ball screw.

**Ball Nut**  
Internal continuous recirculation of steel balls. Threaded and secured to worm gear. Equipped with INTEGRAL SAFETY DEVICE.

## Ball Screw

Standard with threaded end.

## Load Bearings

Top and bottom to take loads in either direction.

## Worm Shaft

Available with double or single shaft extension. In standard, plated or stainless steel material.

Accurately hobbled aluminium bronze worm gear for greater gear contact.

## Housing

Aluminium on 10 kN model. Ductile iron on 25 kN through 100 kN models, cast steel on 200 kN through 500 kN models.

Thrust Bearings and Grease Seals at each end of worm. 10kN version does not have separate seal.

Mounting Bolt Holes.

## Cover Pipe

Protects Lifting Screw Threads.

Corrosion Protection to suit all economic needs including:

- Standard Industrial Paint
- Arduous Environment Paint
- Customer Specified Paint
- Plated Finish

Grease Application Point.



### Translating Screw



Upright

Inverted

### Rotating Screw



Upright

Inverted

## Typical Applications

Ball Screw Jacks are generally used when the application has a relatively high duty cycle or the input power for a given screw jack is to be minimised. The high efficiency of the ball screw & nut significantly increase the efficiency of a screw jack in comparison to a Machine Screw Jack. Due to their high efficiency they nearly always require a brake to hold position. They are used in a wide variety of applications including Automotive, Steel, Glass, Defence, Nuclear and Solar industries.

## Standard Designs

The standard E-Series ball screw jack is available in translating and rotating screw designs in capacity sizes from 10kN to 500kN. The design is optimised for performance and a compact form, which includes an added safety device as standard for most models. There is a large selection of options and accessories (section-7) that allows you to configure a standard design that is just right for your application. These options include Zero-Backlash and Anti-Rotation designs.

## Special Designs

We can fully customise our screw jacks so that your application can be the best.

Customisation can be anything from a small modification such as an extra bolt hole on an end fitting to a completely new design of screw jack based on our class leading technology.

For more details please see the Special Screw Jack information in Section-8 or contact us today with your requirements. Our team are looking forward to working with you.

## Selecting the Right Screw Jack

Consider all application constraints then choose a product that looks suitable for the intended application. Calculate the power and torque requirements. This is a 5 step process:

- Screw Jack Input Speed (RPM)
- Operating Input Power (kW)
- Operating Input Torque (Nm)
- Screw Jack Start-up Torque (Nm)
- Mechanical Power and Torque Check

## Systems

The screw jacks can be connected together in systems so that multiple units can be operated and controlled together. These jacking system arrangements or configurations can be built in many formats with the use of bevel gearboxes, motors, reduction gearbox, drive shafts, couplings, plummer blocks and motion control devices.

The use of bevel gearboxes allows the distribution of drive throughout a jacking system. The gearboxes come in 2,3 and 4 way drive types. See the Bevel Gearbox Section-10 for more details.

Bevel gearboxes and other system components can also be supplied in stainless steel or other corrosion resistant designs.

Two of the most popular system configurations are the 'H' and 'U' configured jacking systems. Remember that multiple screw jacks can be linked together mechanically or electrically. The latter is useful if there is no space for linking drive shafts.



If multiple ball screw jacks are connected in a mechanically linked system then the complete system in some designs may be considered self-locking. If you would like this checked consult Power Jacks. Alternatively, to be sure, include a brake on the system either as a stand alone device or as a brake motor.



## CAVENDISH LABORATORY ANTENNA DISH

Position adjustment of Arcminute Microkelvin Imager (AMI) to achieve a pointing accuracy of better than half a minute of arc (1/120 of a degree). 10 x antenna dishes all in close proximity of each other. Measuring the weight of the universe by analysing "dark matter".

10 x off 50kN E-Series special metric ball screw jacks based on EBT0050 in translating screw configuration with a stroke of 1050mm. These ball screw jacks operate in normal UK outdoor conditions and allow the antenna to operate at wind speeds of up to 50mph.

For more application examples see the 'Power at Work' brochure or [www.powerjacks.com](http://www.powerjacks.com).



## Screw Jack Standard Performance

Model		EBT0010 EBR0010	EBT0025 EBR0025		EBT0050 EBR0050		EBT0100 EBR0100		EBT0200 EBR0200		EBT0300 EBR0300	EBT0500 EBR0500
Capacity (kN)		10	25		50		100		200		300	500
Lifting Screw	Diameter (mm)		20	25		40		50		63		80
	Lead	Option	1	1	2	1	2	1	2	1	2	1
		Lead (mm)	5	5	10	10	20	10	20	10	20	20
Gear Ratios	Option 1		5:1	6:1		6:1		8:1		8:1		10 2/3:1
	Option 2		20:1	24:1		24:1		24:1		24:1		32:1
Turn of worm for travel of Lifting Screw	Option 1	6 Turn	6mm	5mm	10mm	10mm	20mm	7.5mm	15mm	7.5mm	15mm	11.25mm
	Option 2	24 Turn	6mm	5mm	0mm	10mm	20mm	10mm	20mm	10mm	20mm	7.5mm
Maximum Input Power (kW)	Gear Ratio Option 1		0.375	1.5		3		3.75		3.75		6.0
	Gear Ratio Option 2		0.19	0.375		0.55		1.125		1.125		1.9
Start-up Torque at full load (Nm) †	Gear Ratio Option 1		2.7	5.9	11.1	23.4	44.6	36.4	68.5	75.2	139.4	182
	Gear Ratio Option 2		1.2	2.6	4.9	10.7	20.4	19.1	35.8	39.4	72.9	107.3
Maximum Through Torque (Nm)		20	59		168		347		396		1440	
Lead Screw Restraining Torque (Nm)		9	23	43	88	167	181	340	370	690	1030	
Worm Shaft Maximum Radial Load (N)		325	380		740		1000		1600		2170	
Maximum Input Speed (rpm)		1800	1800		1800		1800		1800		1800	
Gear Case Material		Aluminium	SG Iron		SG Iron		SG Iron		Steel		Steel	
Weight (kg) - stroke = 150mm	EMT	2.36	8.45		14.9		24.3		42.4		92.4	
	EMR	2.6	8.85		16.54		28.8		49.58		113.78	
Weight (kg) - per extra 25mm	EMT	0.11	0.21		0.32		0.58		0.84		1.55	
	EMR	0.05	0.11		0.19		0.36		0.52		1.13	
Ball Nut Safety Device		On Request	Standard		Standard		Standard		Standard		On Request	

On Request

† For loads of 25% to 100% of screw jack capacity, torque requirements are approximately proportional to the load.

## Efficiency - Option 1 Gear Ratio

Model	EBT0010 EBR0010	EBT0025 EBR0025		EBT0050 EBR0050		EBT0100 EBR0100		EBT0200 EBR0200		EBT0300 EBR0300	EBT0500 EBR0500
Gear Ratio	5:1	6:1		6:1		8:1		8:1		10 2/3:1	
Lifting Screw Lead (mm)	5	5	10	10	20	10	20	10	20	20	
Static Efficiency	0.603	0.565	0.600	0.567	0.595	0.546	0.581	0.529	0.571	0.492	
Dynamic Efficiency	0.681	0.662	0.692	0.663	0.687	0.645	0.674	0.631	0.665	0.595	

On Request

## Efficiency - Option 2 Gear Ratio

Model	EBT0010 EBR0010	EBT0025 EBR0025		EBT0050 EBR0050		EBT0100 EBR0100		EBT0200 EBR0200		EBT0300 EBR0300	EBT0500 EBR0500
Gear Ratio	20:1	24:1		24:1		24:1		24:1		32:1	
Lifting Screw Lead (mm)	5	5	10	10	20	10	20	10	20	20	
Static Efficiency	0.341	0.320	0.340	0.310	0.325	0.348	0.370	0.337	0.364	0.278	
Dynamic Efficiency	0.429	0.419	0.438	0.407	0.422	0.450	0.470	0.440	0.465	0.371	

On Request

## Note

1. Efficiency values for standard grease lubricated worm gear box and lifting screw.

Power Jacks ball nut employs the internal ball transfer system for recirculating the balls. This design provides for:

- Robust design
- Small ball nut body outer diameter
- Smooth movement
- Less turns per circuit
- Absence of parts liable to wear.

Solid formed nylon wiper seals on the ball nut prevents ingress of foreign matter and retain lubrication within the nut.

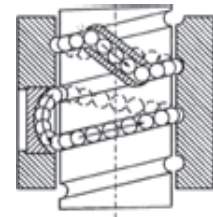

Standard

## Ball Screw Life

Theoretical service life can be expressed in either  $L_{10}$   $10^6$  revolutions or  $L_h$   $10^3$  hours or  $L_d$  kilometres. As the life of a ball screw is determined by metal fatigue it is not possible to accurately predict life. However, it is practical to suppose that 90% of a sufficiently large number of equally sized ball screws running under equal working conditions will reach  $L_{10}$  or  $L_h$  without evidence of material fatigue. The  $L_{10}$  ball screw life is rated using the Dynamic Capacity, which is the maximum constant axial load that can be applied in running conditions for a life of  $1.10^6$  revolutions of the ball screw. This can be expressed in linear travel ( $L_d$ ).

Where  $L_{10}$  = Service Life (millions of revolutions)  
 $L_d = L_{10} * P$   $L_d$  = Service Life (km)  
 $P$  = Pitch of Ball Screw (mm)

Linear Travel $L_d$ in km			Working Load (kN)										
Model	Capacity (kN)	Pitch (mm)	5	10	25	30	50	75	100	150	200	250	300
E28501	10	5	20.5	2.5	-	-	-	-	-	-	-	-	-
E3802	25	5	381	48	3	-	-	-	-	-	-	-	-
E38021	25	10	1 775	222	14	-	-	-	-	-	-	-	-
E3805	50	10	11 978	1 497	96	55	12	-	-	-	-	-	-
E38051	50	20	17 039	2 130	136	79	17	-	-	-	-	-	-
E3810	100	10	32 287	4 036	258	149	32	10	4	-	-	-	-
E38101	100	20	38 503	4 813	308	178	39	11	5	-	-	-	-
E3820	200	10	162 327	20 291	1 299	752	162	48	20	6	3	-	-
E38201	200	20	320 060	40 008	2 560	1 482	320	95	40	12	5	-	-
E3830	300	20	903 882	112 985	7 231	4 185	904	268	113	33	14	7	4

Use the following formulae to calculate the service life in terms of hours running:

Where  $L_h$  = Service Life (hours)  
 $L_{10}$  = Service Life (revolutions)  
 $n_m$  = Mean Screw Jack Input Speed (rpm)  
 $Gr$  = Gear Ratio

$$L_h = \frac{L_{10} * Gr}{60 * n_m}$$

**Note:** 1. Ball screw life based on dynamic load calculated according to DIN69051 Part 4.

## Extra Safety As Standard with Integral Safety Device

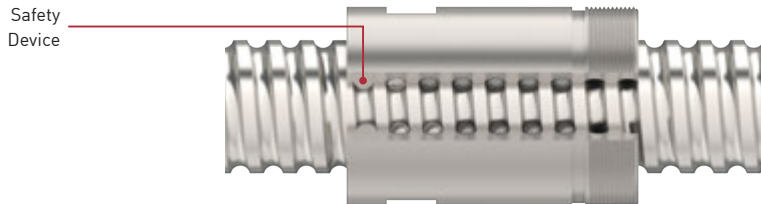

25kN TO 200kN Power Jacks Metric Ball Screw Jacks have an integral safety device as standard. This provides two important safety roles:

1. In the unlikely event of an excessive wear in the ball screw drive, the safety device will contact the screw shaft and act as an "ACME" Thread. This will provide early warning of any possible ball screw failure and is capable of providing drive in the event of any such failure. This can allow a control system to alert an operator to wear of this kind by monitoring the increase in motor current required to drive the system due to the increased friction generated by the device.
2. It allows the ball nut on the screw jack to sustain a load in the event of catastrophic ball failure. The safety of industrial and human cargo is therefore improved. Ball screw systems without this device could collapse under load or drop the carried load.

**Note:** Model 10kN & 300kN ball screw jack does not have safety device as standard, if required consult Power Jacks Ltd.

## Optimal Ball Nut Alignment & Load Capability

Better by Design Power Jacks Ball Screw Jacks mount the upper load bearing directly on top of the gear the same as all other screw jacks in our range.

Advantages:

- A. Compact Design
- B. Optimum Gear Holding & Accuracy



**BETTER BY DESIGN**

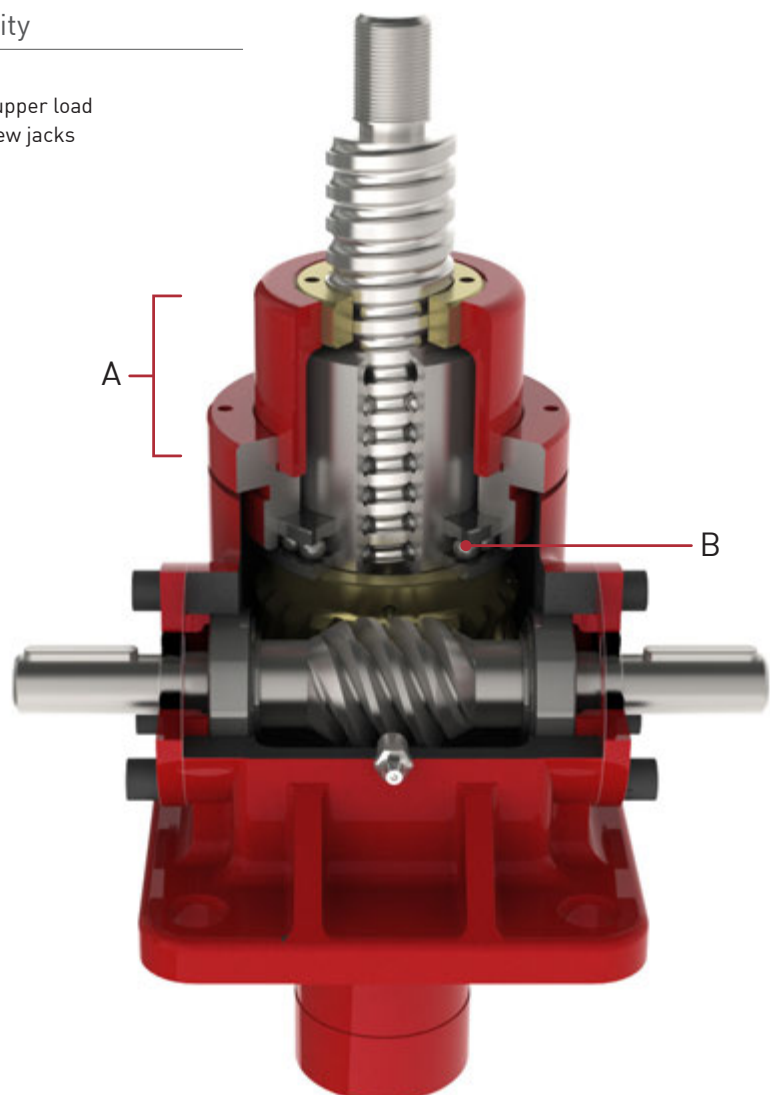



Upright EBT0010-U00

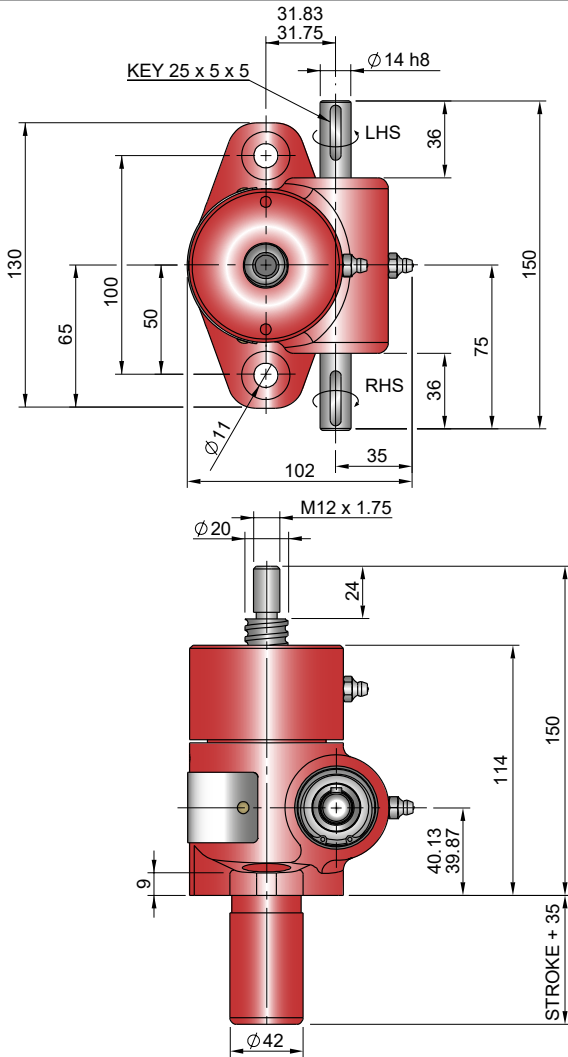

Inverted EBT0010-I00

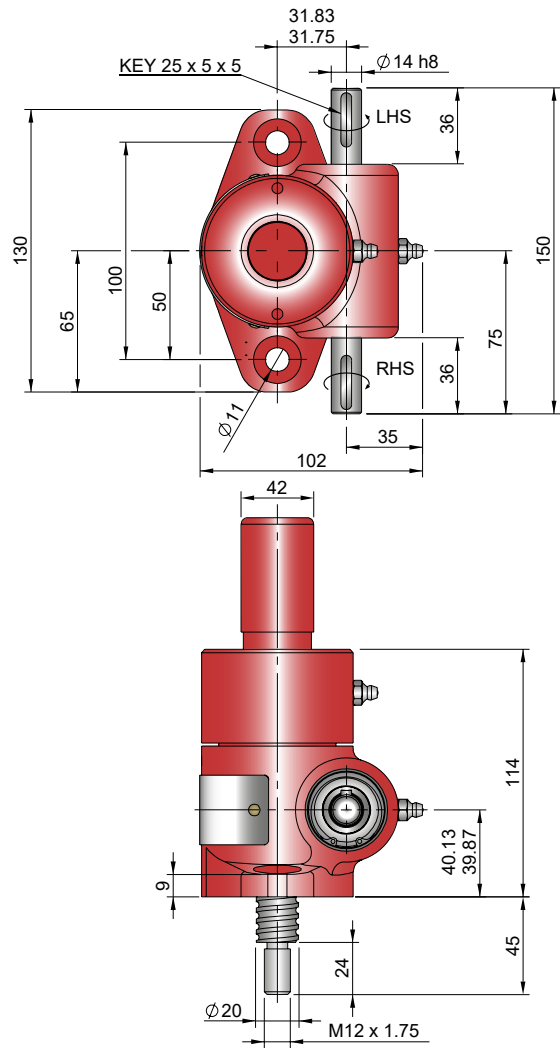

Performance

Closed Height

Model		EBR0010 EBT0010
Capacity	kN	10
Lifting Screw	Diameter (mm)	20
	Lead	Option 1 mm
Gear Ratio Option 1	Option	1
	mm	5
	Gear Ratio	5:1
Gear Ratio Option 2	Static Efficiency	0.603
	Dynamic Efficiency	0.681
Gear Ratio Option 2	Gear Ratio	20:1
	Static Efficiency	0.341
	Dynamic Efficiency	0.429
Max. Input power (kW)	Gear Ratio Option 1	0.375
	Gear Ratio Option 2	0.18
Start up torque at full load (Nm)	Gear Ratio Option 1	2.7
	Gear Ratio Option 2	1.2

Model		EBR0010 EBT0010
Capacity	kN	10
Lifting Screw Lead (mm)		5
Turn of worm for travel of lifting screw	Gear Ratio 1	6 Turn
	Gear Ratio 2	24 Turn
Maximum Through Torque (Nm)		20
Lifting Screw Restraining Torque (Nm)		9
Worm Shaft Maximum Radial Load (N)		325
Maximum Input Speed (rpm)		1800
Gear Case Material		Aluminium
Weight (kg) - stroke = 150mm	EMT	2.36
	EMR	2.6
Weight (kg) - per extra 25mm stroke	EMT	0.11
	EMR	0.05

Note: All dimension in millimetres unless otherwise stated.  
Designs subject to change without notice

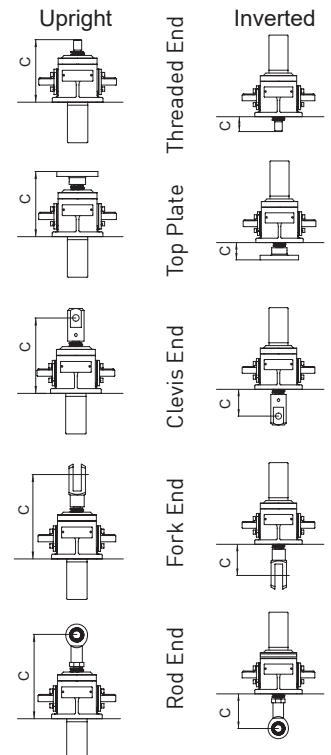

### Upright EBR0010-U00

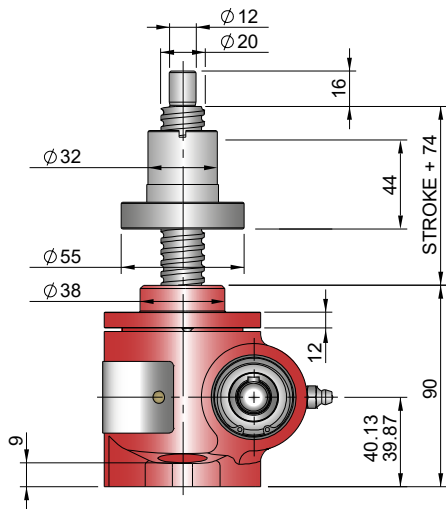
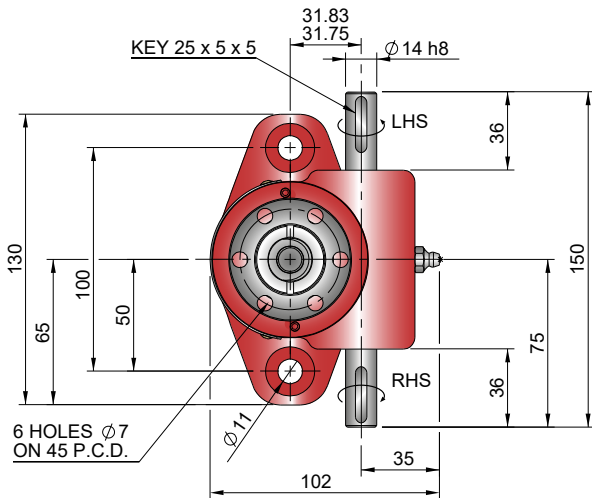

### Inverted EBR0010-I00

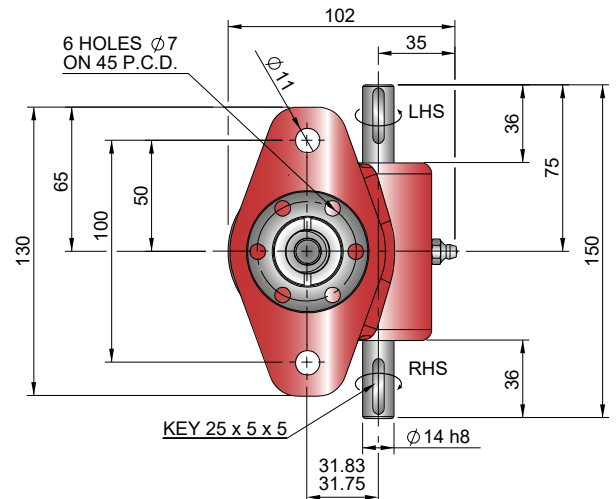
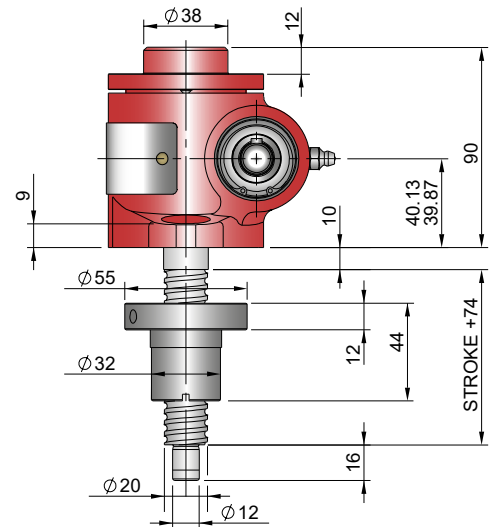

### Closed Height & Bellows Boots

Closed Height "C"	Threaded End		Top Plate		Clevis End		Fork End		Rod End	
	Upright	Inverted	Upright	Inverted	Upright	Inverted	Upright	Inverted	Upright	Inverted
EBT0010	125	45	125	45	145	65	148	98	150	70
Stroke (mm)	EBT0010 with Bellows Boots									
1-300	166	61	166	61	186	81	189	84	209	104
301-600	182	77	182	77	202	97	205	100	225	120
601-1050	206	101	206	101	226	121	229	124	249	144
1051-1500	230	125	230	125	250	145	253	148	273	168

Model	A	B	D	E	G
EBT0010	30	70	12	12	114

Stroke	1-300	301-600	601-1050	1051-1500
EBT0010	16	32	56	80

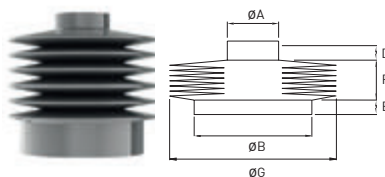

### Column Strength

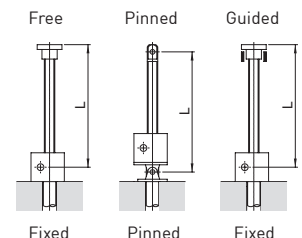
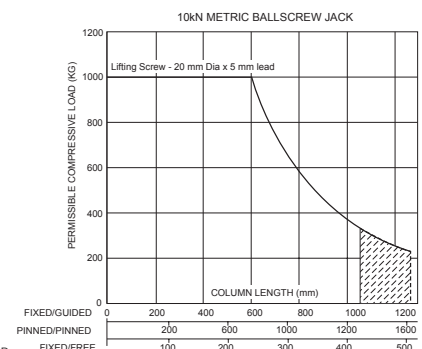

- Note:
- 1 Inverted Screw Jacks - Bellows Boot Closed Height assumes screw jack mounted on a structure with thickness = 10mm
  - 2 Inverted Screw Jacks - Recommended bellows boot mounting plate  $\text{ØB} \times [\text{E} + 5\text{mm}]$  thick.
  - 3 Inverted Screw Jacks - Screw Jack mounting plate & bellows boot mounting plate are customers own supply
  - 4 † Control tapes fitted (increase outer diameter by 20mm approximately).
  - 5 For horizontal installations with than 450 mm of stroke, internal boot guides are recommended.
  - 6 Customers with threaded end screw jacks must provide a fixing for the unattached bellows boot collar.
  - 7 Bellows boots for Rotating Screw Jacks, other sizes, stroke and materials please consult Power Jacks.



Upright EBT0025-U00

Inverted EBT0025-I00

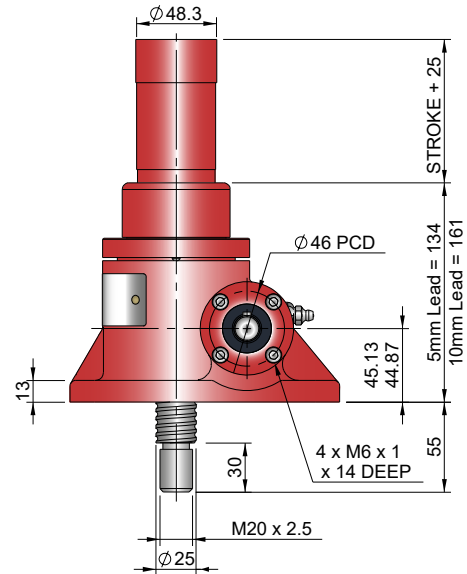
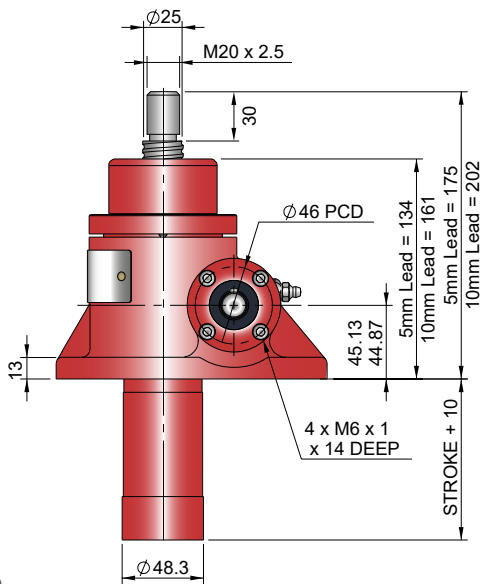
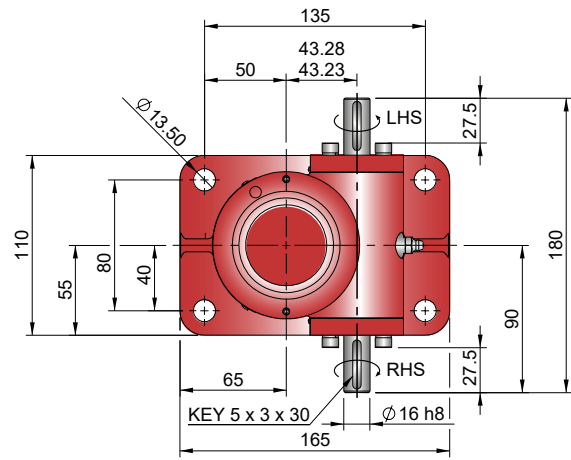
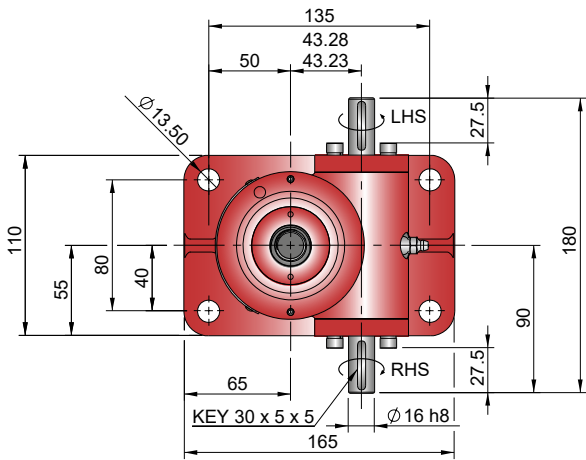

Performance

Closed Height

Model		EBT0025 EBR0025	
Capacity	kN	25	
Lifting Screw	Diameter (mm)	25	
	Lead	Option	1   2
		mm	5   10
Gear Ratio Option 1	Gear Ratio	6:1	
	Static Efficiency	0.565	0.600
	Dynamic Efficiency	0.662	0.692
Gear Ratio Option 2	Gear Ratio	24:1	
	Static Efficiency	0.320	0.340
	Dynamic Efficiency	0.419	0.438
Max. Input power (kW)	Gear Ratio Option 1	1.5	
	Gear Ratio Option 2	0.375	
Start up torque at full load (Nm)	Gear Ratio Option 1	5.9	11.1
	Gear Ratio Option 2	2.6	4.9

Model		EBT0025 EBR0025	
Capacity	kN	25	
Lifting Screw Lead (mm)		5	10
Turn of worm for travel of lifting screw	Gear Ratio 1	6 Turn	5mm   10mm
	Gear Ratio 2	24 Turn	5mm   10mm
Maximum Through Torque (Nm)		59	
Lifting Screw Restraining Torque (Nm)		23	43
Worm Shaft Maximum Radial Load (N)		380	
Maximum Input Speed (rpm)		1800	
Gear Case Material		SG Iron	
Weight (kg) - stroke = 150mm	EMT	8.45	
	EMR	8.85	
Weight (kg) - per extra 25mm stroke	EMT	0.21	
	EMR	0.11	

Note: All dimension in millimetres unless otherwise stated.  
Designs subject to change without notice

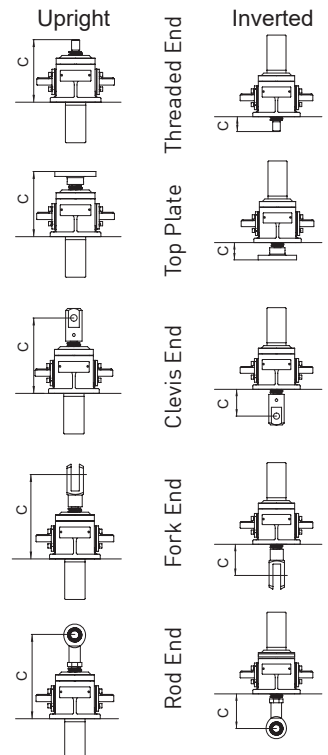

## Upright EBR0025-U00

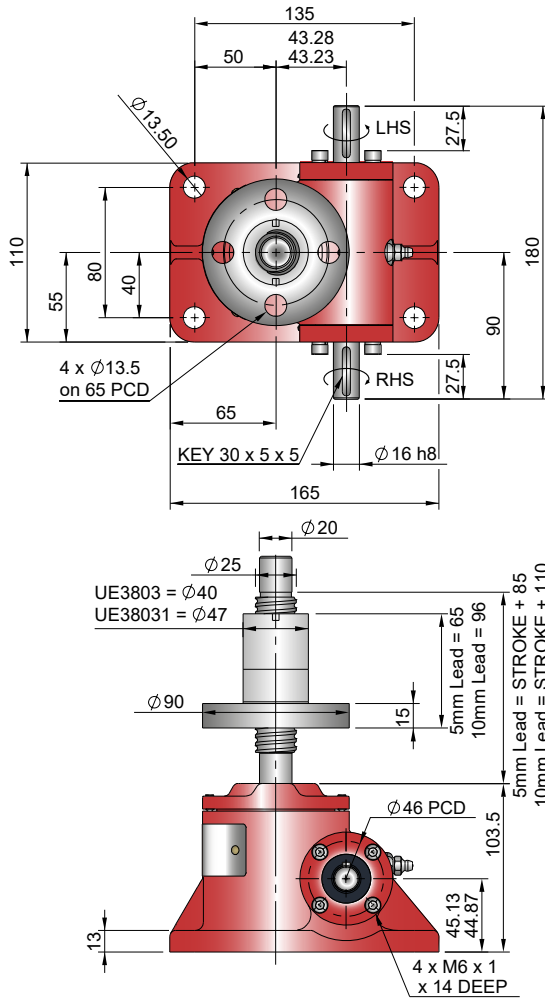

## Inverted EBR0025-I00

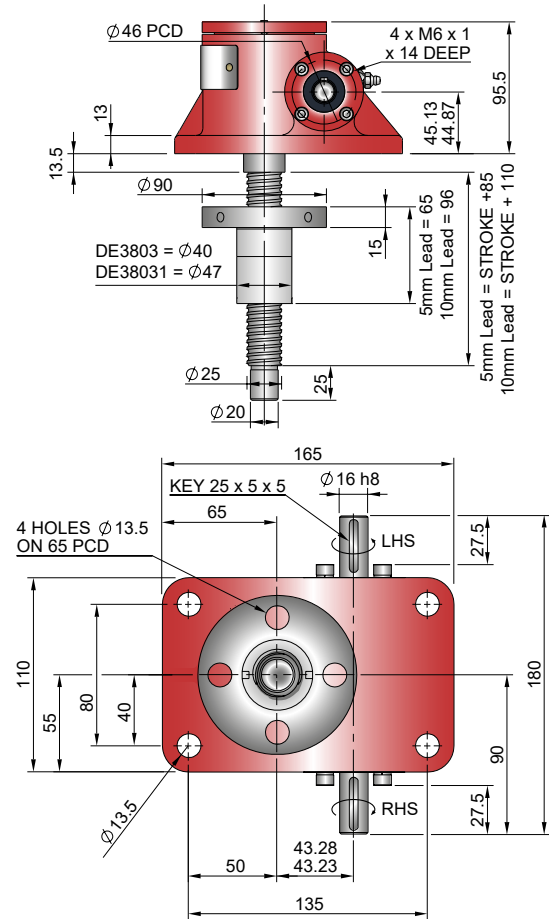

## Closed Height & Bellows Boots

Closed Height "C"	Threaded End		Top Plate		Clevis End		Fork End		Rod End						
	Upright	Inverted	Upright	Inverted	Upright	Inverted	Upright	Inverted	Upright	Inverted					
EBT0025	145	55	145	55	170	80	194	104	190	100					
Stroke (mm)	EBT0025 with Bellows Boots														
Lead (mm)	5	10	5 & 10	5	10	5 & 10	5	10	5 & 10	5	10	5 & 10			
1-300	180	200	100	180	200	100	205	225	125	229	249	149	240	260	160
301-600	190	210	110	190	210	110	215	235	135	239	259	159	250	270	170
601-1050	210	230	130	210	230	130	235	255	155	259	279	179	270	290	190
1051-1500	230	250	150	230	250	150	255	275	175	279	299	199	290	310	210

Model	A	B	D	E	G
EBT0025	40	66	15	15	120

Stroke	1-300	301-600	601-1050	1051-1500
EBT0025	20	30	50	70

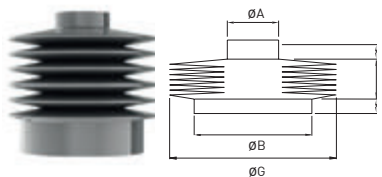

## Column Strength

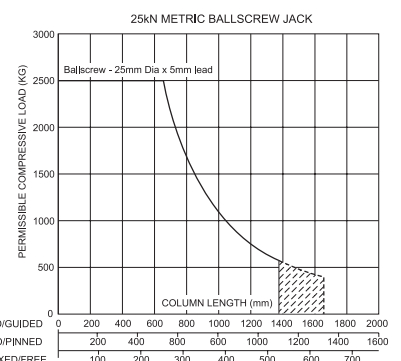

Note: For 25mm Dia x 10mm lead column strength chart refer to Engineering Guide

Note:

- 1 Inverted Screw Jacks - Bellows Boot Closed Height assumes screw jack mounted on a structure with thickness = 10mm
- 2 Inverted Screw Jacks - Recommended bellows boot mounting plate ØB x (E +5mm) thick.
- 3 Inverted Screw Jacks - Screw Jack mounting plate & bellows boot mounting plate are customers own supply
- 4 † Control tapes fitted (increase outer diameter by 20mm approximately).
- 5 For horizontal installations with than 450 mm of stroke, internal boot guides are recommended.
- 6 Customers with threaded end screw jacks must provide a fixing for the unattached bellows boot collar.
- 7 Bellows boots for Rotating Screw Jacks, other sizes, stroke and materials please consult Power Jacks.

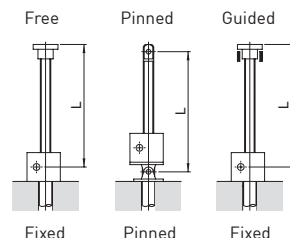

**Upright EBT0050-U00**

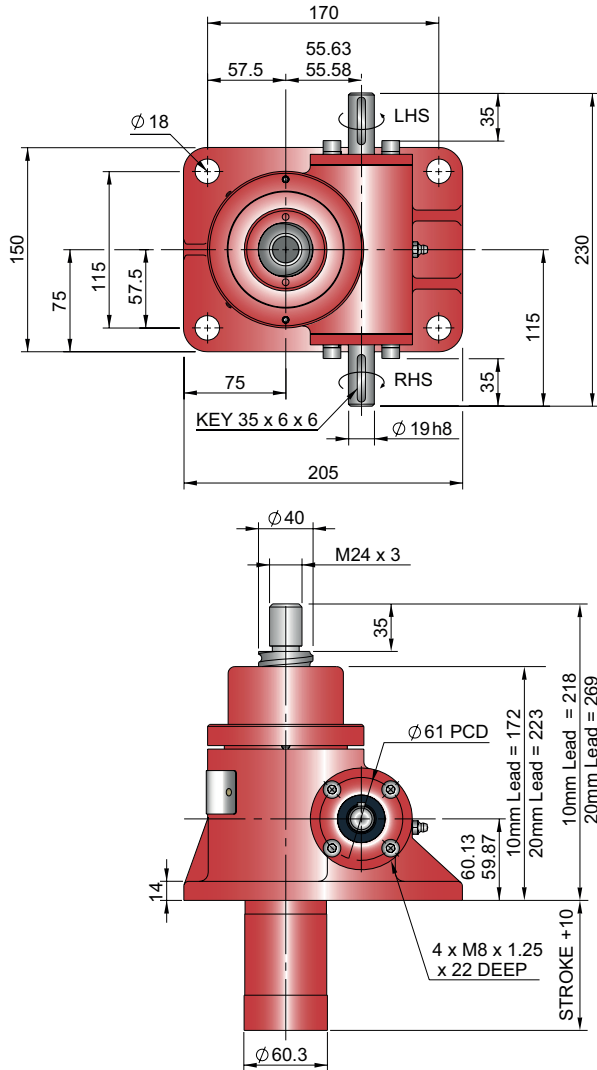

**Inverted EBT0050-I00**

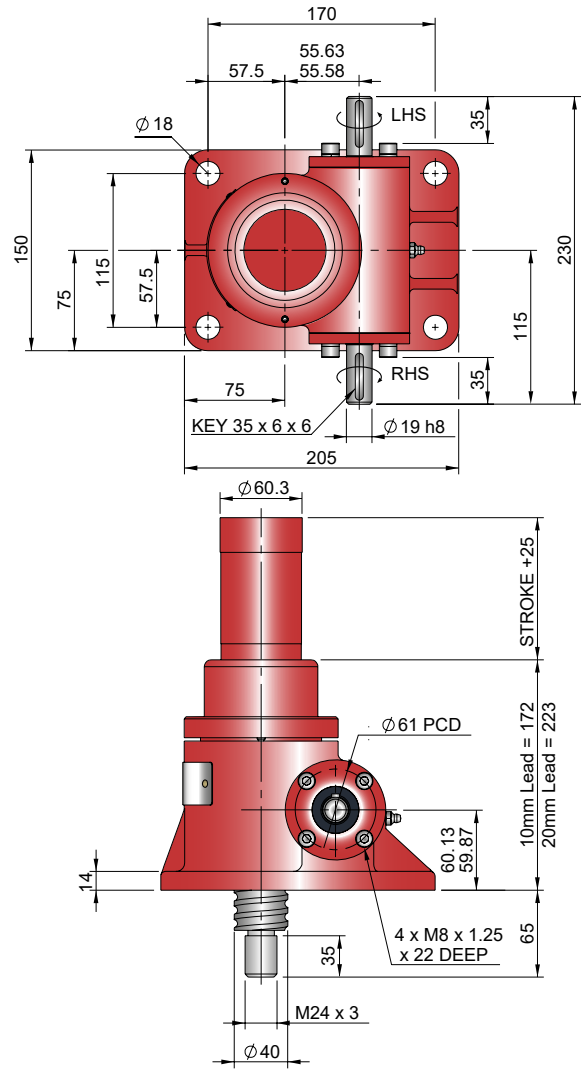

**Performance**

**Closed Height**

Model		EBT0050 EBR0050	
Capacity	kN	50	
Lifting Screw	Diameter (mm)	40	
	Lead	Option	1   2
		mm	10   20
Gear Ratio Option 1	Gear Ratio	6:1	
	Static Efficiency	0.567	0.595
	Dynamic Efficiency	0.633	0.687
Gear Ratio Option 2	Gear Ratio	24:1	
	Static Efficiency	0.310	0.325
	Dynamic Efficiency	0.407	0.422
Max. Input power (kW)	Gear Ratio Option 1	3.0	
	Gear Ratio Option 2	0.55	
Start up torque at full load (Nm)	Gear Ratio Option 1	23.4	44.6
	Gear Ratio Option 2	10.7	20.4

Model		EBT0050 EBR0050	
Capacity	kN	50	
Lifting Screw (mm)		10	20
Turn of worm for travel of lifting screw	Gear Ratio 1	6 Turn	10mm   20mm
	Gear Ratio 2	24 Turn	10mm   20mm
Maximum Through Torque (Nm)		168	
Lifting Screw Restraining Torque (Nm)		88	167
Worm Shaft Maximum Radial Load (N)		740	
Maximum Input Speed (rpm)		1800	
Gear Case Material		SG Iron	
Weight (kg) - stroke = 150mm	EMT	14.9	
	EMR	16.54	
Weight (kg) - per extra 25mm stroke	EMT	0.32	
	EMR	0.19	

Note: All dimension in millimetres unless otherwise stated.  
Designs subject to change without notice

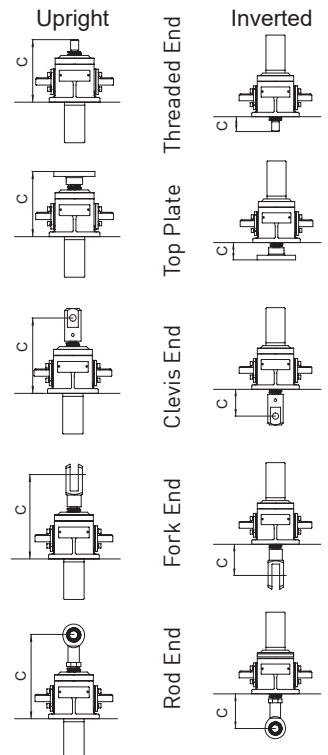

## Upright EBR0050-U00

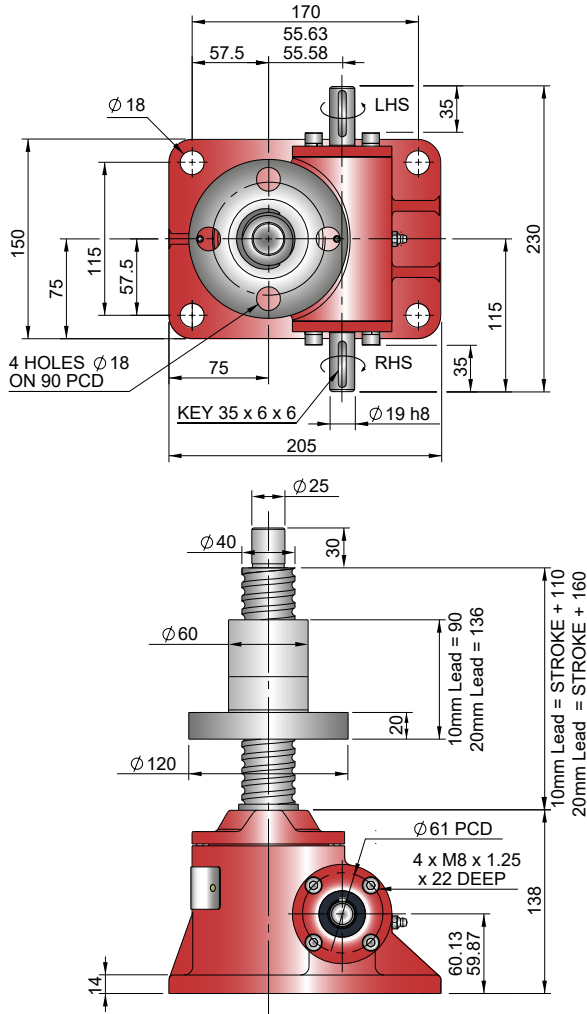

## Inverted EBR0050-I00

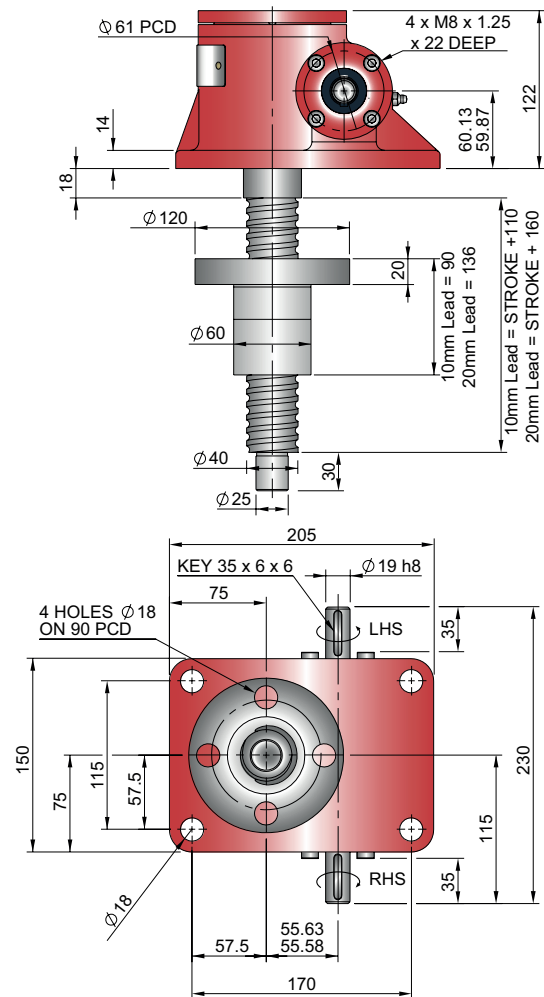

## Closed Height & Bellows Boots

Closed Height "C"	Threaded End		Top Plate		Clevis End		Fork End		Rod End						
	Upright	Inverted	Upright	Inverted	Upright	Inverted	Upright	Inverted	Upright	Inverted					
EBT0050	185	65	185	65	210	90	248	128	242	122					
Stroke (mm)	EBT0050 with Bellows Boots														
Lead (mm)	10	20	10 & 20	10	20	10 & 20	10	20	10 & 20	10	20	10 & 20	10	20	10 & 20
1-300	230	270	105	230	270	105	255	295	130	293	333	168	302	342	177
301-600	240	280	115	240	280	115	265	305	140	303	343	178	312	352	187
601-900	255	295	130	255	295	130	280	320	155	318	358	193	327	367	202
900-1050	260	300	135	260	300	135	285	325	160	323	363	198	332	372	207
1051-1500	280	320	155	280	320	155	305	345	180	343	383	218	352	392	227

Model	A	B	D	E	G
EBT0050	50	85	15	15	140

Stroke	1-300	301-600	601-900	901-1050	1050-1500
EBT0050	20	30	45	50	70

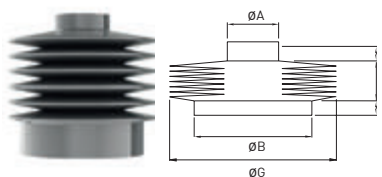

## Column Strength

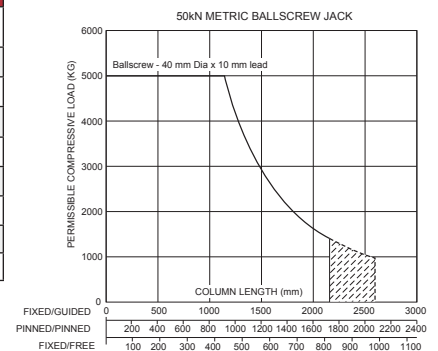

Note: For 40mm Dia x 20mm lead column strength chart refer to Engineering Guide

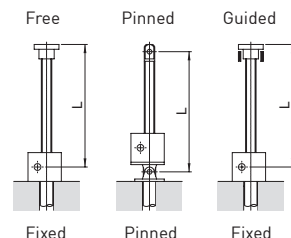

Note:

- 1 Inverted Screw Jacks - Bellows Boot Closed Height assumes screw jack mounted on a structure with thickness = 15mm
- 2 Inverted Screw Jacks - Recommended bellows boot mounting plate ØB x [E +5mm] thick.
- 3 Inverted Screw Jacks - Screw Jack mounting plate & bellows boot mounting plate are customers own supply
- 4 † Control tapes fitted (increase outer diameter by 20mm approximately).
- 5 For horizontal installations with than 450 mm of stroke, internal boot guides are recommended.
- 6 Customers with threaded end screw jacks must provide a fixing for the unattached bellows boot collar.
- 7 Bellows boots for Rotating Screw Jacks, other sizes, stroke and materials please consult Power Jacks.

Upright EBT0100-U00

Inverted EBT0100-I00

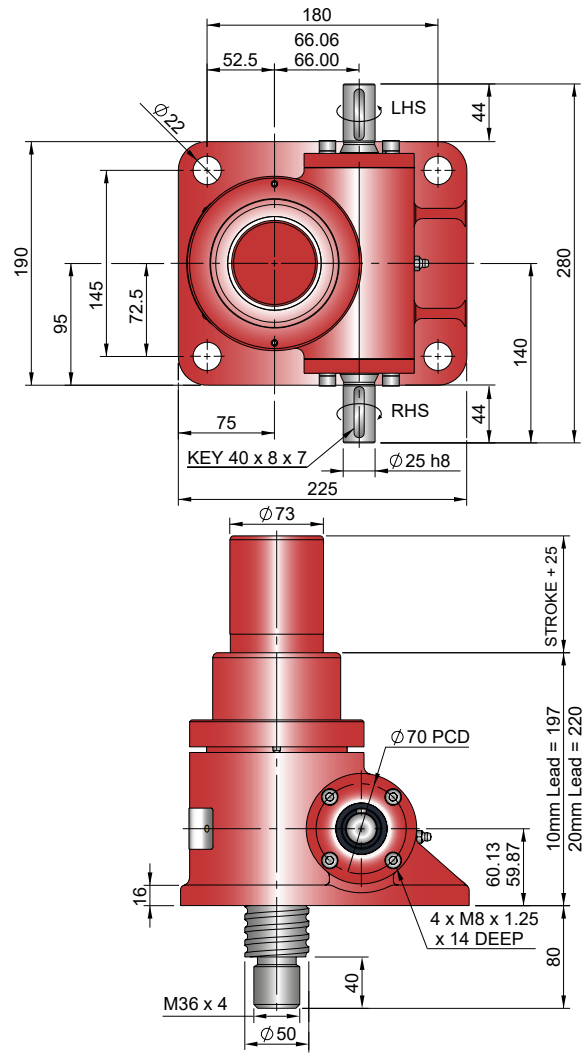
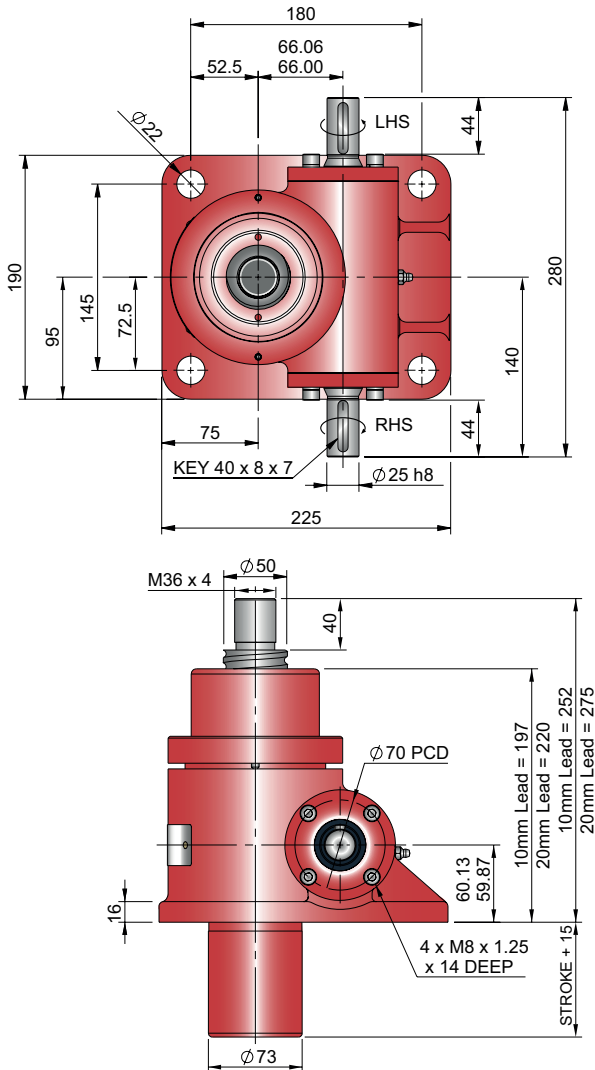

Performance

Closed Height

Model		EBT0100 EBR0100	
Capacity	kN	100	
Lifting Screw	Diameter (mm)	50	
	Lead	Option	1   2
	mm	10	20
Gear Ratio Option 1	Gear Ratio	8:1	
	Static Efficiency	0.546	0.581
	Dynamic Efficiency	0.645	0.674
Gear Ratio Option 2	Gear Ratio	24:1	
	Static Efficiency	0.348	0.370
	Dynamic Efficiency	0.450	0.470
Max. Input power (kW)	Gear Ratio Option 1	3.75	
	Gear Ratio Option 2	1.125	
Start up torque at full load (Nm)	Gear Ratio Option 1	36.4	68.5
	Gear Ratio Option 2	19.1	35.8

Model		EBT0100 EBR0100	
Capacity	kN	100	
Lifting Screw (mm)		10	20
Turn of worm for travel of lifting screw	Gear Ratio 1	6 Turn	7.5mm   15mm
	Gear Ratio 2	24 Turn	10mm   20mm
Maximum Through Torque (Nm)		347	
Lifting Screw Restraining Torque (Nm)		181	340
Worm Shaft Maximum Radial Load (N)		1000	
Maximum Input Speed (rpm)		1800	
Gear Case Material		SG Iron	
Weight (kg) - stroke = 150mm	EMT	24.3	
	EMR	28.8	
Weight (kg) - per extra 25mm stroke	EMT	0.58	
	EMR	0.36	

Note: All dimension in millimetres unless otherwise stated.  
Designs subject to change without notice

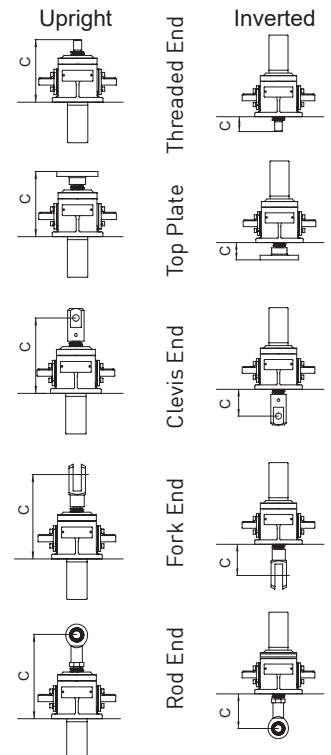



## Upright EBT0200-U00

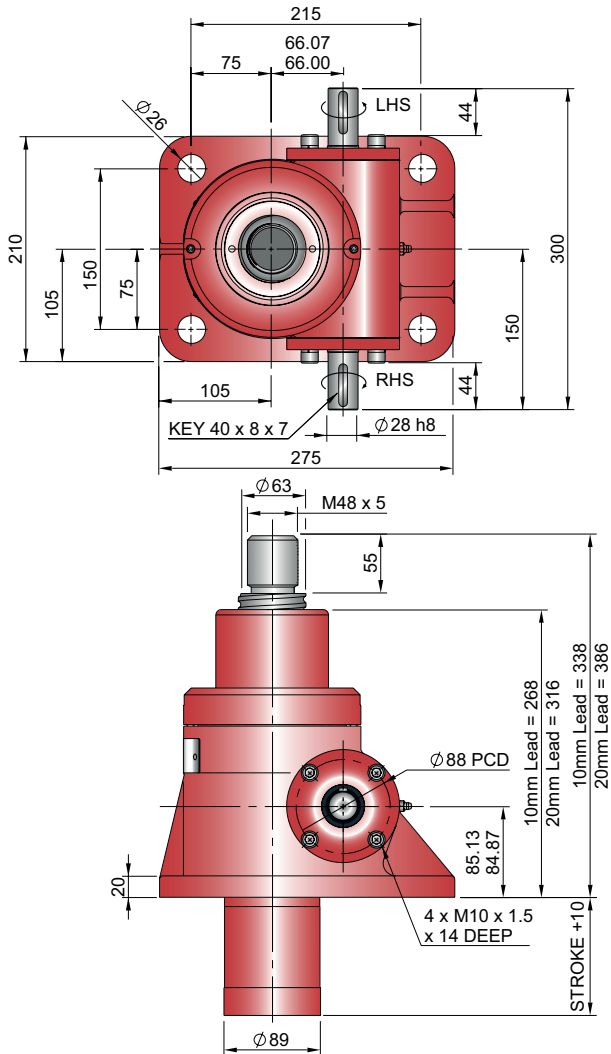

## Inverted EBT0200-I00

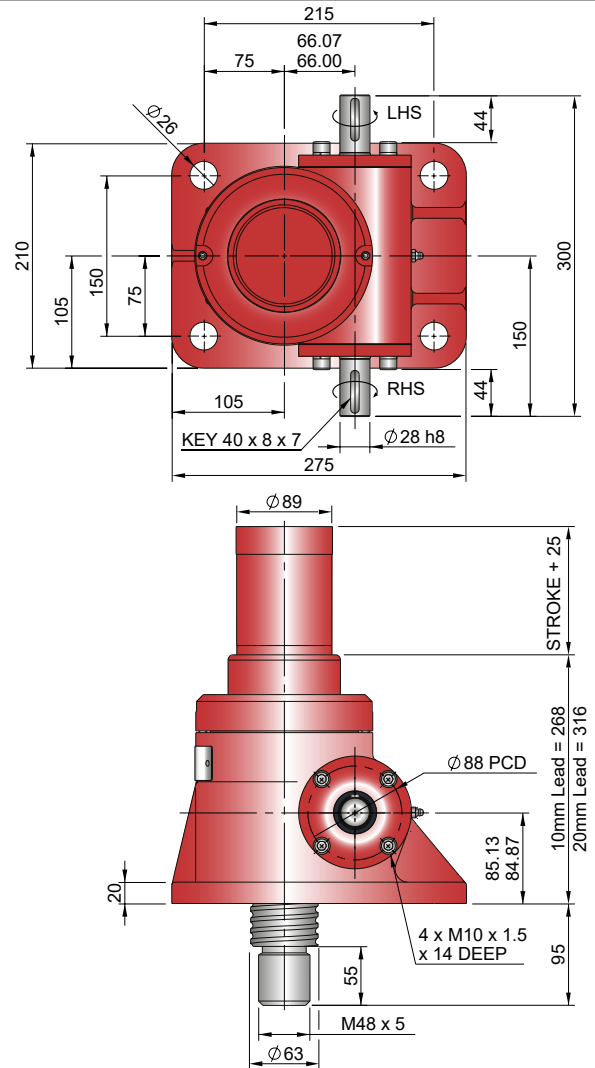

## Performance

## Closed Height

Model		EBT0200 EBR0200	
Capacity	kN	200	
Lifting Screw	Diameter (mm)	63	
	Lead	Option	1   2
		mm	10   20
Gear Ratio Option 1	Gear Ratio	8:1	
	Static Efficiency	0.529	0.571
	Dynamic Efficiency	0.631	0.665
Gear Ratio Option 2	Gear Ratio	24:1	
	Static Efficiency	0.337	0.364
	Dynamic Efficiency	0.440	0.465
Max. Input power (kW)	Gear Ratio Option 1	3.75	
	Gear Ratio Option 2	1.125	
Start up torque at full load (Nm)	Gear Ratio Option 1	75.2	139.4
	Gear Ratio Option 2	39.4	72.9

Model		EBT0200 EBR0200	
Capacity	kN	200	
Lifting Screw (mm)		10	20
Turn of worm for travel of lifting screw	Gear Ratio 1	6 Turn	7.5mm   15mm
	Gear Ratio 2	24 Turn	10mm   20mm
Maximum Through Torque (Nm)		396	
Lifting Screw Restraining Torque (Nm)		370	690
Worm Shaft Maximum Radial Load (N)		1600	
Maximum Input Speed (rpm)		1800	
Gear Case Material		Steel	
Weight (kg) - stroke = 150mm	EMT	42.4	
	EMR	49.58	
Weight (kg) - per extra 25mm stroke	EMT	0.84	
	EMR	0.52	

Note: All dimension in millimetres unless otherwise stated.  
Designs subject to change without notice

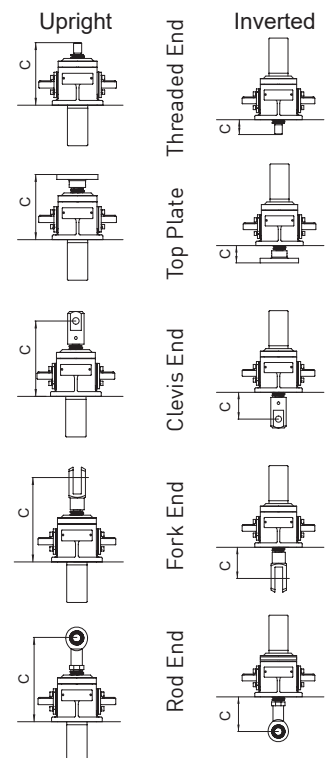



## Upright EBR0200-U00

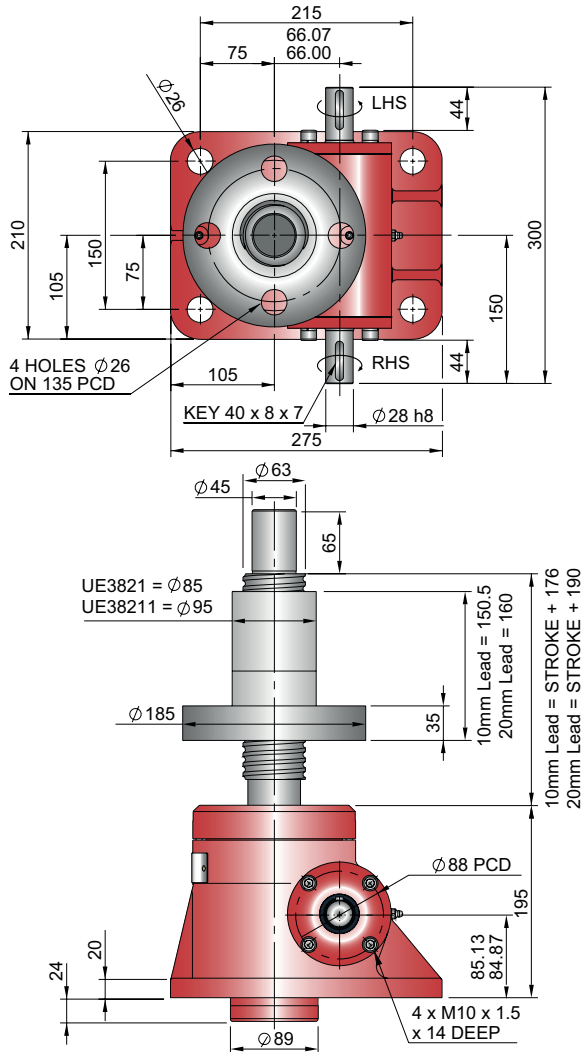

## Inverted EBR0200-I00

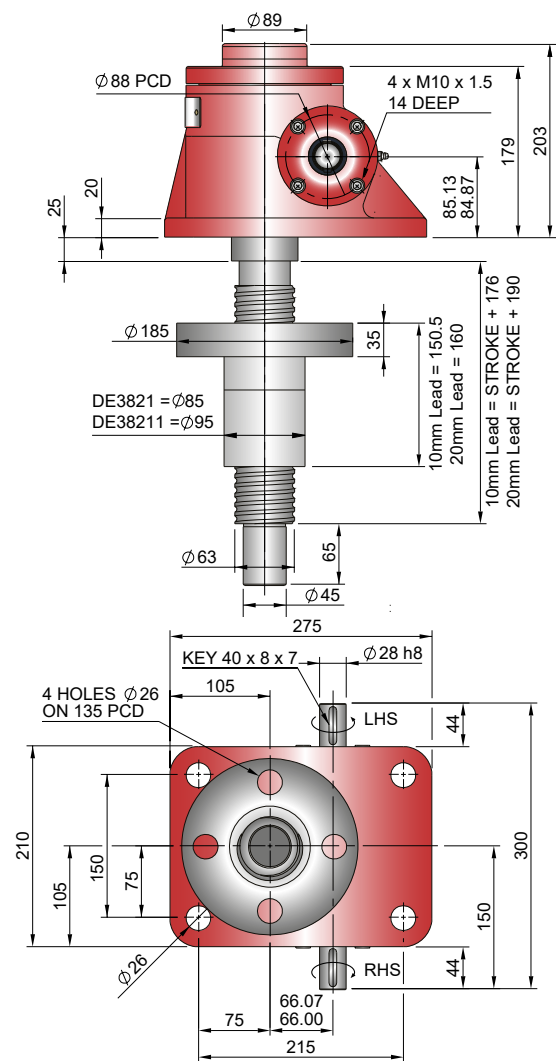

## Closed Height & Bellows Boots

## Column Strength

Closed Height "C"	Threaded End		Top Plate		Clevis End		Fork End		Rod End						
	Upright	Inverted	Upright	Inverted	Upright	Inverted	Upright	Inverted	Upright	Inverted					
EBT0200	200	80	200	80	245	125	302	182	283	163					
Stroke (mm)	EBT0200 with Bellows Boots														
Lead (mm)	10	20	10 & 20	10	20	10 & 20	10	20	10 & 20	10	20	10 & 20			
1-300	348	396	140	348	396	140	393	441	185	483	531	275	470	518	262
301-600	358	406	150	358	406	150	403	451	195	493	541	285	480	528	272
601-1050	378	426	170	378	426	170	423	471	215	513	561	305	500	548	292
1051-1500	398	446	190	398	446	190	443	491	235	533	581	325	520	568	312

Model	A	B	D	E	G
EBT0200	75	105	20	20	165

Stroke	1-300	301-600	601-1050	1051-1500
EBT0200	20	30	50	70

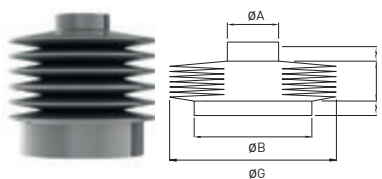

Note:

- 1 Inverted Screw Jacks - Bellows Boot Closed Height assumes screw jack mounted on a structure with thickness = 20mm
- 2 Inverted Screw Jacks - Recommended bellows boot mounting plate ØB x (E +5mm) thick.
- 3 Inverted Screw Jacks - Screw Jack mounting plate & bellows boot mounting plate are customers own supply
- 4 † Control tapes fitted (increase outer diameter by 20mm approximately).
- 5 For horizontal installations with than 450 mm of stroke, internal boot guides are recommended.
- 6 Customers with threaded end screw jacks must provide a fixing for the unattached bellows boot collar.
- 7 Bellows boots for Rotating Screw Jacks, other sizes, stroke and materials please consult Power Jacks.

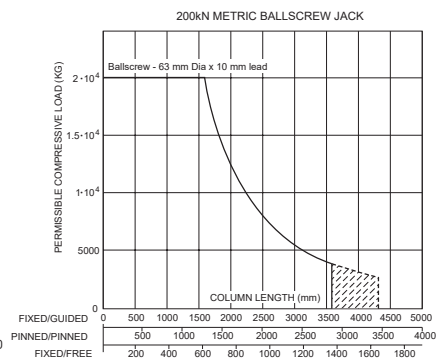

Note: For 63mm Dia x 20mm lead column strength chart refer to Engineering Guide

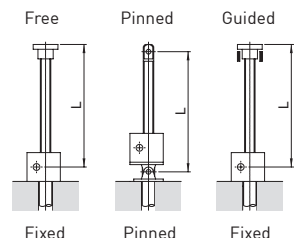

## Upright EBT0300-U00

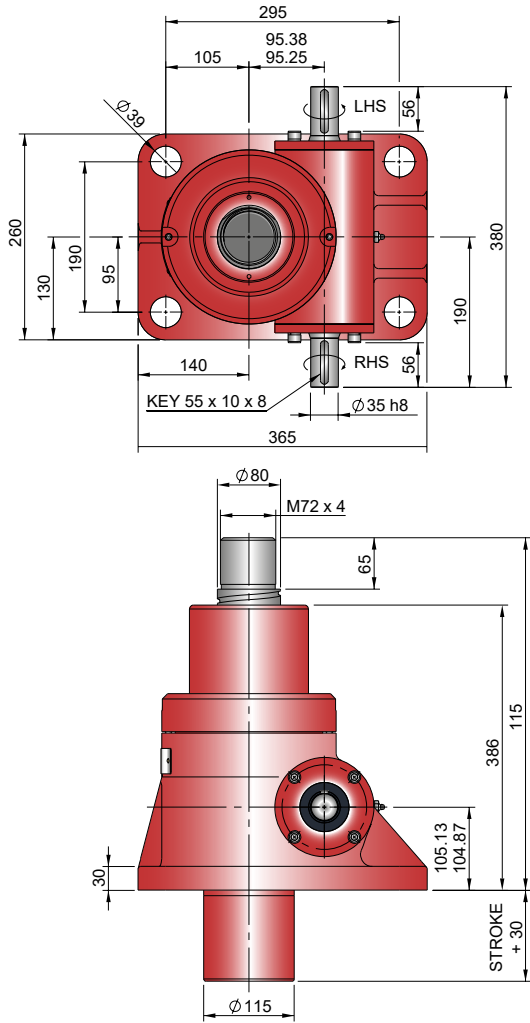

## Inverted EBT0300-I00

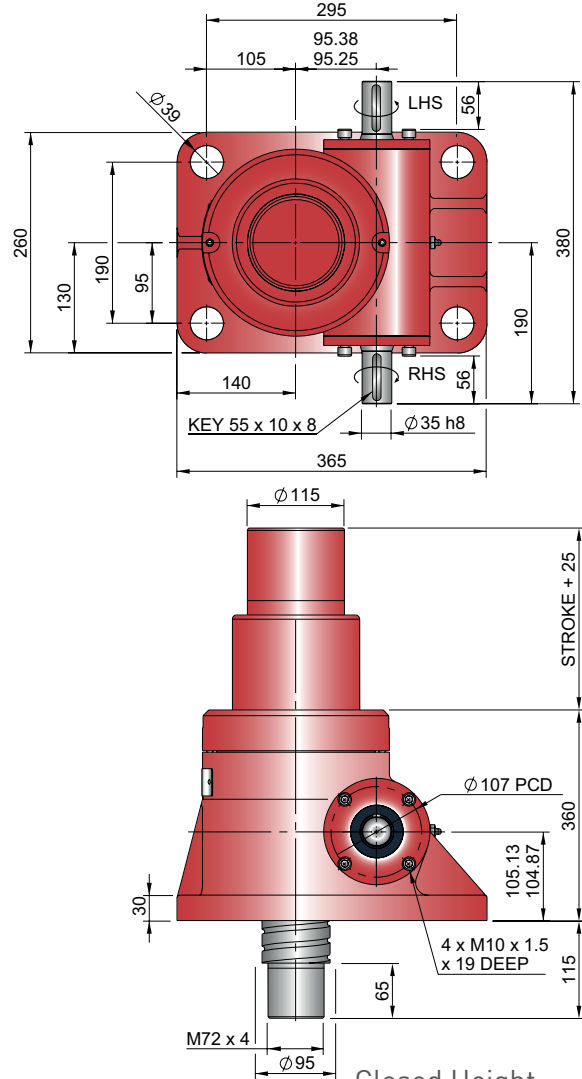

## Performance

## Closed Height

Model		EBT0300 EBR0300
Capacity	kN	300
Lifting Screw	Diameter (mm)	80
	Lead	Option 1: 1 mm: 20
Gear Ratio Option 1	Gear Ratio	10 2/3:1
	Static Efficiency	0.492
	Dynamic Efficiency	0.595
Gear Ratio Option 2	Gear Ratio	32:1
	Static Efficiency	0.278
	Dynamic Efficiency	0.371
Max. Input power (kW)	Gear Ratio Option 1	6.0
	Gear Ratio Option 2	1.9
Start up torque at full load (Nm)	Gear Ratio Option 1	182
	Gear Ratio Option 2	107.3

Model		EMT0300 EMR0300
Capacity	kN	300
Lifting Screw (mm)		20
Turn of worm for travel of lifting screw	Gear Ratio 1	6 Turn
	Gear Ratio 2	24 Turn
Maximum Through Torque (Nm)		1440
Lifting Screw Restraining Torque (Nm)		1030
Worm Shaft Maximum Radial Load (N)		2170
Maximum Input Speed (rpm)		1800
Gear Case Material		Steel
Weight (kg) - stroke = 150mm	EMT	92.4
	EMR	113.78
Weight (kg) - per extra 25mm stroke	EMT	1.55
	EMR	1.13

Note: All dimension in millimetres unless otherwise stated.  
Designs subject to change without notice

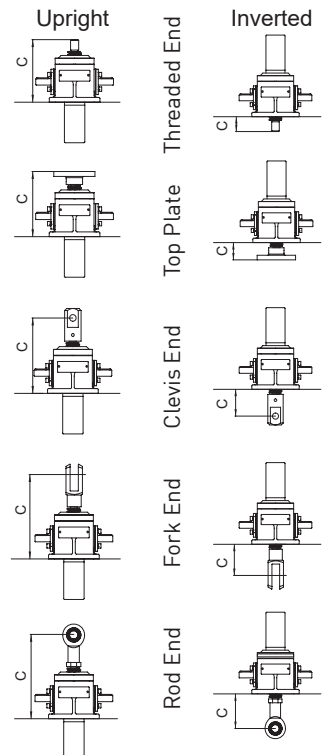

## Upright EBR0300-U00

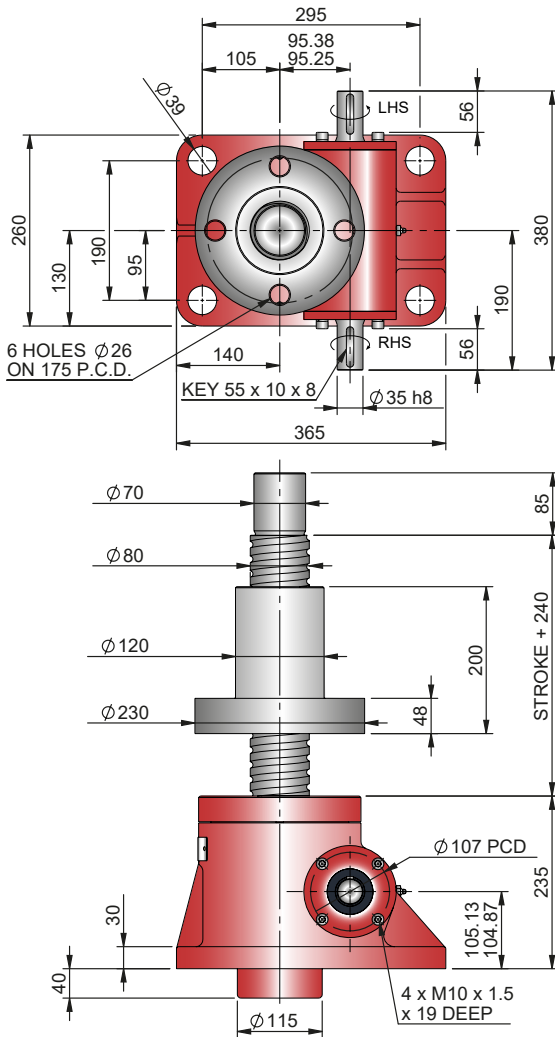

## Inverted EBR0300-I00

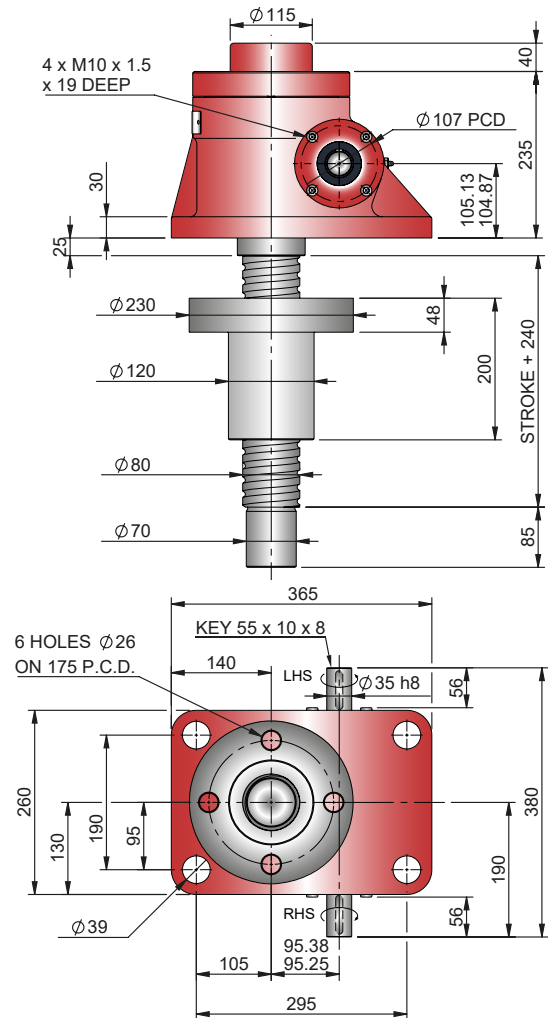

## Closed Height & Bellows Boots

Closed Height "C"	Threaded End		Top Plate		Clevis End		Fork End		Rod End	
	Upright	Inverted	Upright	Inverted	Upright	Inverted	Upright	Inverted	Upright	Inverted
EBT0300	325	115	325	115	365	155	148	98	150	70
Stroke (mm)	EBT0300 with Bellows Boots									
1-300	470	135	470	135	510	175	-	-	-	-
301-600	480	145	480	145	520	185	-	-	-	-
601-1050	500	165	500	165	540	205	-	-	-	-
1051-1500	520	185	520	185	560	225	-	-	-	-

Model	A	B	D	E	G
EBT0300	110	150	20	20	180

Stroke	1-300	301-600	601-1050	1050-1500
EBT0300	20	30	50	70

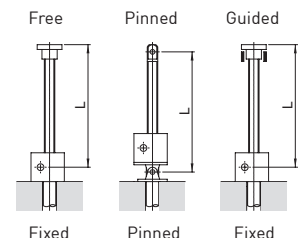
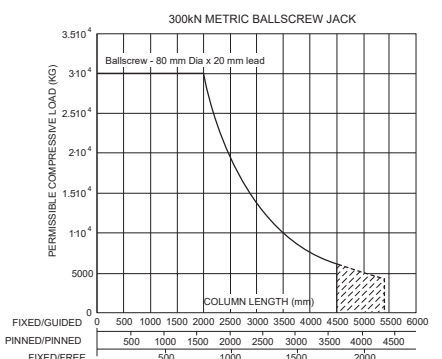
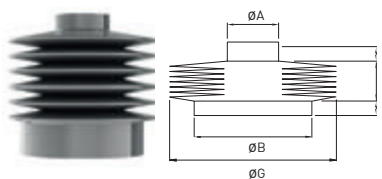

Note:

- 1 Inverted Screw Jacks - Bellows Boot Closed Height assumes screw jack mounted on a structure with thickness = 30mm
- 2 Inverted Screw Jacks - Recommended bellows boot mounting plate  $\varnothing B \times [E + 5\text{mm}]$  thick.
- 3 Inverted Screw Jacks - Screw Jack mounting plate & bellows boot mounting plate are customers own supply
- 4 † Control tapes fitted (increase outer diameter by 20mm approximately).
- 5 For horizontal installations with than 450 mm of stroke, internal boot guides are recommended.
- 6 Customers with threaded end screw jacks must provide a fixing for the unattached bellows boot collar.
- 7 Bellows boots for Rotating Screw Jacks, other sizes, stroke and materials please consult Power Jacks.

E-Series

5

## E-Series Ball Screw Jack

PERFORMANCE  
ENHANCED VARIANTS  
TO SOLVE SPECIFIC  
APPLICATION  
REQUIREMENTS

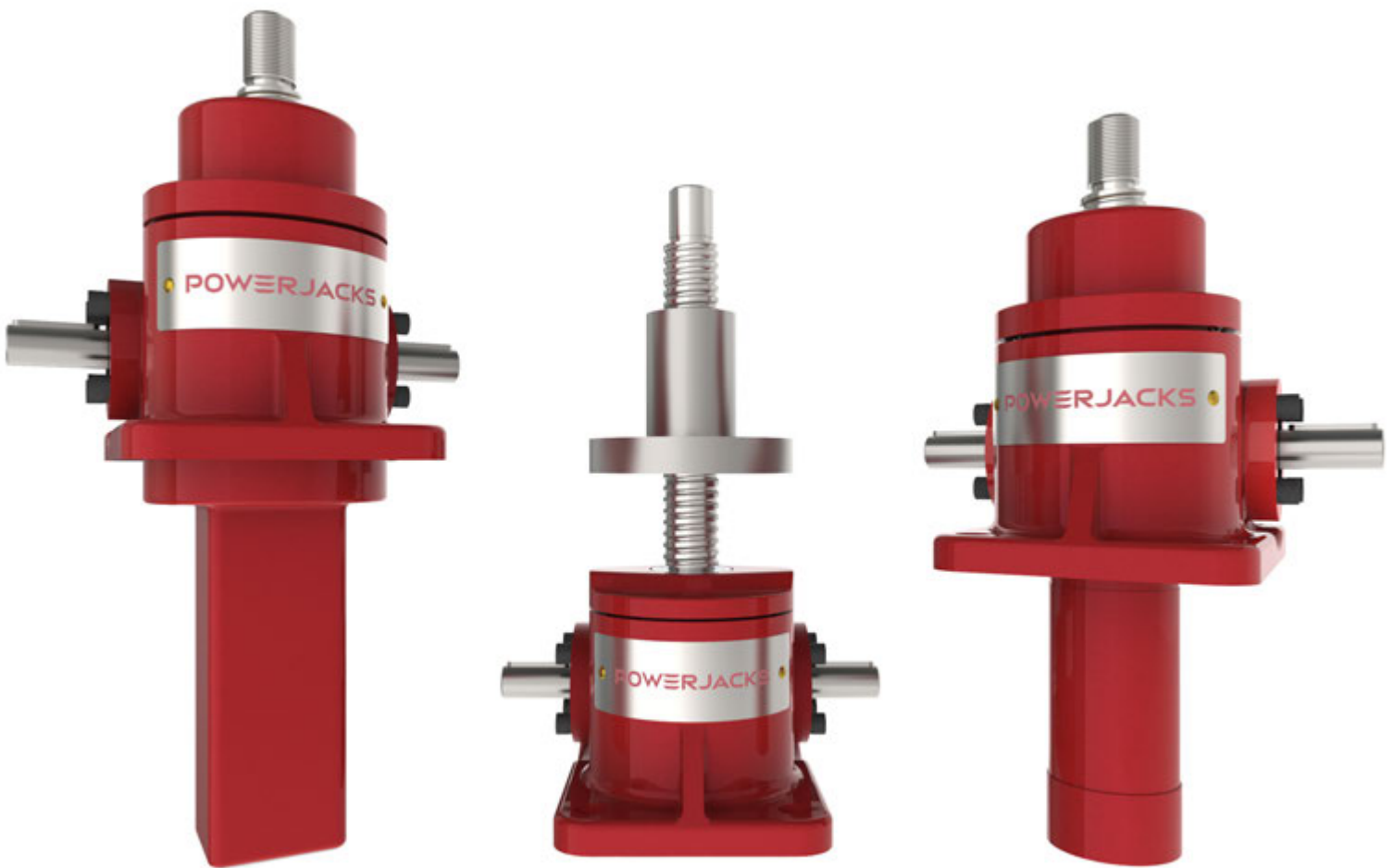

### Double Clevis

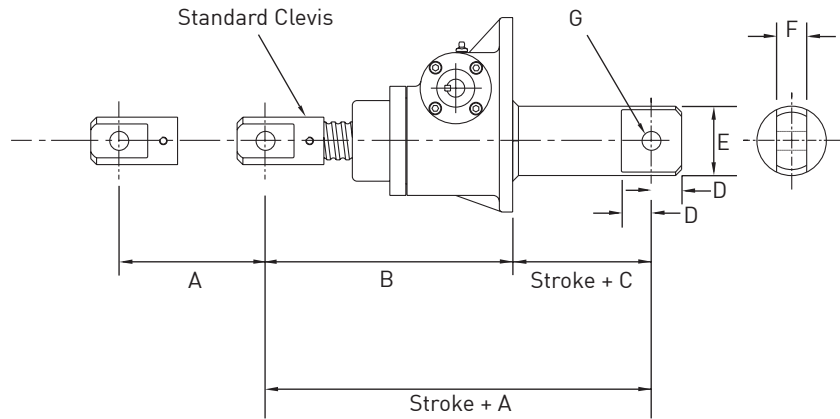

Model	EBT0010	EBT0025		EBT0050		EBT0100		EBT0200		EBT0300	EBT0500
Capacity	10	25	25	50	50	100	100	200	200	300	500
Lead Option	1	1	2	1	2	1	2	1	2	1	1
A	Available on Request	260	287	313	364	427	450	525	573	Available on Request	Available on Request
B		202	229	245	296	299	322	386	434		
C		58	58	68	68	128	128	139	139		
D		23	23	30	30	33	33	40	40		
E		48.3	48.3	60.3	60.3	73	73	102	102		
F		30	30	35	35	40	40	50	50		
G		16	16	20	20	22	22	30	30		
Max Raise at Max Rated Load in Compression		280	200	600	560	658	588	769	621		

**Note**

1. For other performance and dimension information refer to translating screw models.
2. All dimensions in millimetres unless otherwise stated.

### Reduced Backlash Ball Screw Jacks



Metric Ball Screw Jacks can be provided with preloaded ball nuts to give reduced axial backlash as a high efficiency alternative to the metric machine screw anti-backlash option. Preloading on the ball nut is obtained by the "Interference Ball" method. By fitting Interference balls in the ball nut to obtain a diametrical interference fit and using the original track form, a four-point contact results.

The anti-rotation device is available for translating ball screw models only. It is used only when the load to be moved (actuated) may rotate, i.e. the screw is unguided and does not prevent rotation.

The anti-rotation device consists of a square steel tube which guides the movement of a square aluminium bronze guide block fitted to the end of the ball screw. The guide block also acts as a stop nut.

Model	EBT0010	EBT0025	EBT0050	EBT0100	EBT0200	EBT0300	EBT0500
Capacity (kN)	10	25	50	100	200	300	500
A	AOR	50	70	AOR	AOR	AOR	AOR
B	AOR	50	60	AOR	AOR	AOR	AOR
C	AOR	90	115	AOR	AOR	AOR	AOR
D	AOR	16	20	AOR	AOR	AOR	AOR

**Note**

1. AOR = Application On Request, consult Power Jacks Ltd.
2. All dimensions in millimetres unless otherwise stated.

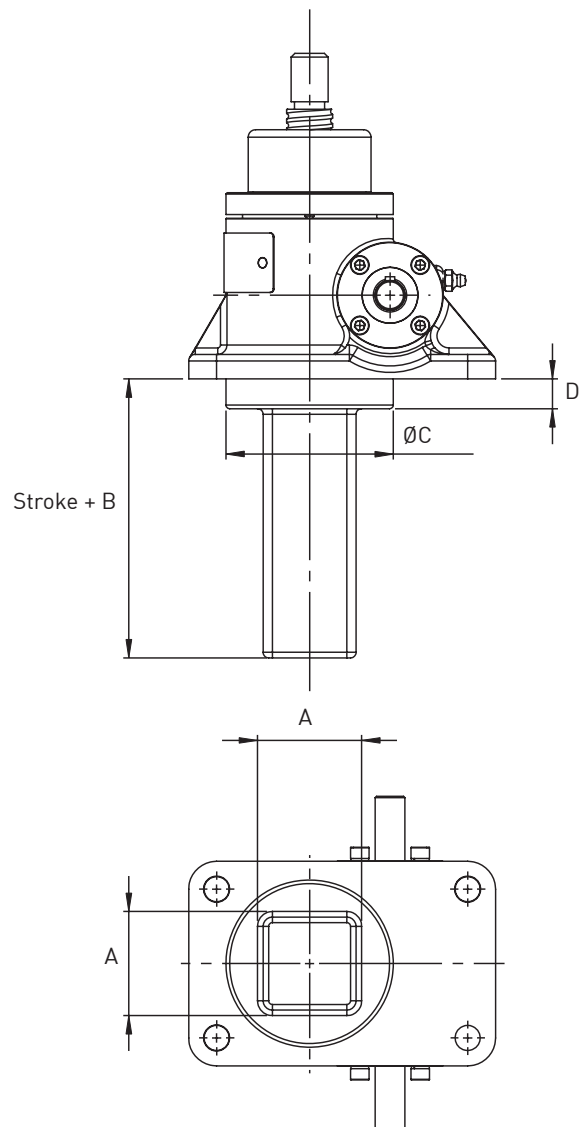



## E-Series Roller Screw Jack

HIGH PRECISION  
PLANETARY ROLLER SCREW  
INTEGRATED WITH OUR  
FLEXIBLE E-SERIES DESIGN  
FOR A SCREW JACK THAT  
MEETS THE NEEDS OF  
HIGH DUTY & HIGH LOAD  
APPLICATIONS.

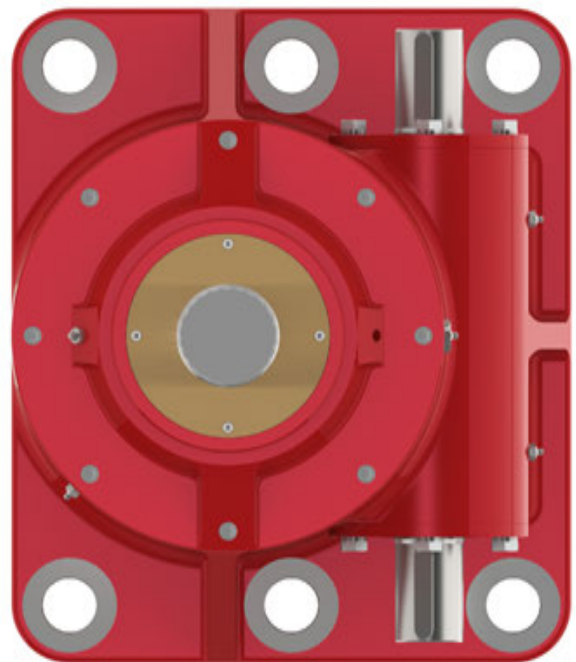

### Features

- High Performance Power Jack
- Metric Single Face Roller Screw Jacks
- Capacities - up to 1000kN as standard
- High precision planetary roller screw
- Translating and Rotating Screw in Upright and Inverted types
- Precision Worm Gear Set
- 2 Gear ratios and 2 screw leads as standard
- Anti-Rotation Option
- 6 mounting options including trunnion and double clevis
- Special custom designs available



An extensive range of axially translating and rotating screw jacks fitted with the patented Spiracon roller screw and designed specifically to customers' application requirements. The Spiracon roller screw is an extremely high performance screw mechanism exhibiting almost no axial backlash and is designed to meet the following demands:

- High precision and repeatable positioning
- High speed
- High dynamic load capacity
- High duty
- High efficiency
- Long life
- Minimum maintenance requirements

The range covers lifting capacities up to 1000kN, with many design features available to meet the customers' particular requirements. The units' gearbox is based on the standard range of Power Jacks screw jacks, although other gearbox types can be designed for specific applications. The gearboxes are either grease or oil lubricated depending on the application. The roller screw is based around the standard Spiracon planetary roller screw range, with alternative nut housings available to meet the requirements of specific applications.

## Principle of Operation

The Spiracon™ system consists of a multi-start screw with an involute thread form and a number of planetary rollers with annular grooves, which engage with the screw. These rollers also engage with a grooved load bearing element, which transmits the load through roller thrust bearings, to the nut housing. The rolling action results in a high efficiency mechanism, while the line contact and hardened and ground construction achieves a high dynamic load carrying capacity, together with almost no axial backlash or wear.

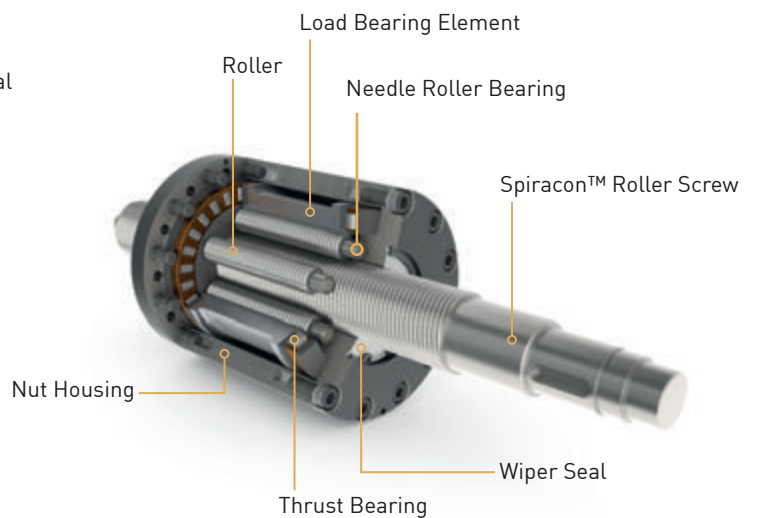
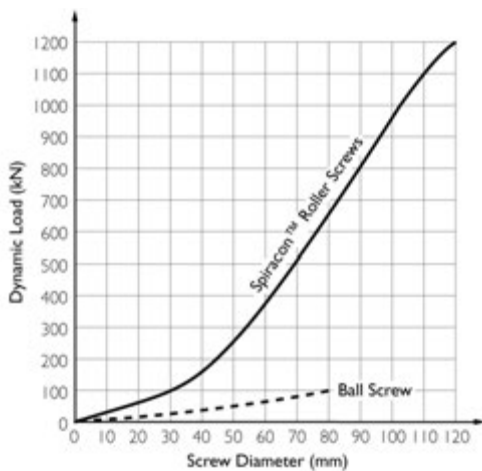

## Typical Applications

Roller Screw Jacks are generally used when the application is moving a high load with a high duty cycle. Size for size roller screws offer higher load carrying capabilities than ball screws so for high load applications allow for more compact working envelopes. The high efficiency of the roller screw & nut significantly increase the efficiency of a screw jack in comparison to a Machine Screw Jack. Due to their high efficiency they nearly always require a brake to hold position. They are used in a wide variety of applications including Automotive, Steel, Defence and Nuclear.

## Standard Designs

The standard E-Series roller screw jack is available in translating and rotating screw designs in capacity sizes up to 1000kN.

The design is optimised for high load and high performance in a compact form. There is a large selection of options and accessories (section-7) available so you can configure a standard design that is just right for your application.

These options include Low-Backlash and Anti-Rotation designs.

## Special Designs

We can fully customise our screw jacks so that your application can be the best.

Customisation can be anything from a small modification such as an extra bolt hole on an end fitting to a completely new design of screw jack based on our class leading technology.

For more details please see the Special Screw Jack information in Section-8 or contact us today with your requirements. Our team are looking forward to working with you.

## Selecting the Right Screw Jack

Consider all application constraints then choose a product that looks suitable for the intended application. Calculate the power and torque requirements. This is a 5 step process:

- Screw Jack Input Speed (RPM)
- Operating Input Power (kW)
- Operating Input Torque (Nm)
- Screw Jack Start-up Torque (Nm)
- Mechanical Power and Torque Check

## Systems

The screw jacks can be connected together in systems so that multiple units can be operated and controlled together. These jacking system arrangements or configurations can be built in many formats with the use of bevel gearboxes, motors, reduction gearbox, drive shafts, couplings, plummer blocks and motion control devices.

The use of bevel gearboxes allows the distribution of drive throughout a jacking system. The gearboxes come in 2, 3 and 4 way drive types. See the Bevel Gearboxes Section-10 for more details.

Bevel gearboxes and other system components can also be supplied in stainless steel or other corrosion resistant designs.

Two of the most popular system configurations are the 'H' and 'U' configured jacking systems. Remember that multiple screw jacks can be linked together mechanically or electrically. The latter is useful if there is no space for linking drive shafts.

If multiple roller screw jacks are connected in a mechanically linked system then the complete system in some circumstances may be considered self-locking depending on the gear ratios and efficiencies of units in the system. In general, Power Jacks recommend a brake is used on **ALL** Roller Screw Jack systems. If you would like this checked, consult Power Jacks. Alternatively, to be sure, include a brake on the system either as a stand alone device or as a brake motor.



E-Series

7

## E-Series Screw Jack

ACCESSORIES FOR ALL  
MACHINE SCREW,  
STAINLESS STEEL,  
BALL SCREW AND  
ROLLER SCREW JACKS



## Top Plate

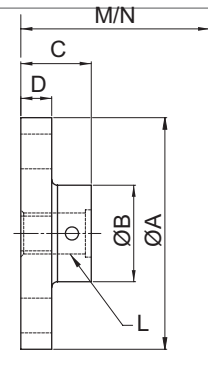
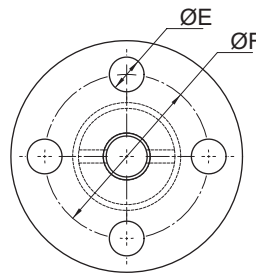

Base of Screw Jack

## Clevis End

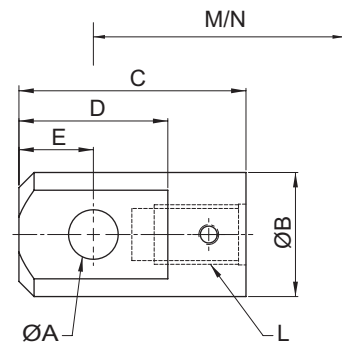
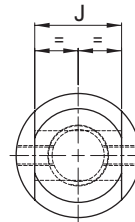
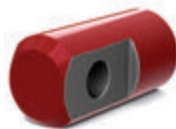

Base of Screw Jack

## Fork End

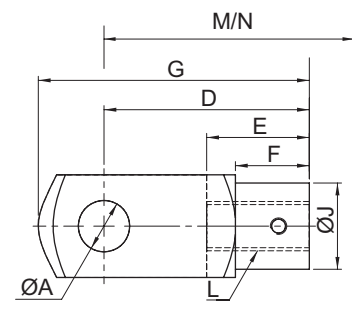
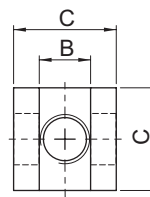

Base of Screw Jack

## Rod End

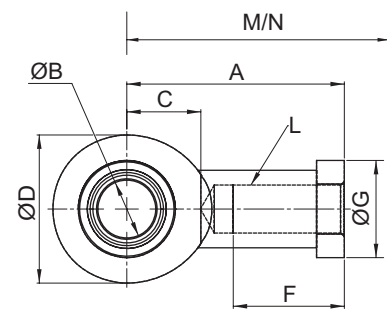
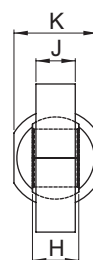

Base of Screw Jack



Capacity (kN)		5	10	25	50	100	200	300	500	1000	1500	2000	
Top Plate	ØA	65	80	100	120	150	170	240	280	380	400	470	
	ØB	25	30	40	50	65	75	110	150	200	215	265	
	C	21	25	31.5	36.5	42	58	67	92	127	162	172	
	D	8	10	12	16	20	25	30	35	75	80	100	
	ØE x QTY	9 x 4	11 x 4	13.5 x 4	18 x 4	22 x 4	26 x 4	33 x 4	33 x 4	51 x 4	51 x 6	52 x 8	
	ØF (PCD)	45	55	70	85	110	120	170	215	290	310	370	
	L	M10 x 1.5	M12 x 1.75	M20 x 2.5	M24 x 3	M36 x 4	M48 x 5	M72 x 4	M100 x 4	M125 x 4	M145 x 6	M180 x 8	
	M#1	Upright	95	125	145	185	200	265	325	390	560	620	690
		Inverted	40	45	55	65	80	95	115	150	260	230	280
	N#2	Upright	-	150	175	218	252	338	445	-	-	-	-
Inverted		-	45	55	65	80	95	115	-	-	-	-	

Capacity (kN)		5	10	25	50	100	200	300	500	1000	1500	2000	
Clevis Plate	ØA	10	12	16	20	22	30	45	60	90	105	125	
	ØB	25	30	40	50	65	75	110	150	200	230	270	
	C	56	63	79.5	91.5	120	143	167	217	297	404	490	
	D	30	36	46	60	66	80	120	150	210	215	270	
	E	15	18	23	30	33	40	60	75	105	105	130	
	J	15	20	30	35	40	50	80	110	140	150	175	
	L	M10 x 1.5	M12 x 1.75	M20 x 2.5	M24 x 3	M36 x 4	M48 x 5	M72 x 4	M100 x 4	M125 x 4	M145 x 6	M180 x 8	
	M#1	Upright	115	145	170	210	245	310	365	440	625	760	880
		Inverted	60	65	80	90	125	140	155	200	325	370	470
	N#2	Upright	-	170	200	243	297	383	485	-	-	-	-
Inverted		-	65	80	90	125	140	155	-	-	-	-	

Capacity (kN)		5	10	25	50	100	200	300	500	1000	1500	2000
Fork End	ØA	10	12	20	25	35	50	Available on Request	Available on Request	Available on Request	Available on Request	Available on Request
	B	10	12	20	25	35	50					
	C	20	24	40	50	70	96					
	D	40	48	80	100	144	192					
	E	20	24	40	50	72	96					
	F	15	18	30	36	54	73					
	G	52	62	105	132	188	265					
	ØJ	18	20	34	42	60	82					
	L	M10 x 1.5	M12 x 1.75	M20 x 2.5	M24 x 3	M36 x 4	M48 x 5					
	M#1	Upright	114	148	194	248	302					
Inverted		59	68	104	128	182	230					
N#2	Upright	-	173	224	281	354	473					
	Inverted	-	68	104	128	182	230					

Capacity (kN)		5	10	25	50	100	200	300	500	1000	1500	2000
Rod End	A	43	50	77	94	125	160	Available on Request	Available on Request	Available on Request	Available on Request	Available on Request
	ØB	10	12	20	25	35	50					
	C	15	18	27	32	42	60					
	ØD	29	34	53	64	82	112					
	F	-	23	40	48	60	68					
	ØG	19	22	35	42	58	75					
	H	9	10	16	20	25	35					
	J	7	8	13	17	21	30					
	K	17	19	32	36	50	65					
	L	M10 x 1.5	M12 x 1.75	M20 x 1.5	M24 x 2	M36 x 3	M45 x 3					
M#1	Upright	117	150	190	242	283	367					
	Inverted	62	70	100	122	163	197					
N#2	Upright	-	175	220	275	335	440					
	Inverted	-	70	100	122	163	197					

Note

1. M = For Machine Screw Jacks
2. N = For Ball Screw Jacks, Standard Lead only.

### Features

- Protects the screw from dust and dirt
- Guards against moisture and corrosive contaminants
- Helps maintain the proper lubrication
- Boots are made of P.V.C. coated nylon with sewn construction. Other materials are available for applications involving high temperatures, highly corrosive atmospheres and other special conditions.



### Boot Dimensions

Model	A	B	C	D	E
EMT0005	25	60	100	13	13
EMT0010	30	70	110	15	15
EMT0025	40	90	120	15	23
EMT0050	50	115	140	15	31
EMT0100	65	136	150	15	31
EMT0200	75	165	165	20	20
EMT0300	110	220	191	20	20
EMT0500	150	285	210	20	45
EMT1000	200	220	244	20	20
EMT1500	215	410	480	25	25
EMT2000	265	396	470	25	25

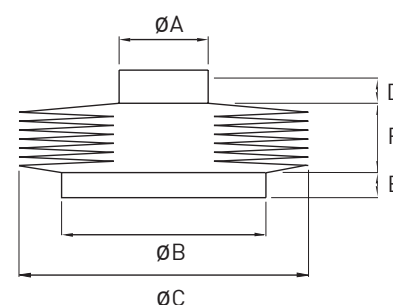

Model		EMT0005	EMT0010	EMT0025	EMT0050	EMT0100	EMT0200	EMT0300	EMT0500	EMT1000	EMT1500	EMT2000	
F	Stroke 0 → 150	10	8	8	8	-	-	-	-	-	-	-	
	Stroke 0 → 300	20	20	20	20	20	20	20	20	20	-	-	
	Stroke 0 → 500	-	-	-	-	-	-	-	-	-	20	25	
	Stroke 301 → 600	30	35	30	30	30	30	30	30	30	-	-	
	Stroke 501 → 1000	-	-	-	-	-	-	-	-	-	45	40	
	Stroke 601 → 1050	-	-	50	50	50	50	50	50	50	50	-	-
	Stroke 1051 → 1500	-	-	70	70	70	70	70	70	70	70	-	-
	Stroke 1001 → 2000	-	-	-	-	-	-	-	-	-	-	80	75†
Stroke 2001 → 4000	-	-	-	-	-	-	-	-	-	-	160	145†	

F = Bellows boot minimum closed thickness, - = Not applicable

### Closed Heights

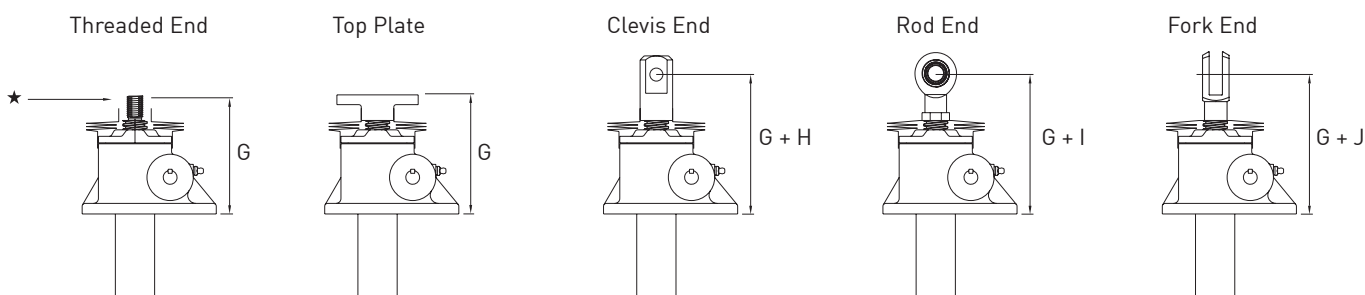

#### Notes for all metric machine screw jacks with bellows boots

1. Supplied complete with a set of corrosion-resistant 'jubilee' clips (2) suitable for fitting over collar diameters.
2. † Control tapes are fitted (approximately 20 mm increase to outer diameter).
3. For horizontal installation exceeding 450 mm of travel, internal boot guides are recommended.
4. Customers with threaded end screw jacks must provide a fixing for the unattached collar (★).
5. Bellows boots for Rotating Screw Jacks consult Power Jacks Ltd.
6. For other sizes, strokes and materials please consult Power Jacks Ltd.
7. All dimensions in millimetres unless otherwise stated.
8. Dimensions subject to change without notice.
9. Screw Jack mounting plate and bellows boot mounting plate are usually all part of the customers superstructure (★ ★).  
For other options consult Power Jacks.

Closed Height for all Upright Machine Screw Jacks and Anti-Rotation (Keyed) Types

Model	EMT0005	EMT0010	EMT0025	EMT0050	EMT0100	EMT0200	EMT0300	EMT0500	EMT1000	EMT1500	EMT2000
G	Stroke 0 → 150	95	125	145	185	-	-	-	-	-	-
	Stroke 0 → 300	120	130	145	185	200	265	325	390	560	-
	Stroke 0 → 500	-	-	-	-	-	-	-	-	-	620
	Stroke 301 → 600	120	140	170	210	200	265	325	415	560	-
	Stroke 501 → 1000	-	-	-	-	-	-	-	-	-	630
	Stroke 601 → 1050	-	-	195	210	225	290	350	440	585	-
	Stroke 1051 → 1500	-	-	195	235	250	315	375	465	610	-
	Stroke 1001 → 2000	-	-	-	-	-	-	-	-	-	665
Stroke 2001 → 4000	-	-	-	-	-	-	-	-	-	745	
H	Extra Closed Height for Clevis	20	20	25	25	45	45	40	50	65	140
I	Extra Closed Height for Fork	19	23	49	63	102	135	Request	Request	Request	Request
J	Extra Closed Height for Rod End	37	40	60	72	98	122	Request	Request	Request	Request

Closed Height for all Upright Machine Screw Jacks with Anti-Backlash

Model	EMT0005	EMT0010	EMT0025	EMT0050	EMT0100	EMT0200	EMT0300	EMT0500	EMT1000	EMT1500	EMT2000
G	Stroke 0 → 150	95	125	145	185	-	-	-	-	-	-
	Stroke 0 → 300	120	130	145	185	200	265	340	415	585	-
	Stroke 0 → 500	-	-	-	-	-	-	-	-	-	Request
	Stroke 301 → 600	120	140	170	210	200	265	340	440	585	-
	Stroke 501 → 1000	-	-	-	-	-	-	-	-	-	Request
	Stroke 601 → 1050	-	-	195	210	225	290	340	465	610	-
	Stroke 1051 → 1500	-	-	195	235	250	315	365	490	635	-
	Stroke 1001 → 2000	-	-	-	-	-	-	-	-	-	Request
Stroke 2001 → 4000	-	-	-	-	-	-	-	-	-	Request	
H	Extra Closed Height for Clevis	20	20	25	25	45	45	40	50	65	Request
I	Extra Closed Height for Fork	19	23	49	63	102	135	Request	Request	Request	Request
J	Extra Closed Height for Rod End	37	40	60	72	98	122	Request	Request	Request	Request

Closed Height for all Upright Machine Screw Jacks with Anti-Backlash & Anti-Rotation (Keyed)

Model	EMT0005	EMT0010	EMT0025	EMT0050	EMT0100	EMT0200	EMT0300	EMT0500	EMT1000	EMT1500	EMT2000
G	Stroke 0 → 150	95	125	145	185	-	-	-	-	-	-
	Stroke 0 → 300	120	130	145	185	200	265	340	415	585	-
	Stroke 0 → 500	-	-	-	-	-	-	-	-	-	Request
	Stroke 301 → 600	120	140	170	195	200	265	340	440	585	-
	Stroke 501 → 1000	-	-	-	-	-	-	-	-	-	Request
	Stroke 601 → 1050	-	-	195	195	225	290	365	465	610	-
	Stroke 1051 → 1500	-	-	195	220	250	315	390	490	635	-
	Stroke 1001 → 2000	-	-	-	-	-	-	-	-	-	Request
Stroke 2001 → 4000	-	-	-	-	-	-	-	-	-	Request	
H	Extra Closed Height for Clevis	20	20	25	25	45	45	40	50	65	Request
I	Extra Closed Height for Fork	19	23	49	63	102	135	Request	Request	Request	Request
J	Extra Closed Height for Rod End	37	40	60	72	98	122	Request	Request	Request	Request

## Closed Heights

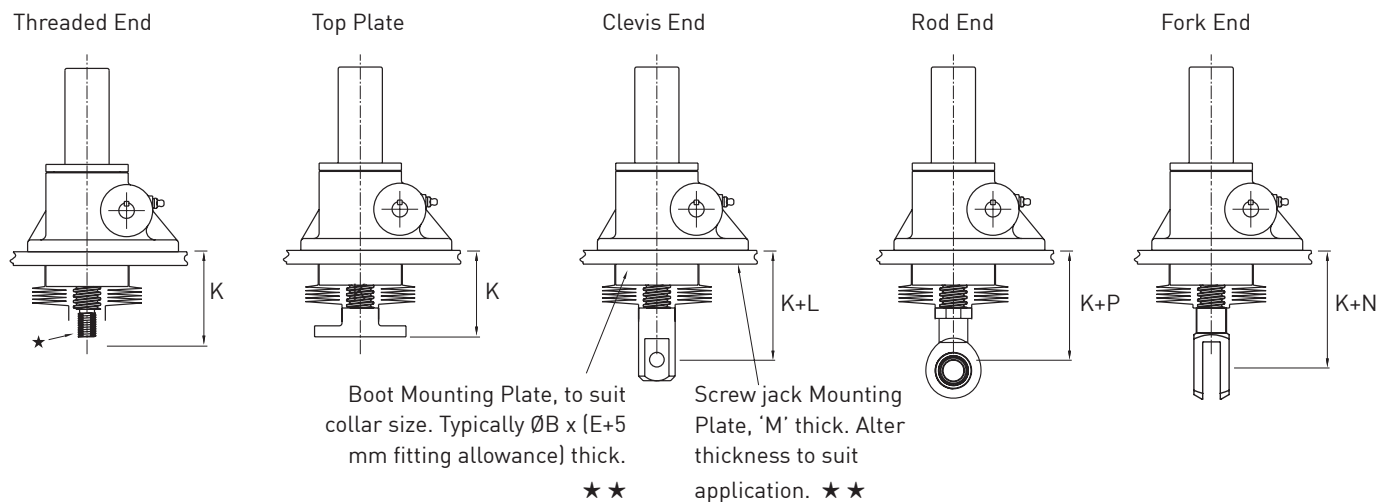

## Closed Height for all Inverted Machine Screw Jacks Standard or Anti-Backlash or Anti-Rotation (Keyed)

Model		EMT0005	EMT0010	EMT0025	EMT0050	EMT0100	EMT0200	EMT0300	EMT0500	EMT1000	EMT1500	EMT2000
M	Mounting Plate	10	10	15	15	20	20	30	30	50	60	70
K	Stroke 0 → 150	70	75	80	110	-	-	-	-	-	-	-
	Stroke 0 → 300	90	95	80	120	105	120	140	175	260	-	-
	Stroke 301 → 500	-	-	-	-	-	-	-	-	-	230	280
	Stroke 301 → 500	90	95	105	130	130	145	165	200	260	-	-
	Stroke 501 → 1000	-	-	-	-	-	-	-	-	-	225	280
	Stroke 601 → 1050	-	-	130	150	130	145	165	225	285	-	-
	Stroke 1051 → 1500	-	-	130	170	155	170	190	250	310	-	-
	Stroke 1001 → 2000	-	-	-	-	-	-	-	-	-	290	285+
Stroke 2001 → 4000	-	-	-	-	-	-	-	-	-	370	350+	
L	Extra Closed Height for Clevis	20	20	25	25	45	45	40	50	65	140	190
N	Extra Closed Height for Fork	19	23	49	63	102	135	Request	Request	Request	Request	Request
P	Extra Closed Height for Rod End	37	40	60	72	98	122	Request	Request	Request	Request	Request

## Closed Height for all Inverted Machine Screw Jacks with Anti-Backlash and Anti-Rotation (Keyed)

Model		EMT0005	EMT0010	EMT0025	EMT0050	EMT0100	EMT0200	EMT0300	EMT0500	EMT1000	EMT1500	EMT2000
M	Mounting Plate	10	10	15	15	20	20	30	30	50	60	70
K	Stroke 0 → 150	70	75	80	110	-	-	-	-	-	-	-
	Stroke 0 → 300	90	95	80	120	105	135	140	238	405	-	-
	Stroke 301 → 500	-	-	-	-	-	-	-	-	-	Request	Request
	Stroke 301 → 500	90	95	105	130	130	160	165	263	405	-	-
	Stroke 501 → 1000	-	-	-	-	-	-	-	-	-	Request	Request
	Stroke 601 → 1050	-	-	130	150	130	160	165	288	430	-	-
	Stroke 1051 → 1500	-	-	130	170	155	185	190	313	455	-	-
	Stroke 1001 → 2000	-	-	-	-	-	-	-	-	-	Request	Request
Stroke 2001 → 4000	-	-	-	-	-	-	-	-	-	Request	Request	
L	Extra Closed Height for Clevis	20	20	25	25	45	45	40	50	65	Request	Request
N	Extra Closed Height for Fork	19	23	49	63	102	135	Request	Request	Request	Request	Request
P	Extra Closed Height for Rod End	37	40	60	72	98	122	Request	Request	Request	Request	Request

## Features

- Protects the screw from dust and dirt
- Guards against moisture and corrosive contaminants
- Helps maintain the proper lubrication
- Boots are made of P.V.C. coated nylon with sewn construction. Other materials are available for applications involving high temperatures, highly corrosive atmospheres and other special conditions.



## Boot Dimensions

Model	A	B	C	D	E
EBT0010	30	75	114	12	12
EBT0025	40	66	120	15	15
EBT0050	50	85	140	15	15
EBT0100	65	100	150	15	15
EBT0200	75	105	165	20	20

Model	A	B	C	D	E
EBT0300	110	150	180	20	20
EBT0500	Available on Request				

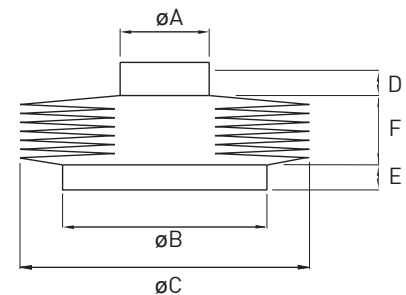

Model		EBT0010	EBT0025	EBT0050	EBT0100	EBT0200	EBT0300
F	Stroke 0 → 300	16	20	20	20	20	20
	Stroke 301 → 600	32	30	30	30	30	30
	Stroke 601 → 900	-	-	45	-	-	-
	Stroke 601 → 1050	56	50	-	50	50	50
	Stroke 901 → 1050	-	-	50	-	-	-
	Stroke 1051 → 1500	80	70	70	70	70	70

### Note

1. F = Bellows boot minimum closed thickness
2. - = Not applicable consult Power Jacks Ltd
3. † = Control tapes fitted (approximately 20 mm increase to outer diameter).
4. Supplied complete with a set of corrosion-resistant 'jubilee' clips (2) suitable for fitting over collar diameters.
5. For horizontal installation exceeding 450 mm of travel, internal boot guides are recommended.
6. Customers with threaded end screw jacks must provide a fixing for the unattached collar (★).
7. Bellows boots for rotating screw jacks consult Power Jacks Ltd.
8. For other sizes, strokes and materials please contact Power Jacks Ltd.
9. All dimensions in millimetres unless otherwise stated.
10. Dimensions subject to change without notice.
11. Screw Jack mounting plate and bellows boot mounting plate are usually all part of the customers superstructure (★ ★). For other options consult Power Jacks.

## Closed Heights

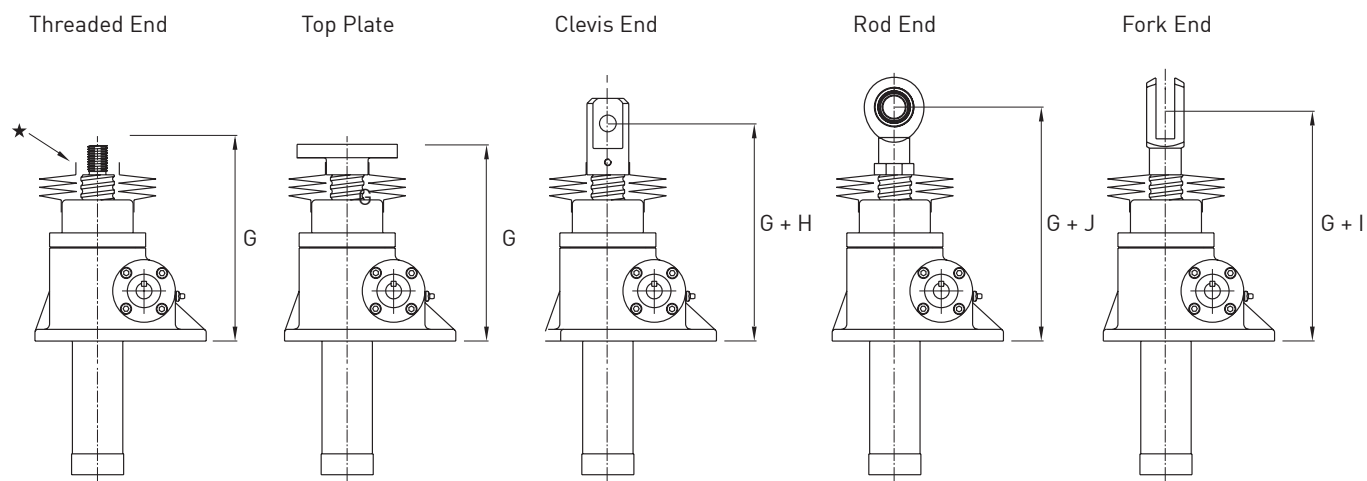

## Closed Height for all Upright Metric Ball Screw Jacks

Model	EBT0010	EBT0025	EBT0050	EBT0100	EBT0200	EBT0300					
Lead Option	1	1	2	1	2	1					
G	Stroke 0 → 300	166	180	200	230	270	255	285	348	396	470
	Stroke 301 → 600	182	190	210	240	280	265	295	358	406	480
	Stroke 601 → 900	-	-	-	255	295	-	-	-	-	-
	Stroke 601 → 1050	206	210	230	-	-	285	315	378	426	500
	Stroke 901 → 1050	-	-	-	260	300	-	-	-	-	-
	Stroke 1051 → 1500	230	230	250	280	320	305	335	378	446	520
H	Extra Closed Height for Clevis	20	25	25	25	25	45	45	45	45	40
I	Extra Closed Height for Fork	23	49	49	63	63	82	82	135	135	Request
J	Extra Closed Height for Rod End	43	60	60	72	72	98	98	122	122	Request

Closed Heights

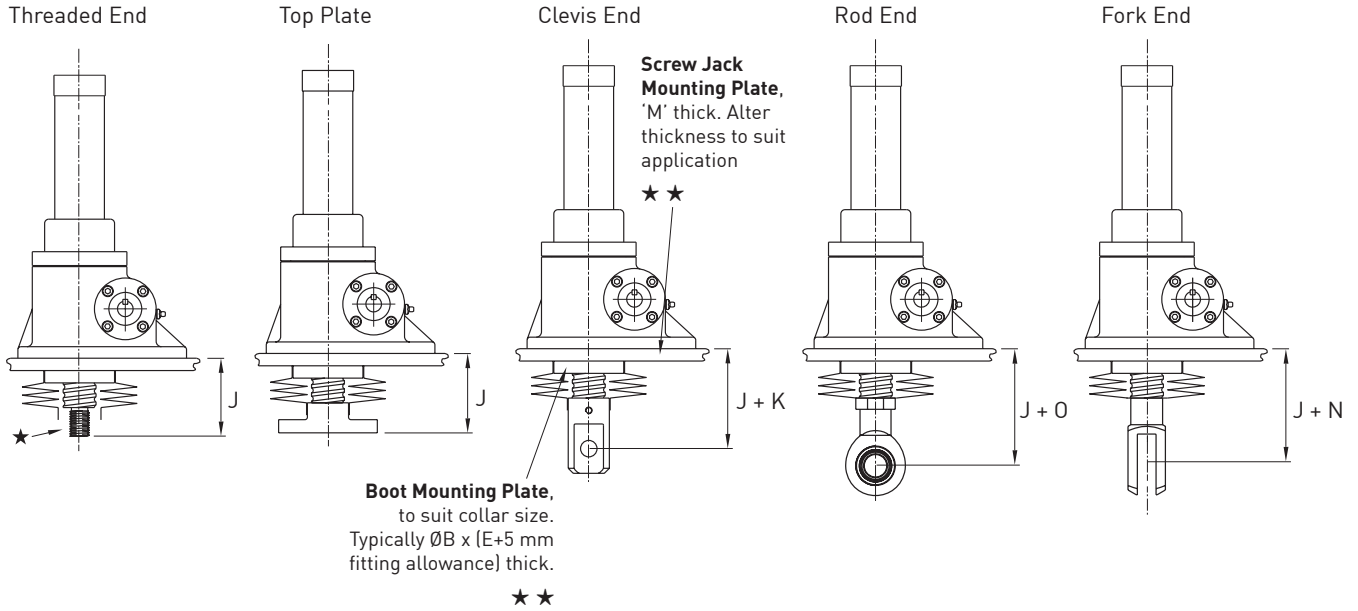

Closed Height for all Inverted Metric Ball Screw Jacks

Model	EBT0010	EBT0025		EBT0050		EBT0100		EBT0200		EBT0300	
Lead Option	1	1	2	1	2	1	2	1	2	1	
M Mounting Plate	10	15	15	15	15	20	20	20	20	30	
G	Stroke 0 → 300	61	100	100	105	105	120	120	140	140	135
	Stroke 301 → 600	77	110	110	115	115	130	130	150	150	145
	Stroke 601 → 900	-	-	-	130	130	-	-	-	-	-
	Stroke 601 → 1050	101	130	130	-	-	150	150	170	170	165
	Stroke 901 → 1050	-	-	-	135	135	-	-	-	-	-
Stroke 1051 → 1500				155	155	170	170	190	190	185	
K Extra Closed Height for Clevis	20	25	25	25	25	45	45	45	45	40	
N Extra Closed Height for Fork	23	49	49	63	63	82	82	135	135	Request	
O Extra Closed Height for Rod End	43	60	60	72	72	98	98	122	122	Request	



### Stop Nut

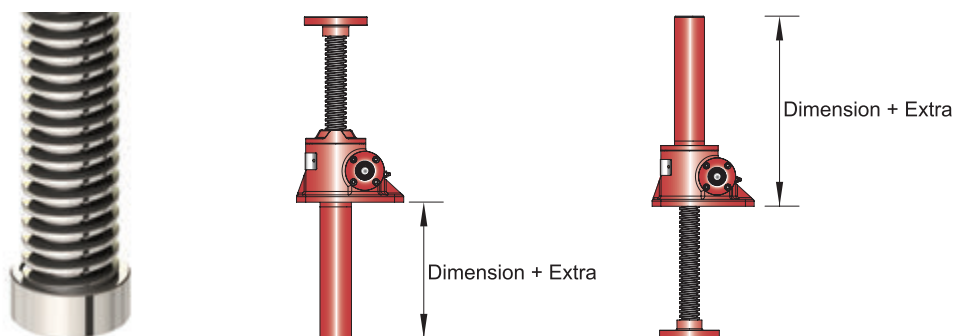

### Machine Screw Jack

Model	Extra (mm)	
	Upright	Inverted
EMT0005	16	11
EMT0010	15	50
EMT0025	20	20
EMT0050	40	40
EMT0100	42	37
EMT0200	41	31
EMT0300	55	35
EMT0500	47	47
EMT1000	72	92
EMT1500	160	210
EMT2000	9	84

### Ball Screw Jack

Model	Extra (mm)	
	Upright	Inverted
EBT0010	On Request	
EBT0025	30	30
EBT0050	57	57
EBT0100	60	60
EBT0200	56	56
EBT0300	On Request	
EBT0500	On Request	

**Note**

These are full power stop nuts. They should only be used as an emergency stop safety feature.

### Hand Wheels

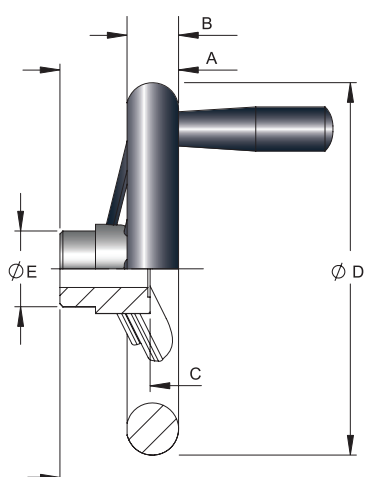

Model	A	B	C	D	E	H7 Bore
HW 005	40	14	36	98	24	Ø10
HW 010	50	22	38	157	32	Ø14
HW 025	56	24	43	198	40	Ø16
HW 050	56	24	43	198	40	Ø19
HW 100	66	30	44	247	49	Ø25
HW 200	78	32	56	288	58	Ø28
HW 300	108	40	77	375	58	Ø35
HW 500	108	40	77	375	58	Ø40

**Notes:**

1. Material: Polished aluminium casting and rotating handle
2. Bored and keyed to BS4235 Part 1
3. All dimensions in millimetres unless otherwise stated
4. Other types of hand wheels are available on request. Consult Power Jacks.

Base mounted trunnions are an ideal bolt-on accessory for a screw jack to add a pivot point to the gearbox of the screw jack. These base mounted trunnions can be used for both translating and rotating screw jacks with any lifting screw type.

Available in both male or female designs with the option to add standard trunnion feet. Most designs offer trunnions in 2 mounting positions.

If you need trunnions fitted at another position on a screw jack then please contact us as we can provide customised trunnion mounts to suit your exact applications needs



5kN and 10kN Trunnion Mounts

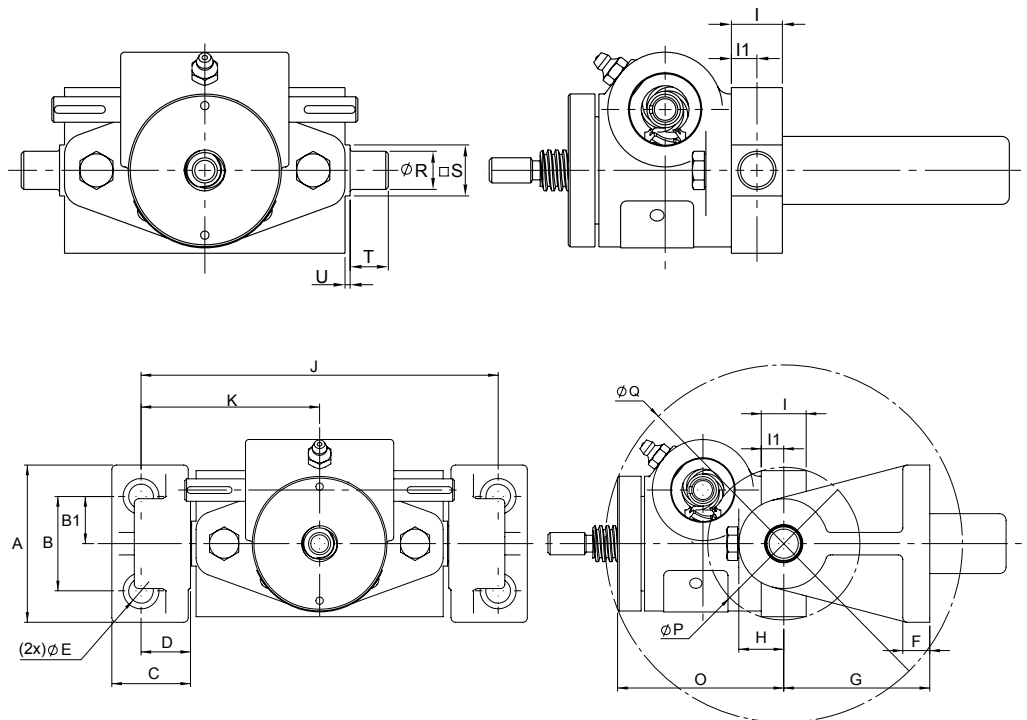

Capacity	A	B	B1	C	D	ØE	F	G	H	I	I1	J	K	O	P	Q	ØR (h6)	S	T	U
5kN	70	42	21	35	22	11	12	65	20	20	10	159	79.5	74	68	160	15	20	15	2
10kN	70	42	21	35	22	11	12	65	20	25	12.5	181	90.5	103	84	209	20	24	20	2.5

### 25kN to 500kN Trunnion Mounts

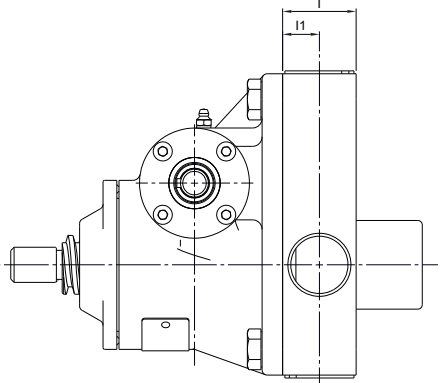
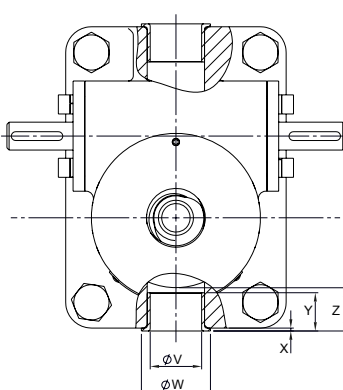
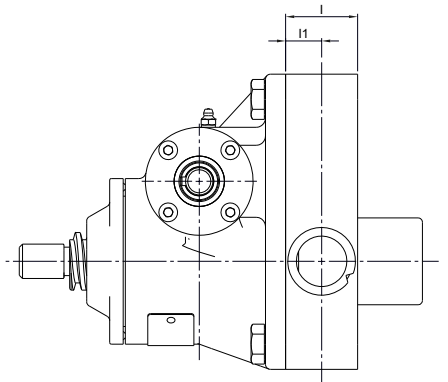
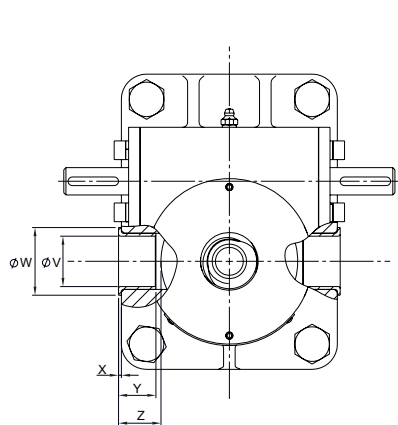
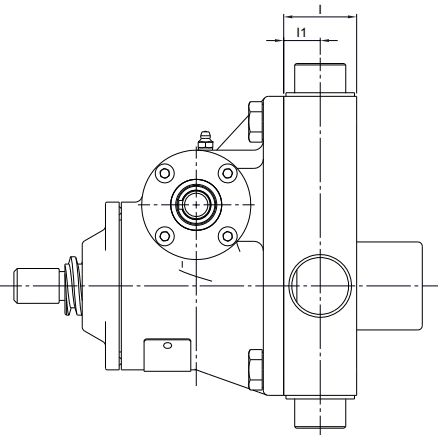
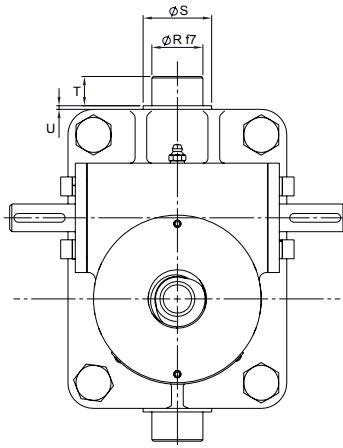
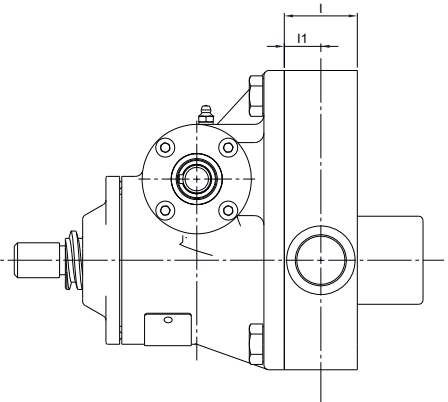
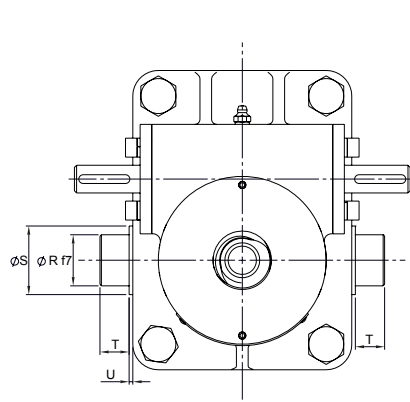

25kN to 500kN Trunnion Mounts

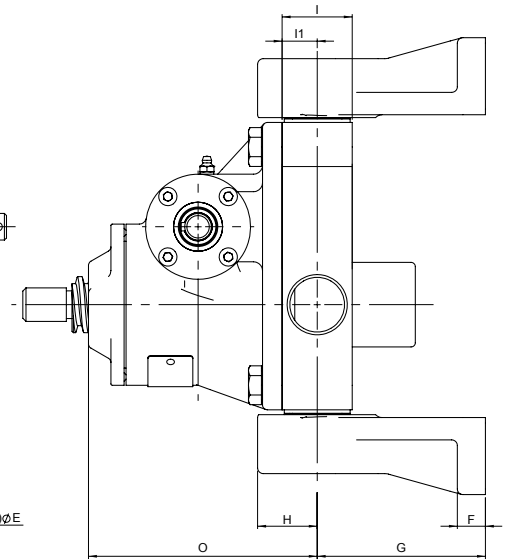
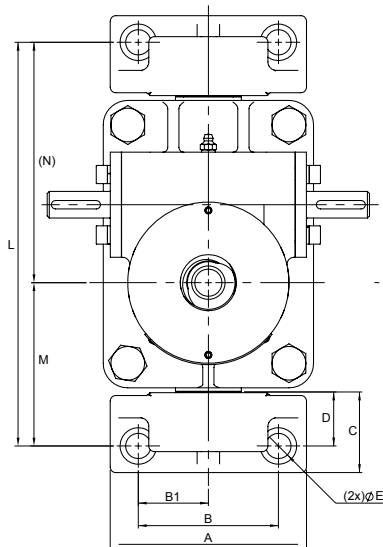
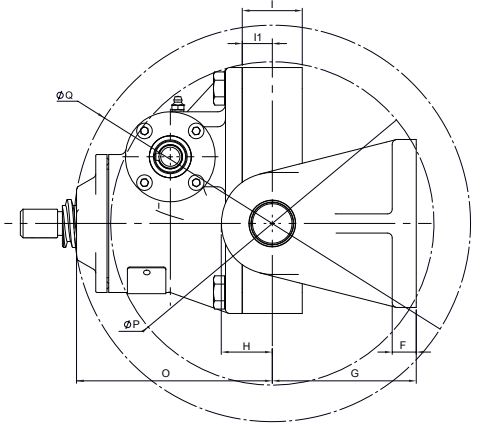
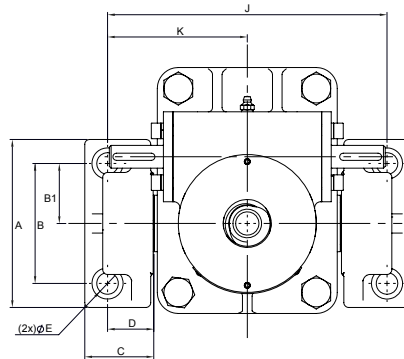

Capacity	A	B	B1	C	D	ØE	F	G	H	I	I1	J	K	L
25kN	100	70	35	40	26	13.5	14	85	30	36	18	171	85.5	226
50kN	140	100	50	55	35.5	18	20	120	42.5	50	25	233	116.5	288
100kN	170	120	60	70	43.5	22	25	130	47.5	60	30	292	146	327
200kN	220	150	75	90	61	33	25	170	59	85	42.5	344	172	409
300kN	280	190	95	120	80	39	35	180	60	100	45	434	217	539
500kN	360	250	125	155	100	51	40	200	70	120	55	514	257	749

Capacity	M	N	O	P	Q	ØR (f7)	S	T	U	V	W	X	Y	Z
25kN	95.5	130.5	121.5	208	248	25	35	20	2.5	25	35	1.5	16.5	26
50kN	116.5	171.5	163	270	332	35	47	20	2.5	35	47	2	26	39
100kN	126	201	177	312	361	45	58	35	5	45	74	2	32	40
200kN	172	237	238	361	500	60	75	45	5	60	78	2	42	45
300kN	227	312	280	473	578	70	85	70	6	70	90	3	53	58
500kN	332	417	330	643	681	80	95	70	6	80	110	2	62	62

### 1000kN to 2000kN Trunnion Mounts

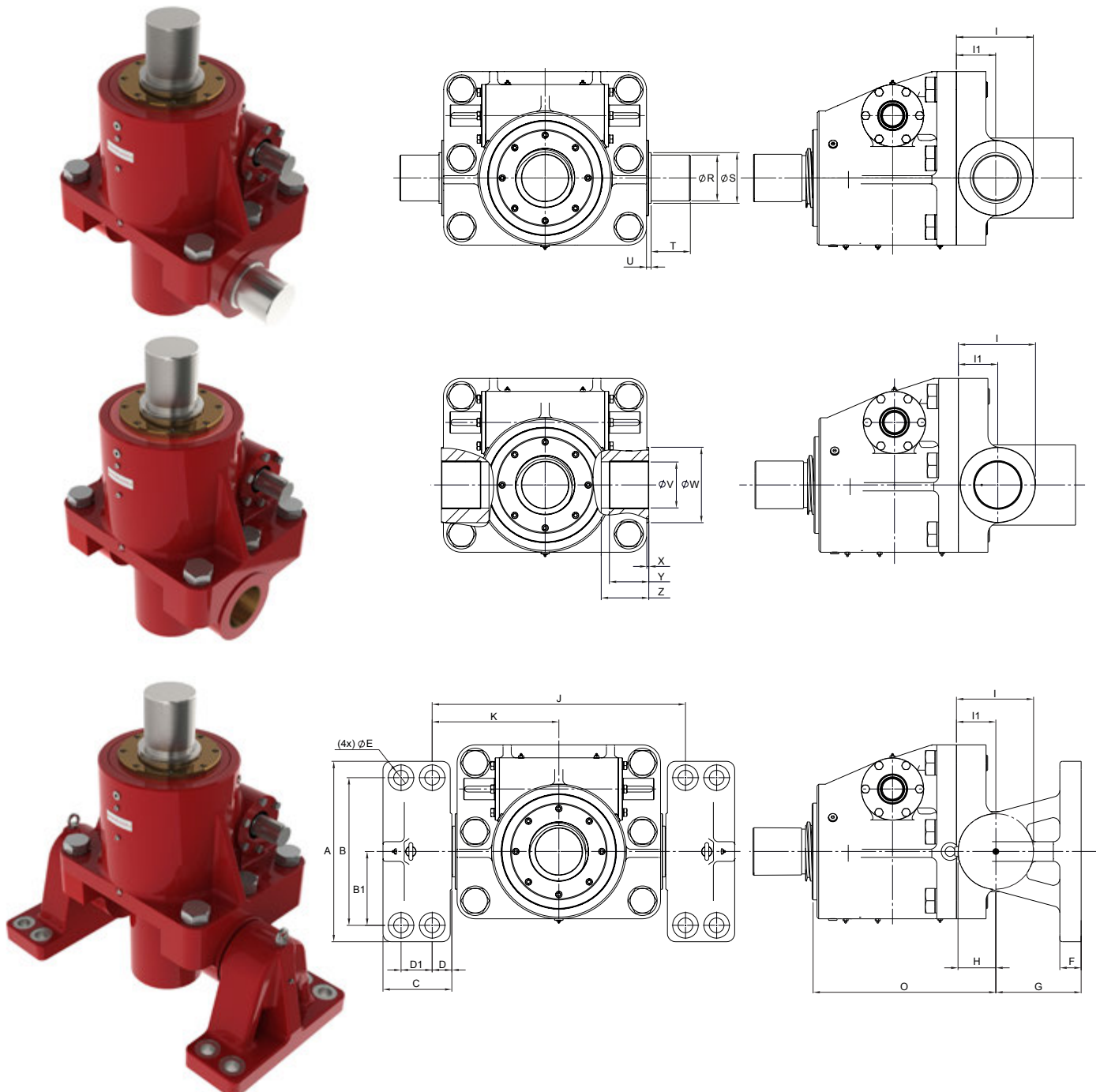

Note: Trunnion feet for 300kN and 500kN models are available on request

Capacity	A	B	B1	C	D	ØE	F	G	H	I	I1	J	K	L
1000kN	550	450	225	210	60	95	45	50	240	92.5	212.5	120	772	386
1500kN	550	450	225	210	60	95	45	65	260	115	235	120	772	386
2000kN	640	530	265	235	65	110	52	70	265	135	275	140	976	488

Capacity	M	N	O	P	Q	ØR (f7)	S	T	U	ØV	W	X	Y	Z
1000kN	N/A	N/A	525	725	1074	110	125	115	14	110	185	6	115	145
1500kN	N/A	N/A	560	758	1162	140	155	120	14	140	230	6	120	145
2000kN	N/A	N/A	626	1004	1295	160	180	145	11	160	270	3	145	148

- Standard adapters for 25 kN - 200 kN metric machine screw and ball screw jacks
- Designed for standard IEC frame sizes
- Allows direct motor coupling on either side of the screw jack input shaft
- Complete with drive coupling and mounting hardware

Note

- When direct coupling a motor to a screw jack, it is necessary to match motor power to screw jack load so the motor does not exceed the maximum power for the screw jack gear set.

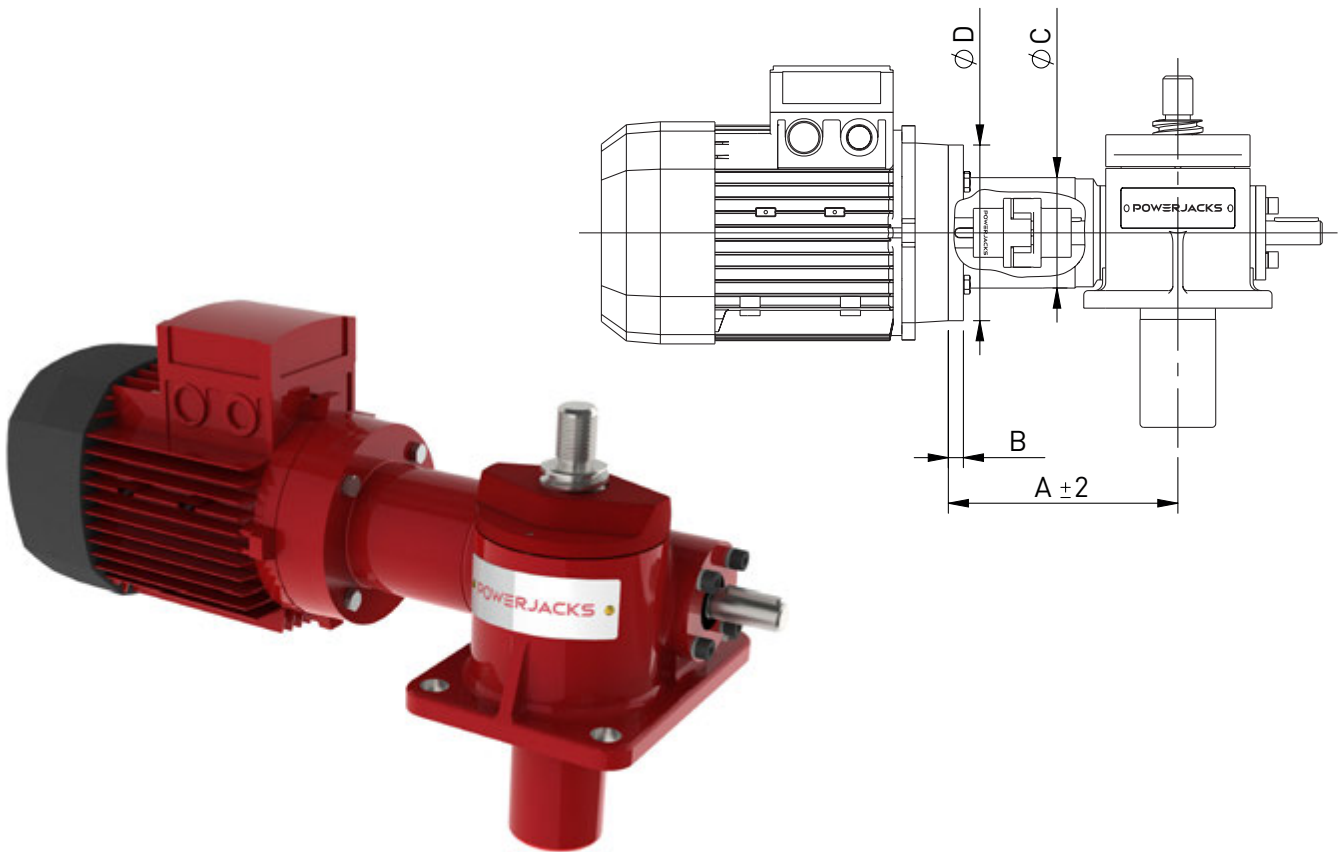

Motor Adapters		Capacity [kN]															
		25				50				100				200			
Frame Size	Motor Mounting	A	B	ØC	ØD	A	B	ØC	ØD	A	B	ØC	ØD	A	B	ØC	ØD
71	B14 C105	142.5	10	71	105	-	-	-	-	-	-	-	-	-	-	-	-
80	B14 C120	146.5	12	81	120	171	12	86	120	-	-	-	-	-	-	-	-
90	B14 C140	157.5	12	81	140	183	12	88	140	208	12	98	140	218	12	125	140
100	B14 C160	168	12	81	160	193	12	88	160	218	12	98	160	228	12	125	160
112	B14 C190	168	12	81	160	193	12	88	160	218	12	98	160	228	12	125	160
132	B14 C200	-	-	-	-	218	14	95	200	240	14	98	200	250	14	125	200

Notes:

1. Motor Adapters for IEC Frames with B5 Flange mounts available on request.
2. Motor Adapters for screw jacks of capacities 300kN and above are available on request.
3. Adapters for geared motors are available on request for all types of geared motor or gear head.
4. Motor Adapters for Servo Motors available on request.
5. Motor Adapters for NEMA Frame motors are available on request.
6. All dimensions in millimetres unless otherwise stated.
7. Dimensions subject to change without notice.



## End of Travel Proximity Sensors Sensor Kit

- Inductive Proximity Sensors as standard, others available on request.
- No contact so no wearing parts.
- 2 wire sensor for either Normally Closed (NC) or Normally Open (NO) switching.
- Sensor has rugged one-piece metal housing.
- Optical setting aid with 2 LED colour settings:- Red LED indicates just in sensing range. Yellow LED only indicates within 80% safe sensing range.
- M12 plug in connection for fast change-ability.
- M12 sockets available straight or angled with 5-m cable (other cable lengths available on request).
- Full 360° visibility for switching with 4 yellow LED's at 90° offset.
- Sensor kit includes - sensor, mounting ring, target ring and modification to screw jacks cover pipe.

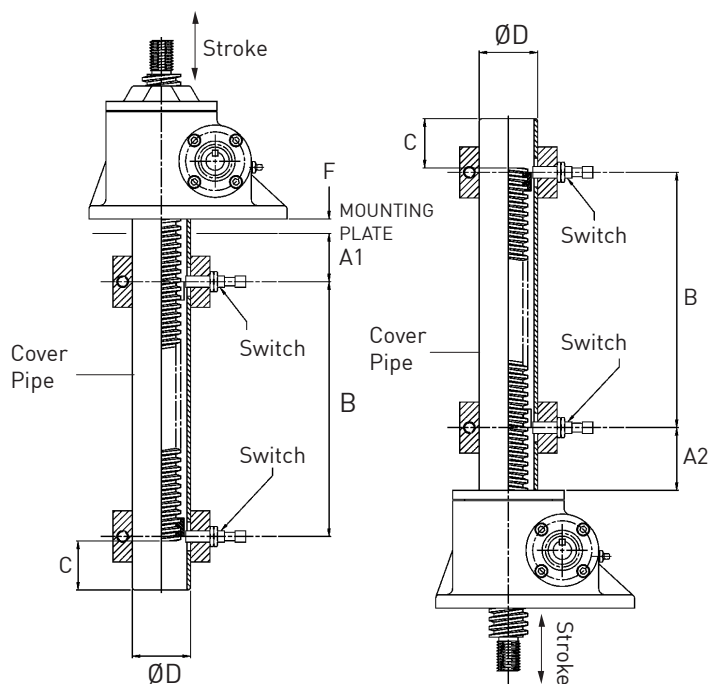

Upright & Inverted Machine Screw Jacks								
Capacity Rating (kN)	Switch Dia (mm)	A1 (mm)	A2 (mm)	B (mm)	C (mm)	D (Ømm)	F (mm)	Switch Adjustment (mm)
5	8	40	40	Stroke + 12	38	33.4	10	±5
10	8	40	40	Stroke + 20	40	33.4	10	±5
25	12	35	60	Stroke + 15	60	48	15	±5
50	12	40	70	Stroke + 25	65	60	15	±5
100	12	55	85	Stroke + 25	77	73	20	±10
200	12	65	80	Stroke +25	77	89	20	±10
300	18	65	80	Stroke +40	96	141	30	±10
500	18	95	95	Stroke +40	108	168	30	±15
1000	18	155	105	Stroke +50	135	245	50	±15
1500	On Request							
2000	On Request							



### Note

1. All dimensions in mm unless otherwise stated.

## End of Travel Electro-Mechanical Switches

The screw jacks can be fitted with electro-mechanical limit switches in a similar design. For dimensions please consult Power Jacks Ltd.





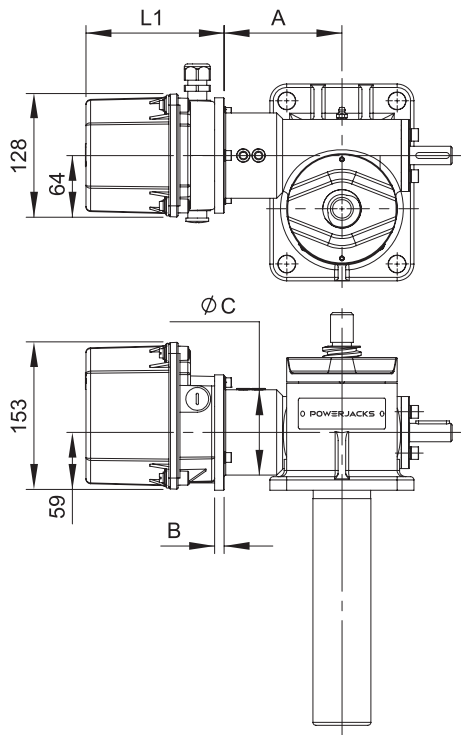

Rotary limit switches can be used as end of travel limit switches, with the option of intermediate switches as well. These units are mounted onto a screw jacks free worm shaft and offer an alternative where bottom pipe mounted limit switches are not possible e.g. rotating screw jacks. Up to 8 limit switches can be accommodated in one enclosure (IP66). Operating temperature -40°C to +80°C.

More RLS-51 rotary limit switch details in System Components section of design guide

Screw Jack Capacity (kN)								
		25			50			
Adapter Mounting	Std. Part	A	B	ØC	Std. Part	A	B	ØC
B5	x	-	-	-	x	-	-	-
B14	✓	117	10	70	✓	133	10	89

Screw Jack Capacity (kN)								
		100			200			
Adapter Mounting	Std. Part	A	B	ØC	Std. Part	A	B	ØC
B5	✓	150	13	98	✓	174	13	125
B14	x	-	-	-	x	-	-	-

The mounting kit includes the flexible coupling and drive adapter.

Gear Size	Usable revs. selected	Usable revs. theoretical with 15° cam discs	Gear Ratio	1 rev. of the drive shaft - corresp. to an ang. motion of cam disc =°	Change - over contact reset rev. at driving shaft	Max drive speed (RPM)	Min drive shaft speed (only for change - over contact)	L1 (mm)			
								Limit Switches			
								2	4	6	8
1	4.1	4.16	4.285	84	0.00714	1000	0.67	132	132	157	157
	6.5	6.88	7.083	50.8	0.0118	1200	1.1				
	11	11.23	11.56	31.14	0.0193	1500	1.8				
2	17.5	17.84	18.361	19.6	0.0306	1800	2.9	132	132	157	182
	29	29.5	30.35	11.86	0.0505	1800	4.7				
	48	48.13	49.538	7.27	0.0825	1800	7.7				
3	75	76.45	78.678	4.57	0.131	1800	12.2	132	132	157	182
	125	126.39	130.054	2.77	0.2166	1800	20.2				
	205	206.26	212.272	1.69	0.3536	1800	33				
4	323	327.6	337.135	1.06	0.5616	1800	52	132	157	182	207
	540	541.5	557.284	0.65	0.9284	1800	87				
	880	883.8	909.59	0.4	1.515	1800	141				
5	1384	1403.7	1444.62	0.25	2.406	1800	224	132	157	182	207
	2288	2320.2	2387.96	0.15	3.978	1800	371				
	3735	3787.1	3897.58	0.09	6.493	1800	606				
6	5900	6014.77	6190.204	0.06	10.313	1800	*	157	157	182	207
	9800	9942.2	10232.407	0.04	17.047	1800	*				
	16000	16227.6	16701.17	0.02	27.824	1800	*				

Note

1. More than 8 contacts on request.
2. Dimensions with more than 8 contacts and with special executions, eg. potentiometer, on request.
3. RLS-51 B5 Flange thickness = 4mm.
4. Options available include Anti-condensation heaters, potentiometer, pulse transmitter, encoder, aluminium housing and VBG-70 STAGE technology.
5. Mounting kits available for all screw jacks. For those not listed, consult Power Jacks.

## Special Designs

OUR SCREW JACK  
DESIGNS ARE FULLY  
CUSTOMISABLE BY OUR  
ENGINEERING TEAM SO  
YOUR APPLICATION CAN  
BE THE BEST.

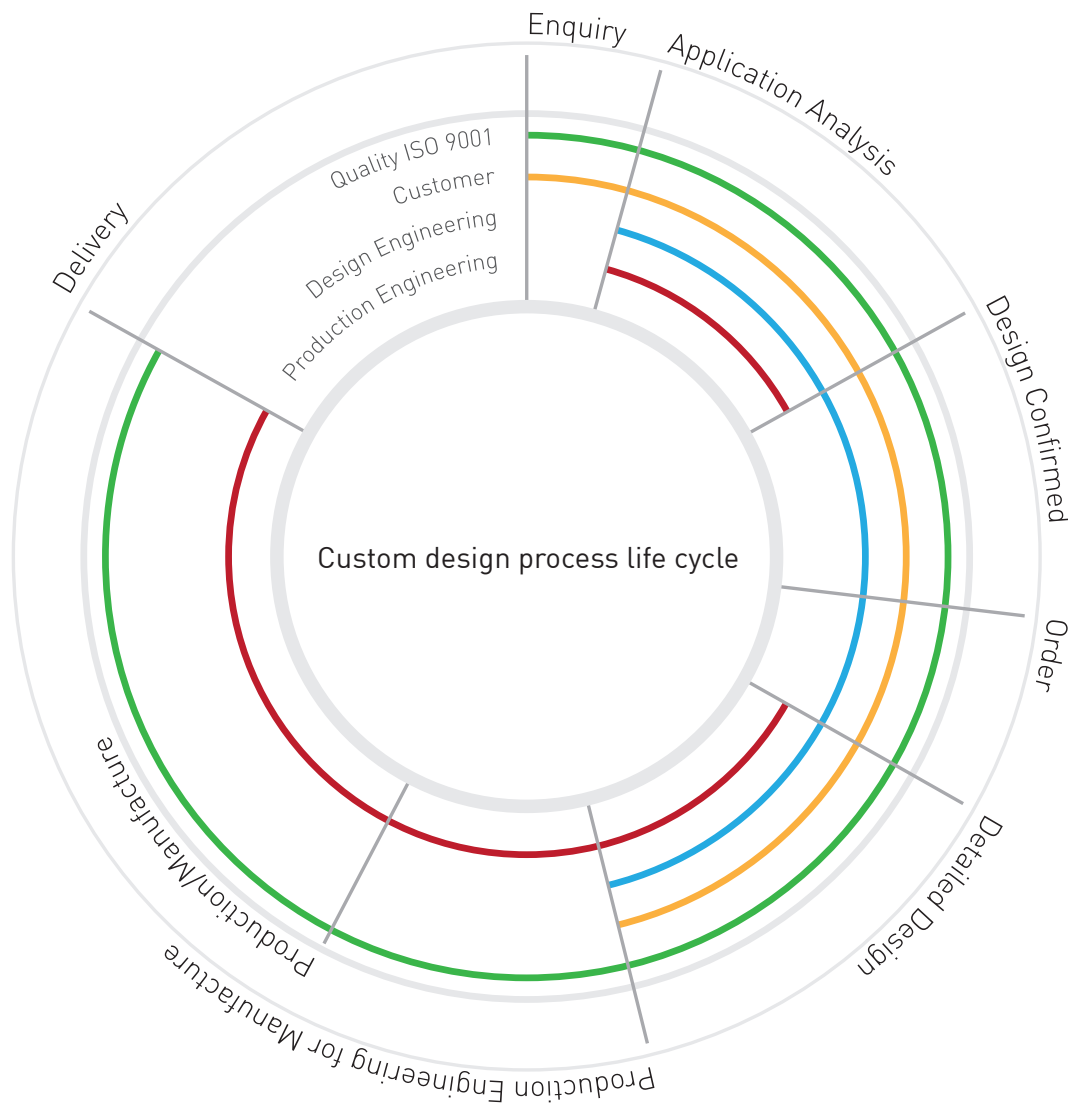

## Customised Products

For Power Jacks, every order is different.

We're ready every time to assess the precise requirements of the customer and formulate the right solution.

Off-the-shelf solutions are the norm for many engineering companies. And while they're certainly options for our customers, that's only the case if they're precisely the right options.

We pride ourselves on our adaptability – on our readiness to customise basic models, or even to start from scratch, so that we're providing products that offer optimum performance.

It's a customising service across our entire range of products that means customers get exactly what they need.

Special screw jack design are divided into 4 categories:

1. E-Class - simple customisation
2. SE-Class - enhanced design for specific performance.
3. HSE-Class - highly enhanced design for specialised performance.
4. XSD - extreme special designs for highly specialised performance.

### E Class Special Design

Enhances screw jack design by making simple customisation and feature additions. Examples include (but not limited to): Non-Standard Paint, Non-Standard Plating, Non-Standard Lubrication, Non-Standard Seals, Non-Standard Motor Adapter, Plating of Screw Jack Gearbox Housing, 3-Start Thread on Lifting Screw for increased lead, Special Closed Height for Screw Jack, Extended Worm Shaft, etc..

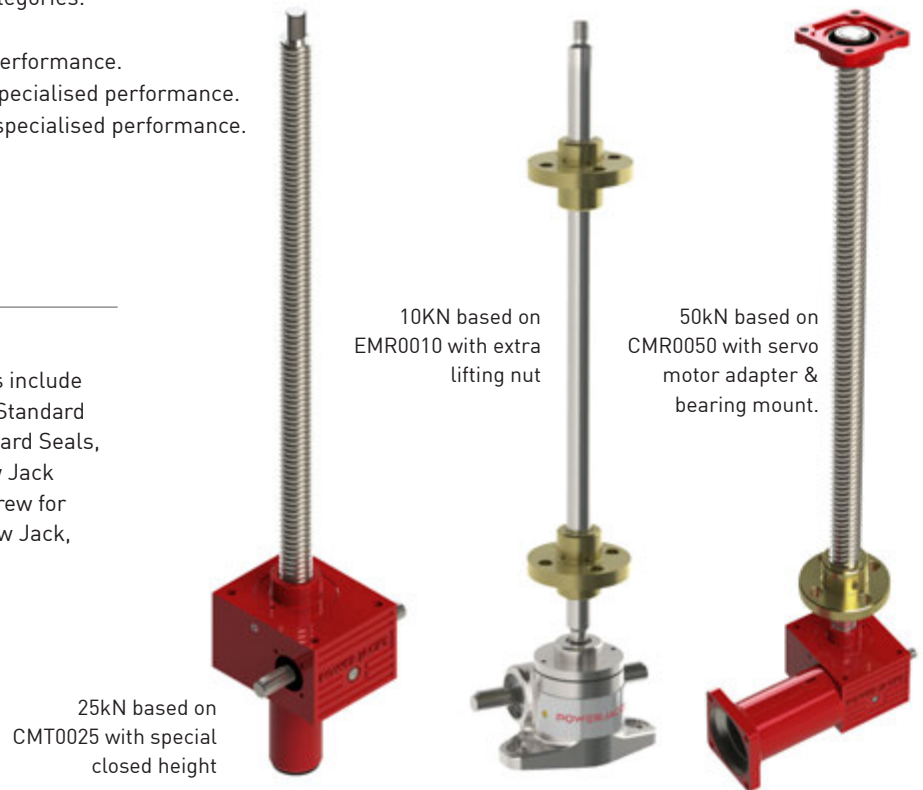

### SE Class Special Design

Special Enhancements to screw jack designs where new parts and/or accessories are used to deliver the best performance for the application. Examples include (but not limited to): Integration of Brake to Screw Jack Body, Bespoke End Fitting on Lifting Screw, Lifting Nut with Square Flange, Non-Standard Worm Shaft Design, Cover Pipes on Rotating Screw Jack, etc.

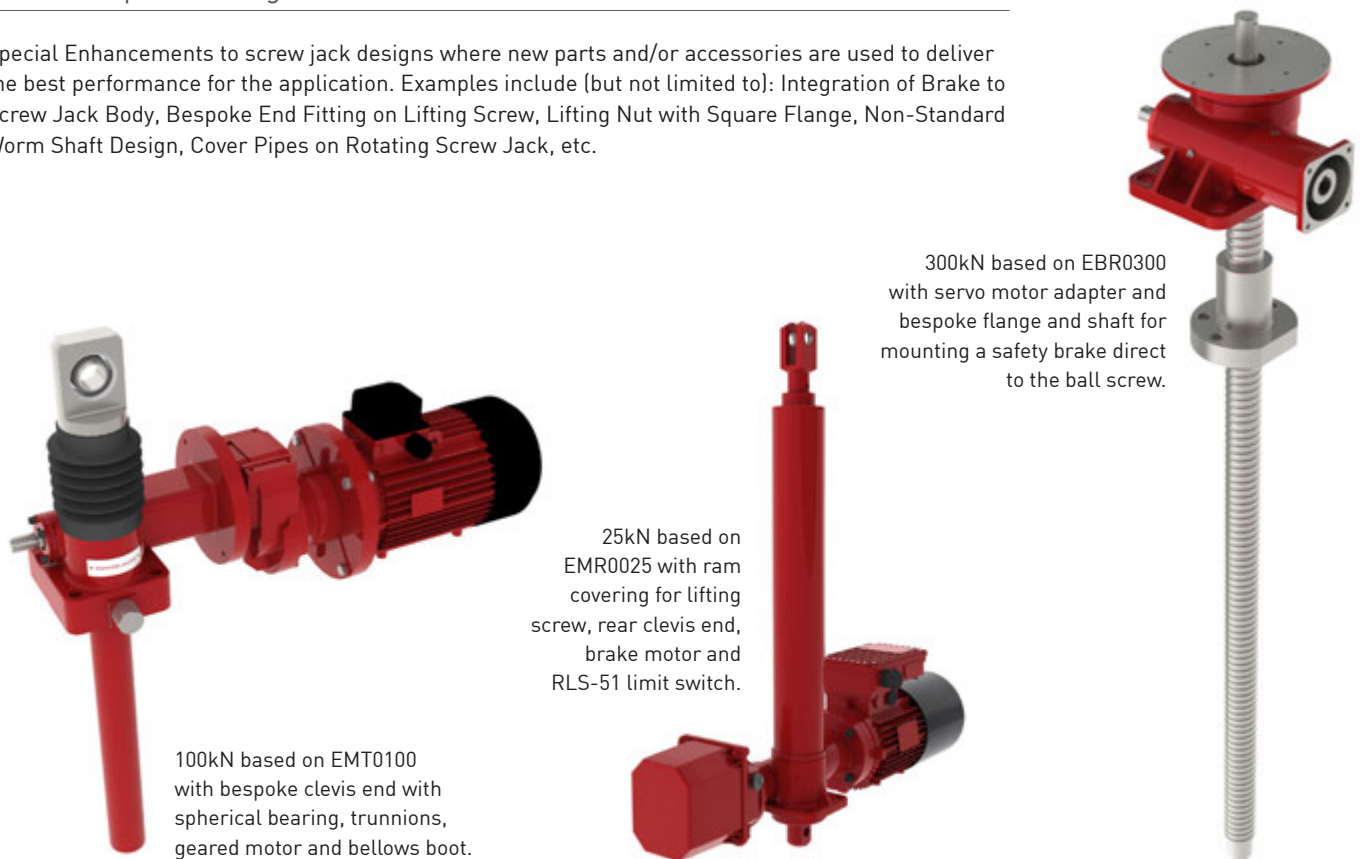

HSE Class Special Design

High Specification Enhancements to screw jack design where significant changes are made to main screw jack design and/or new and/or specialised accessories are integrated. Examples include (but not limited to): Bespoke Clutch on Worm Shaft, Coil Spring Load Limiter, Centre of Gravity Balanced Designs, Bespoke Trunnion Mounts, Telescopic Lifting Screw, Lifting Screw with Left & Right Threaded Sections, Increased Base Thickness for Screw Jack Gearbox Housing etc..



2000kN Based on EMT2000 with bespoke clutches for drives, geared motor integration, monitoring sensors, centre of gravity counter balance and bellows boot.



50kN based on EMT0050 complete stainless steel subsea screw jack with bespoke ROV interface.



200kN based on EMT0200 with bespoke trunnion mount, integrated motor and RLS-51 limit switches, customised fork end and bellows boot.

XSD Class Special Design

eXtreme Special Design for screw jacks where a modification of our existing range is not practical for engineering and/or commercial goals. The way to get the best performance for the application is to design and manufacture a unique product using our state of the art screw jack technology. Examples include (but not limited to): Seismic Rated 3500kN Nuclear Screw Jacks, Large Valve Control Mechanisms, 200degC rated Screw Jacks, Ultra Light Weight Screw Jacks for mobile applications, Solar Tracking Screw Jacks



3500kN Seismic rated Nuclear Screw Jacks complete special design for translating and rotating machine screw jacks.

Note  
Units are not to scale on illustration

## U-Series Underwater / Subsea Screw Jack Overview

The U-Series subsea screw jacks are a proven and reliable technology for subsea lifting, positioning and actuation solutions down to a depth of 3000m. They are used in a wide variety of underwater applications in the oil & gas sector. Each submersible variant is tailored exactly to the customer application.



Rotating Screw, Upright



Rotating Screw, Inverted



Translating Screw, Upright



Translating Screw, Inverted

- Proven depth ratings up to 3000m subsea as standard (deeper on request)
- Pressure compensated or flooded designs available
- Capacities up to 2000 kN (200Te) as standard
- Capacities up to 35000 kN (3500Te) on request
- Machine Screw Jacks
- Translating and rotating screw configurations
- Full stainless steel Screw Jacks
- Self-locking (the products only use power when moving)
- Anti-rotation mechanism for unconstrained loads
- Anti-backlash mechanism for axial positioning
- Option for reinforced shaft design for up to 300% higher torque transmission
- Reinforced sealing
- Dual nut (safety nut) fail safe load-holding option
- Shock load rated units
- Full range of anti-corrosion options
- ROV drive interfaces
- Low (-65°C) to High (+250°C) temperature solutions available
- Vibration resistant designs
- Full range of feedback devices for speed, position, rotation, wear and load monitoring control
- Special custom designs available to meet your exact requiren

U-Series Screw Jacks can be connected together in jacking systems so that multiple units can be operated and controlled together.

For more details request the U-Series brochure from Power Jacks or download a copy from [www.powerjacks.com](http://www.powerjacks.com)



## U-Series Subsea Screw Jack Performance

## Full Stainless Steel Construction

Model		UM-0025	UM-0050	UM-0100	UM-0200	UM-0300	UM-0500	UM-1000	UM-1500	UM-2000
Capacity (kN)		25	50	100	200	300	500	1000	1500	2000
Lifting Screw <sup>note1</sup>	Diameter X Pitch (mm)	30 x 6	40 x 9	55 x 12	65 x 12	95 x 16	120 x 16	160 x 20	Available on Request	
Gear Ratios	Option 1	6:1	6:1	8:1	8:1	10 <sup>2</sup> / <sub>3</sub> :1	10 <sup>2</sup> / <sub>3</sub> :1	12:1		
	Option 2	24:1	24:1	24:1	24:1	32:1	32:1	36:1		
Turn of worm for raise of lifting screw	Option 1	1 for 1mm	1 for 1.5mm	1 for 1.5mm	1 for 1.5mm	1 for 1.5mm	1 for 1.5mm	3 for 5mm		
	Option 2	4 for 1mm	4 for 1.5mm	2 for 1mm	2 for 1mm	2 for 1mm	2 for 1mm	9 for 5mm		
Maximum Input Power (kW)	Option 1	1.5	3	3.75	3.75	6	11.25	18.5		
	Option 2	0.375	0.55	1.125	1.125	1.9	4.5	8.25		
Start up Torque at full load (Nm) <sup>note2</sup>	Option 1	19.8	56	115.9	263.8	480	900	2025		
	Option 2	8.7	25.5	60.5	137	284	504	1119		
Weight (kg) – stroke = 150mm	UMT	8.45	14.9	24.3	42.4	92.4	183.7	459.1		
	UMR	8.85	16.54	28.8	49.58	113.78	224	560.4		
Weight (kg) per extra 25mm	UMT	0.21	0.32	0.58	0.84	1.55	2.48	4.11		
	UMR	0.11	0.19	0.36	0.52	1.13	1.94	3.38		
Option 1	Gear Ratio	6:1	6:1	8:1	8:1	10 <sup>2</sup> / <sub>3</sub> :1	10 <sup>2</sup> / <sub>3</sub> :1	12:1		
	Screw jack Static Efficiency	0.201	0.213	0.206	0.181	0.149	0.132	0.131		
	Screw jack Dynamic Efficiency	0.264	0.281	0.272	0.242	0.205	0.181	0.178		
Option 2	Gear Ratio	24:1	24:1	24:1	24:1	32:1	32:1	36:1		
	Screw jack Static Efficiency	0.115	0.117	0.132	0.116	0.084	0.079	0.079		
	Screw jack Dynamic Efficiency	0.167	0.172	0.190	0.169	0.128	0.120	0.123		
Standard Depth Rating	m	3000	3000	3000	3000	3000	3000	3000	3000	
Flooded Design Available		Y	Y	Y	Y	Y	Y	Y	Y	
Pressure Compensated Design Available		Y	Y	Y	Y	Y	Y	Y	Y	

## Notes:

1. All metric machine screws have a trapezoidal thread form, single start as standard (diameter x pitch)
2. For loads of 25% to 100% of Screw Jack capacity, torque requirements are approximately proportional to the load
3. Efficiency values for standard grease lubricated worm gear box and lifting screw
4. For performance of anti-backlash and anti-rotation (keyed) models, consult our Power Jacks experts

## Standard construction:

5. Stainless steel Screw Jack rated for rated capacity in tension or compression for static or dynamic movement
6. Lubrication = EP2 Grease
7. Paint finish = Power Jacks Standard Subsea Yellow (other colours available on request)
8. Other materials, plating and paint specifications are available to suit all applications and budgets

Please supply depth rating required with enquiry





## GRAPHITE HANDLING MACHINE

The Graphite Handling system was developed to retrieve graphite components, capping pieces and thermocouples from inside nuclear reactors, crush them for size reduction and deposit them into shielded flasks. The machine houses 4 types of flask.

The Crusher Jaws are driven by three 50 kN E-Series Ball Screw Jacks, complete with Bevel gearbox, brake and motor, to size reduce the component. The selected Flask is raised into the docking position by two more 50kN screw jacks, driven by a single electric motor via bevel gearboxes. The size reduced component is deposited into the flask and the flask is returned to its storage position.

For more application examples see the 'Power at Work' brochure or [www.powerjacks.com](http://www.powerjacks.com).



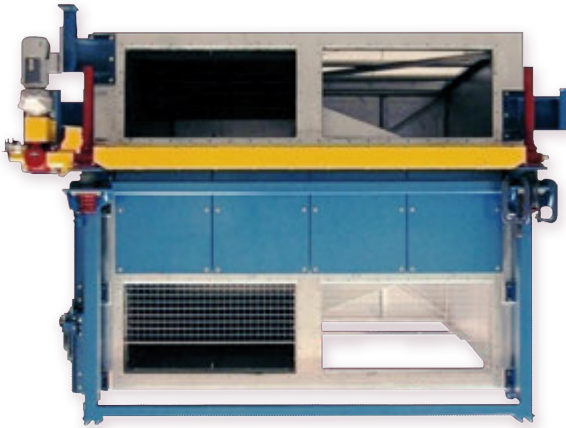
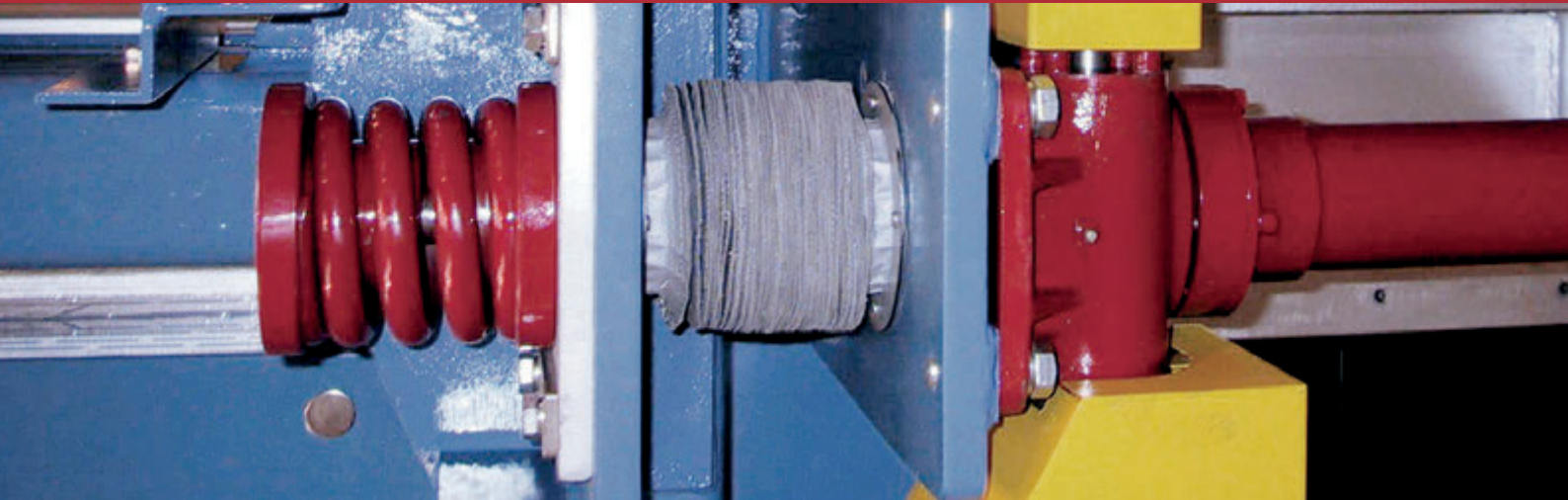

## COIL SPRING LOAD LIMITER

When an industrial machine needs to move a cover or lid onto a dead stop or sealing face it must do so precisely and positively, with contact on all dead stops or over the complete sealing face.

To push the cover into position precisely Power Jacks designed a special coil spring load limiter for the end of the jacks lifting screw.

For more application examples see the 'Power at Work' brochure or [www.powerjacks.com](http://www.powerjacks.com).



## ENGINEERING GUIDE

# USEFUL PERFORMANCE & OPERATIONAL DETAIL FOR SCREW JACKS

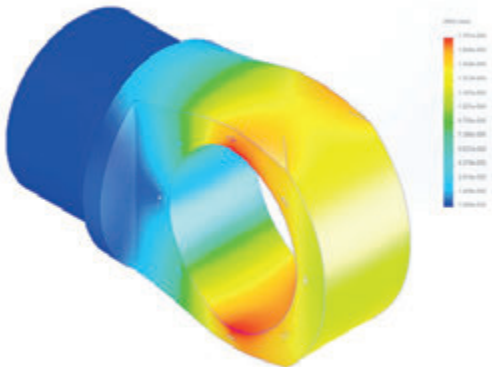
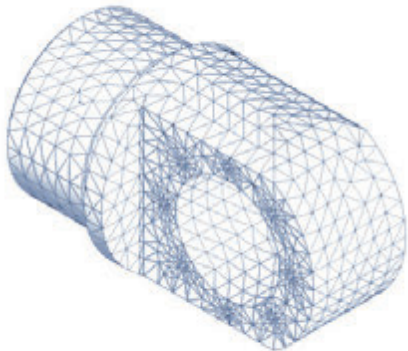
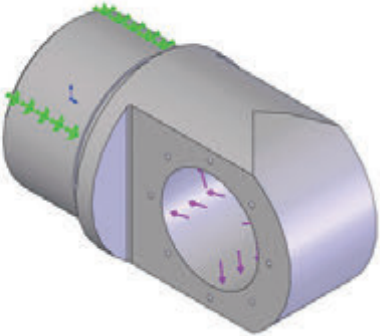
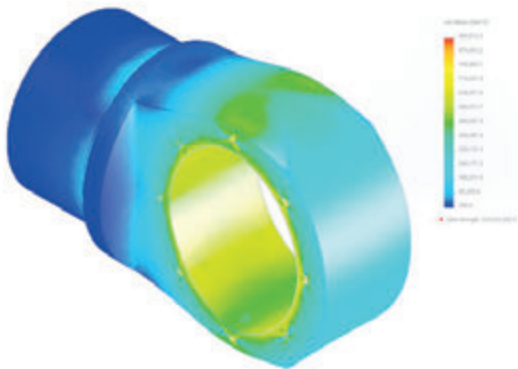

**Important Notes**

1. All charts are rated for industrial cargo with a safety factor of 3.5.
2. For human cargo a safety factor of 5 is recommended. To alter the permissible compressive load (WP) for human cargo multiply the load selected from the chart by 0.7 e.g.  $W_{PHC} = W_P * 0.7$ .

Column Length Correction Factors,  $F_{cb}$

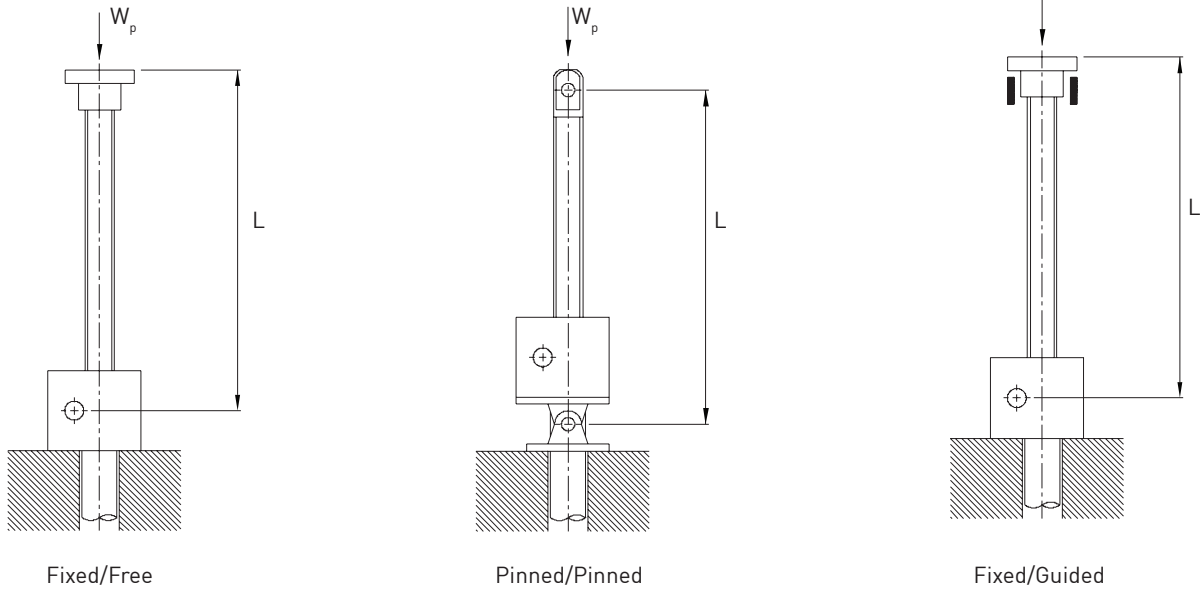

2.5kN MACHINE SCREW JACK

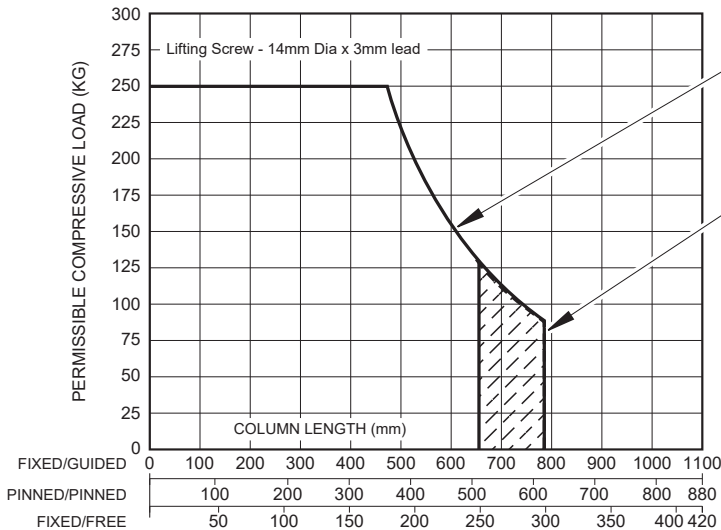

Euler Buckling Curve

Column strength cut off point due to slenderness ratio considerations



**Applications in hatched area - consult Power Jacks Ltd for detailed analysis.**

5kN MACHINE SCREW JACK

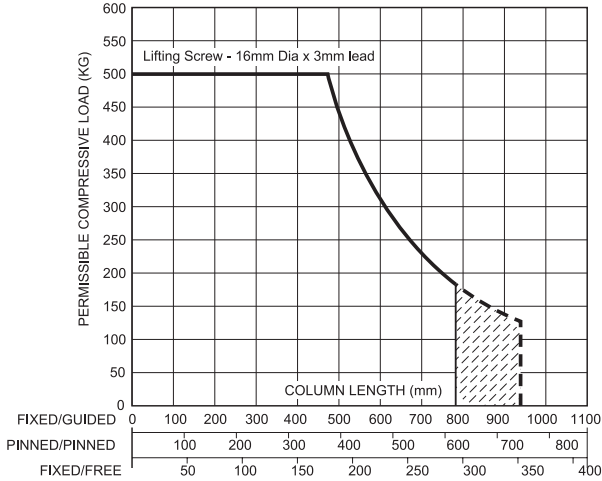

10kN MACHINE SCREW JACK

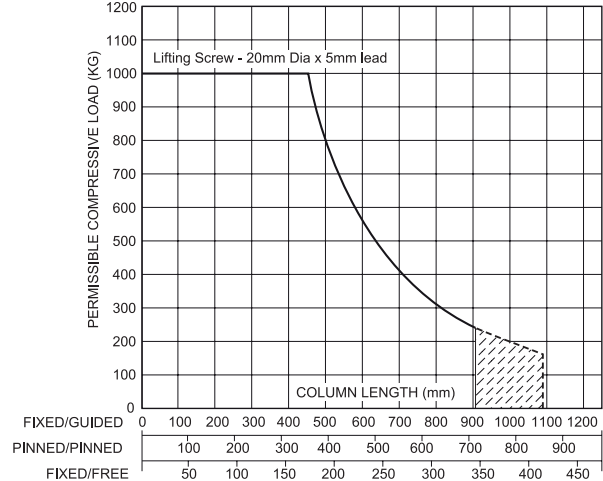

25kN MACHINE SCREW JACK

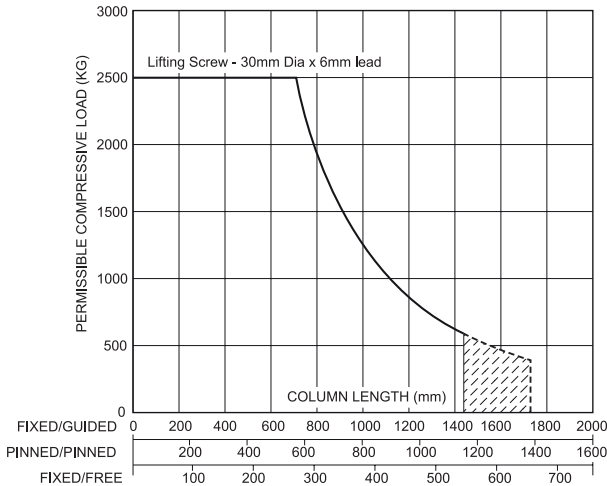

50kN MACHINE SCREW JACK

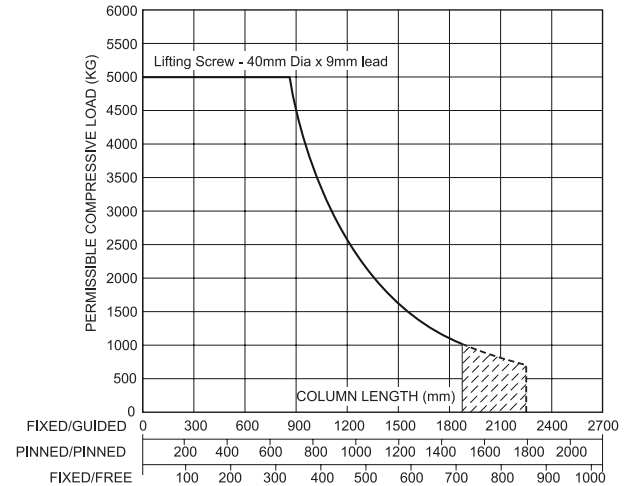

100kN MACHINE SCREW JACK

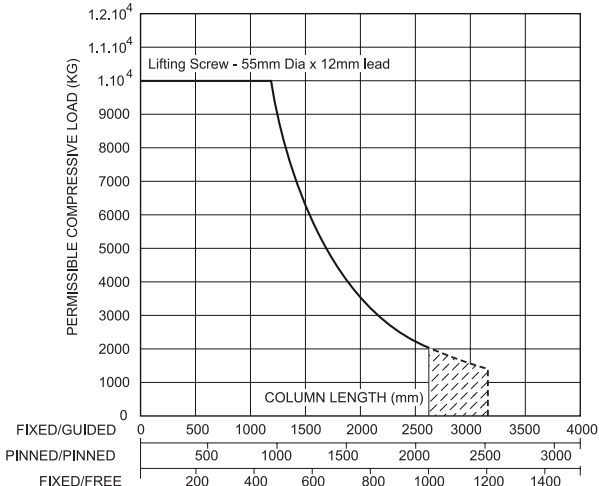

200kN MACHINE SCREW JACK

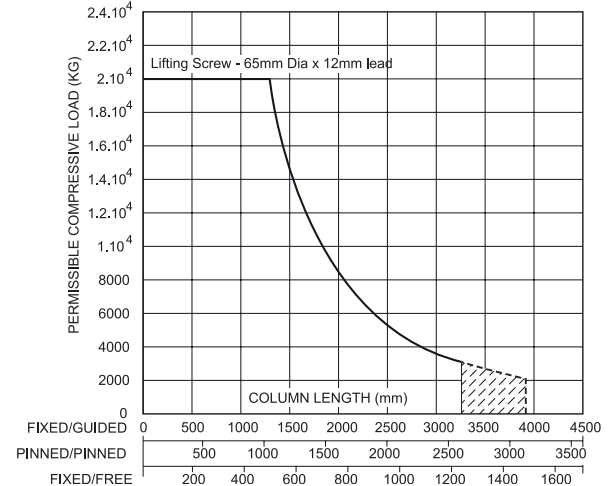

Note

1. Column end constraints based on A.I.S.C. recommended values
2. All screw jack column strength charts show a Euler buckling curve and three scales for the appropriate end condition for the application under analysis.

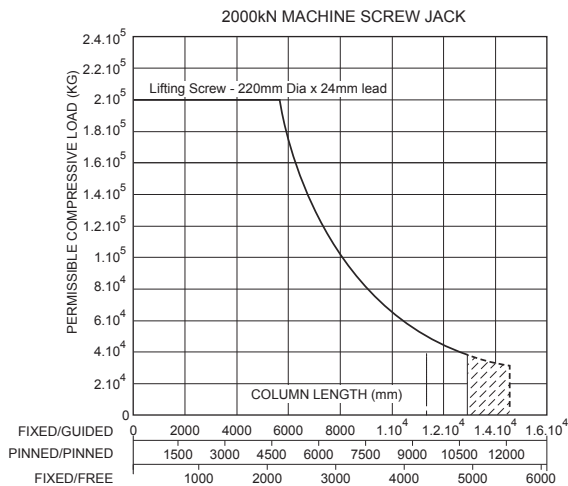
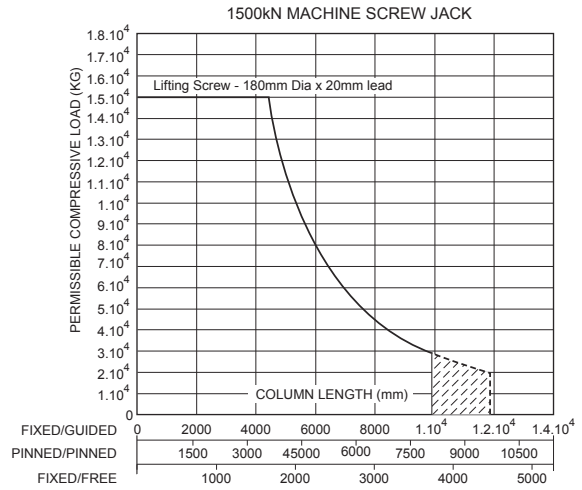
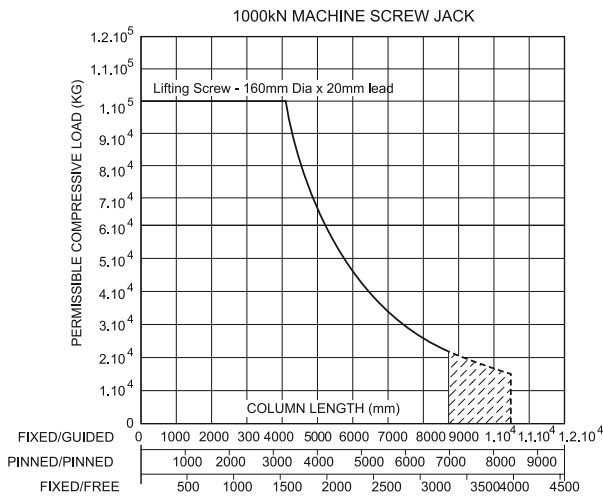
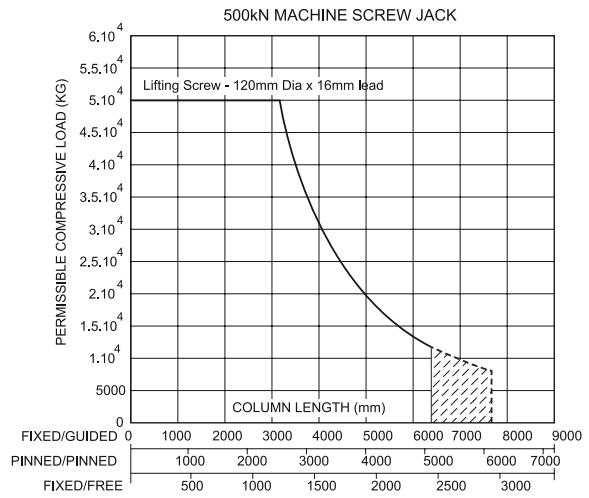
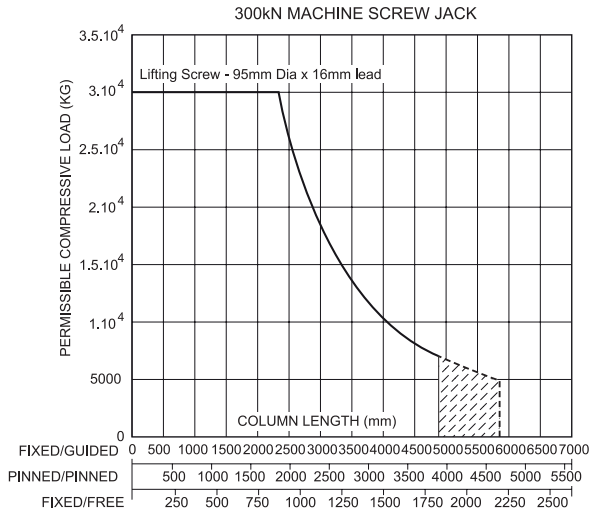

**Note**

1. Column end constraints based on A.I.S.C. recommended values
2. All screw jack column strength charts show a Euler buckling curve and three scales for the appropriate end condition for the application under analysis.



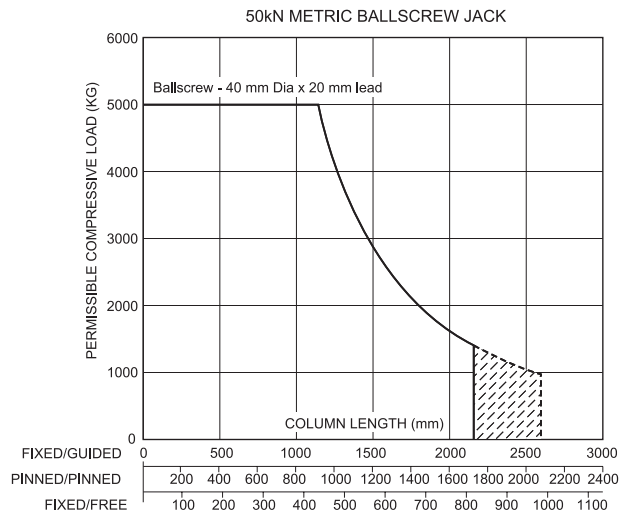
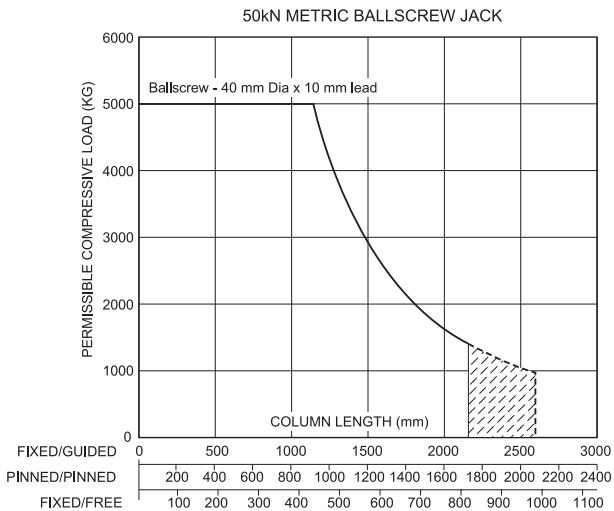
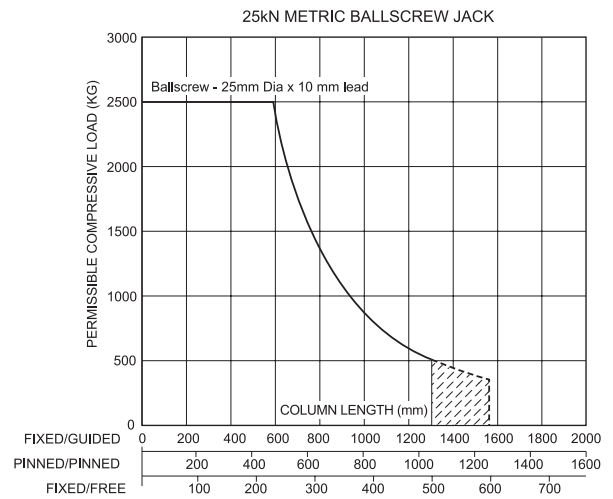
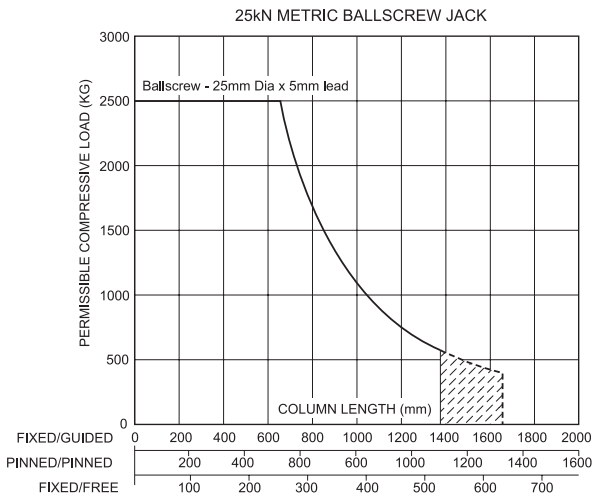
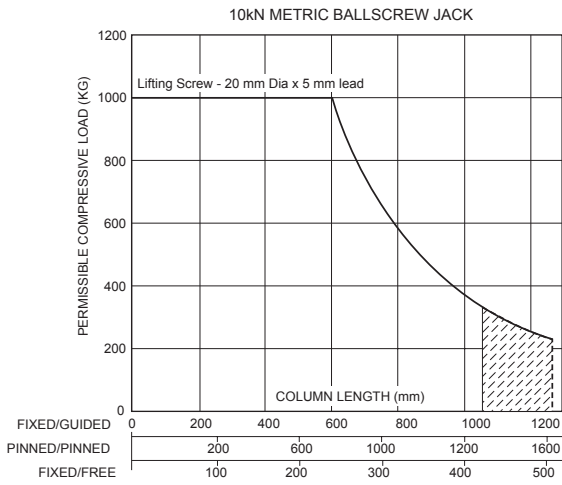

100kN METRIC BALLSCREW JACK

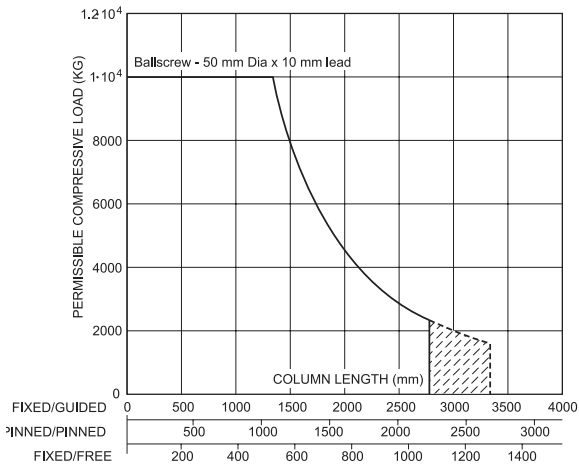

100kN METRIC BALLSCREW JACK

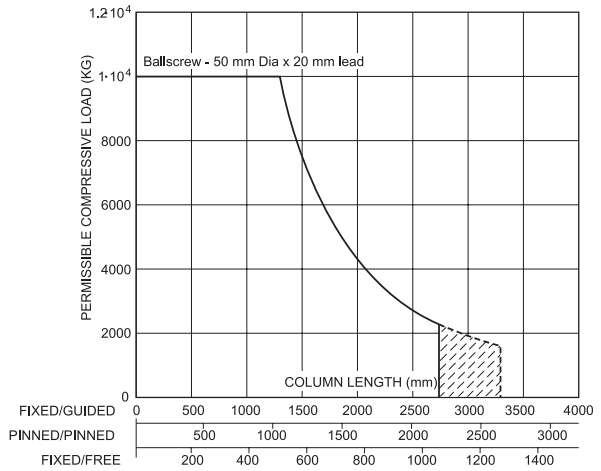

200kN METRIC BALLSCREW JACK

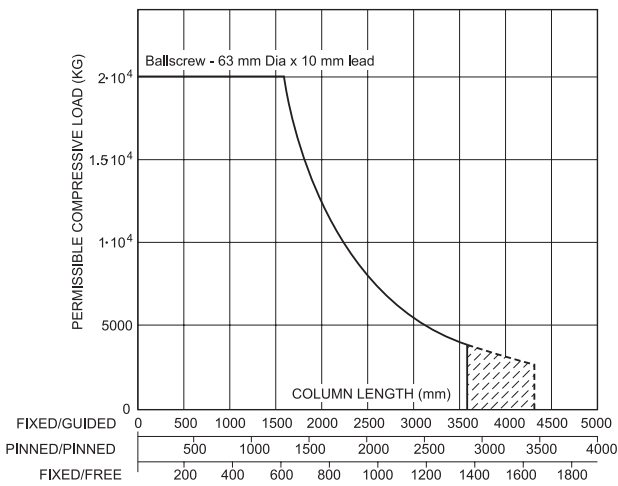

200kN METRIC BALLSCREW JACK

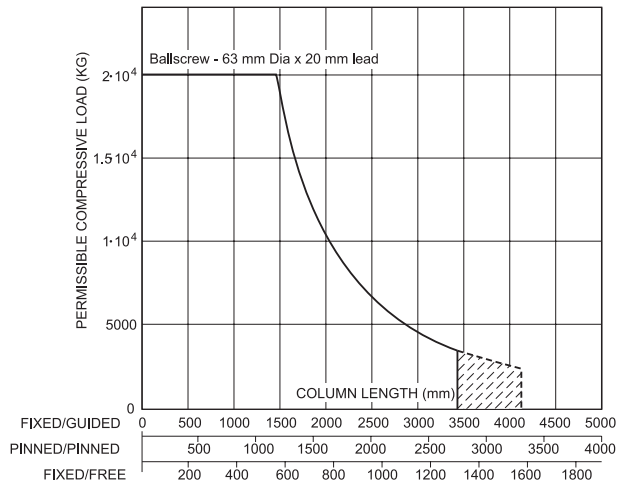

300kN METRIC BALLSCREW JACK

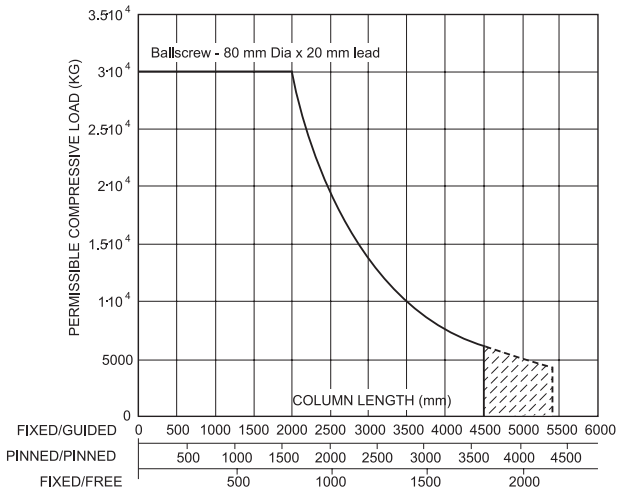

Critical Screw Speed Factors,  $F_{cs}$

Fixed/Free,  $F_{cs} = 0.15$

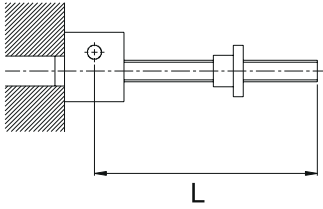

Fixed/Supported,  $F_{cs} = 0.7$

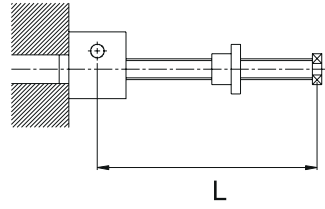

Fixed/Fixed,  $F_{cs} = 1$

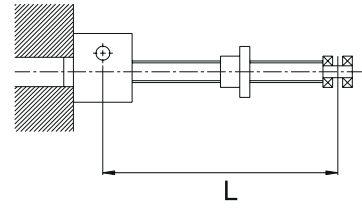

Machine Screw Critical Screw Speed (Shaft Whirling)

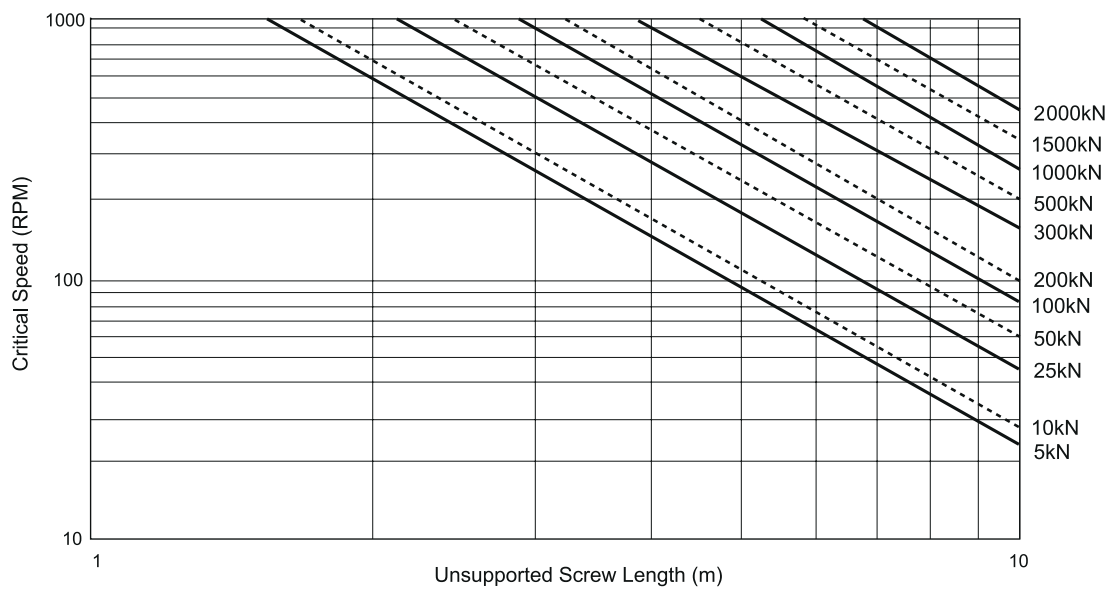

Based on both ends fixed and 80% of the critical speed.

Ball Screw Critical Screw Speed (Shaft Whirling)

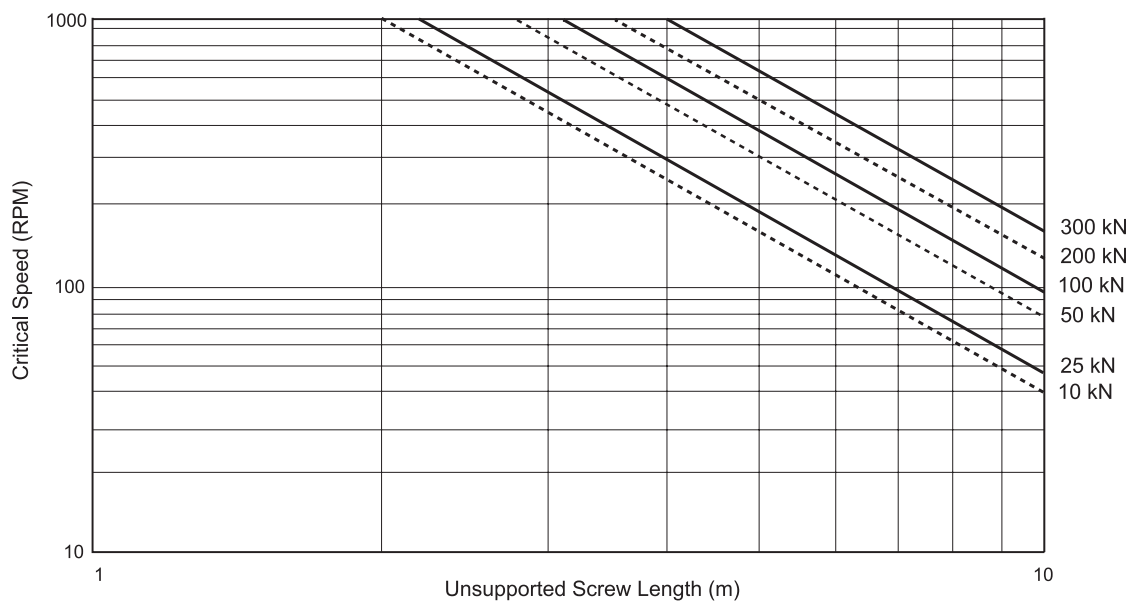

Based on both ends fixed and 80% of the critical speed.

The key torque (restraining torque) is caused by the tendency of the lifting screw to rotate. It is a function of the screw lead, screw efficiency and the load. It is not affected by the screw jack unit gear ratio.

#### Note

The values below are given at rated load. For a smaller load reduce the key torque in direct proportion.

#### Machine Screw Jacks

Capacity (kN)	Screw Diam (mm)	Lead (mm)	Key Torque (Nm)
5	16	0.003	8
5	16	0.006	11
10	20	0.005	22
10	20	0.010	30
25	30	0.006	76
25	30	0.012	102
50	40	0.009	210
50	40	0.018	290
100	55	0.012	575
100	55	0.024	780
200	65	0.012	1300
200	65	0.024	1705
300	95	0.016	2805
300	95	0.032	3610
500	120	0.016	5645
500	120	0.032	6975
1000	160	0.020	14890
1000	160	0.040	18220
1500	180	0.020	24610
2000	220	0.024	39995

#### Ball Screw Jacks

Capacity (kN)	Screw Diam (mm)	Lead (mm)	Key Torque (Nm)
10	20	0.005	9
10	-	-	-
25	25	0.005	23
25	25	0.01	43
50	40	0.01	88
50	40	0.02	167
100	50	0.01	181
100	50	0.02	340
200	63	0.01	370
200	63	0.02	690
300	80	0.02	1030
500		On Request	

## Maximum Jack Side Load Ratings with Full Jack Rated Load in Tension

### Machine Screw Jacks

Metric Machine Screw Jack									
Capacity (kN)	5	10	25	50	100	200	300	500	1000
Max. Side Load 300mm Offset (N)	100	150	540	1130	2900	3350	17500	37800	83400

### Ball Screw Jacks

Ball Screw Jack											
Capacity (kN)	10	25	25	50	50	100	100	200	200	300	500
Ball Screw Lead (mm)	5	5	10	10	20	10	20	10	20	20	*
Max. Side Load 300mm Offset (N)	105	195	195	980	980	1570	1570	2060	2060	4340	*

\*Consult Power Jacks.

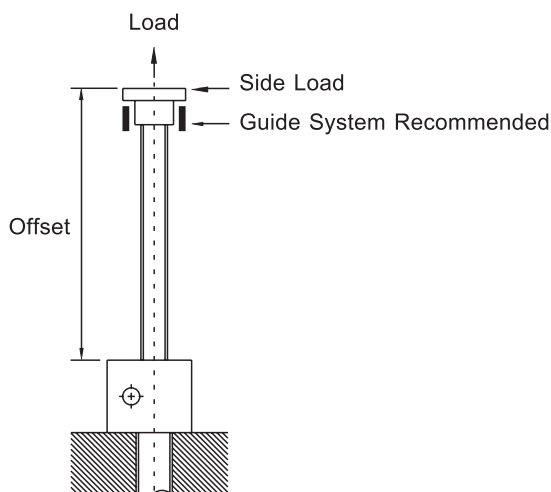

To calculate maximum side load for different raises for screw jacks in tension under full rated load use the following formula to modify the above tabulated values.

$$\text{Permissible Max. Side Load for Actual Offset} = \frac{\text{Max Side Load Rating Tabulated} \times \text{Stated Offset}}{\text{Actual Offset}}$$

#### Note

The correct units must be used

#### Important Notes

1. **These figures are for Screw Jacks in tension only.**
2. The figures given above are permissible side load ratings, however, we recommend that all side loads be carried by guides in your arrangement and not by the screw and nut.
3. Life of the lifting screw and nut will be adversely affected the more side load they see.
4. These figures are based on acceptable stresses in the lifting screw and not on lifting screw deflection.
5. For maximum side load ratings for screw jacks in compression consult Power Jacks Ltd.
6. For precise calculations for your application consult Power Jacks Ltd.

For applications where a screw jack is belt/chain driven, a calculation must be made to determine the radial force ( $F_R$ ) and compared to the allowable radial load exerted on the worm shaft, that must not exceed those tabulated below. The values below are maximum values for the screw jacks at rated load regardless of worm speed or load direction and the radial load applied midway along the key of the worm shaft. For all applications the sprocket, gear etc. Should be positioned as close as possible to the screw jack housing in order to reduce bearing loads and shaft stresses and to prolong life.

$$\text{Radial Force, } F_R = \frac{2000 \times T \times K}{D}$$

- Where
- $F_R$  = Radial Load (N)
  - $T$  = Torque applied to the screw jacks input shaft (Nm)
  - $K$  = Factor from table below
  - $D$  = PCD in mm of gear, sprocket

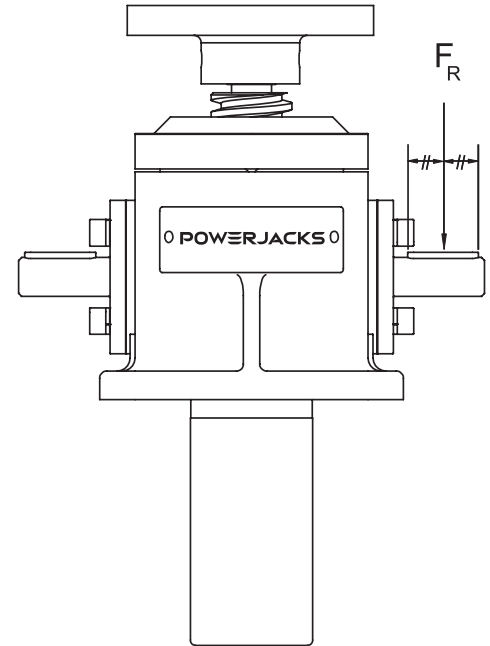

Transmission Element	Factor K
Chain sprocket	1
Gears (spur or helical pinion)	1.25
V-Belt pulley	1.5
Flatbelt pulley	2.0

Ball Screw Jack				
Capacity (kN)	25	50	100	200
Radial Load (N)	440	1100	1200	1600

Machine Screw Jack									
Capacity (kN)	5	10	25	50	100	200	300	500	1000
Radial Load (N)	180	325	380	740	1000	1600	2170	2190	2220

## Machine Screw Jacks

Component	Normal Backlash
Lifting Screw and Nut	0.12mm → 0.2mm (0.005" → 0.008")
Load Bearings	0.00mm → 0.03mm (0.000" → 0.001")
Total	0.12mm → 0.23mm (0.005" → 0.009")

### Note

1. The lifting screw backlash will increase during operation due to wear of threads in the nut
2. Axial play can be reduced by altering the load bearings preload to eliminate bearing play or by specifying a screw jack with the Anti-Backlash feature
3. For exact backlash ratings for an individual unit consult Power Jacks.

## Anti-Backlash Option

Machine screw jacks fitted with the anti-backlash feature can be adjusted for screw thread and bearing clearances to a minimum of 0.025 mm (0.001"). Some clearances must be maintained to keep torque requirements within reason and to provide adequate space for a lubrication film to form.

## Ball Screw Jacks

Component	Normal Backlash
Ball Track and Nut	0.05mm → 0.15mm (0.002" → 0.006")
Load Bearings	0.00mm → 0.03mm (0.000" → 0.003")
Total	0.05mm → 0.18mm (0.0002" → 0.007")

### Note

1. For exact backlash ratings for an individual unit consult Power Jacks.
2. Ball nuts can be supplied with zero backlash or with adjustable backlash via a special twin nut assembly (twin nut assembly for rotating screw units only). Consult Power Jacks for details.
3. Altering the load bearings preload to eliminate bearing play can reduce axial play.
4. There is no Anti-Backlash nut feature for the gear sets of these screw jacks.

## Pitch Deviation of Lifting Screw

Lifting Screw	Pitch Deviation
Machine Screw	0.05mm → 0.25mm per 300mm
Ball Screw	0.025mm → 0.050mm per 300mm (DIN Class 5.7)

### Note

1. Pitch deviation is cumulative and **NOT** detrimental to the operation of the Screw Jack
2. The Lifting screws are manufactured from material with a straightness tolerance of 0.2 mm per metre
3. Pitch deviation is related to the cutting machines tolerance and the material used.



## Machine Screw Jacks

Stroke (mm)	5kN	10kN	25kN	50kN	100kN	200kN	300kN	500kN	1000kN
100	0.7	0.6	0.8	1.0	1.0	0.4	0.4	0.7	0.7
200	1.3	1.1	1.4	1.7	1.7	0.7	0.6	1.0	1.0
300	1.9	1.5	1.9	2.3	2.3	0.9	0.8	1.3	1.3
400	2.5	2.0	2.5	2.9	2.9	1.2	1.0	1.7	1.6
500	3.1	2.4	3.1	3.6	3.6	1.4	1.2	2.0	1.9
600	3.7	2.8	3.6	4.2	4.2	1.6	1.4	2.3	2.2
700	4.3	3.3	4.2	4.8	4.8	1.9	1.6	2.6	2.4
800	4.8	3.7	4.8	5.5	5.5	2.1	1.8	2.9	2.7
900	5.4	4.2	5.3	6.1	6.1	2.4	1.9	3.2	3.0
1000	6.0	4.6	5.9	6.7	6.7	2.6	2.1	3.6	3.3

**Notes**

1. Values quoted above are the maximum expected lateral movement for the given raise and screw jack model.
2. Does not allow for possible deflection due to side loads.
3. Lateral movements are for information only. For best results we recommend guides where possible.
4. Lateral movements will be reduced if the screw jack is fitted with secondary guides.
5. The above movements apply to machine screw jack only and not ball screw jacks. Permitting lateral movement on the ball screw jack under load will exert side thrust on the ball screw and ball nut and will be detrimental to the ball screw and nut life. Ball screw applications should be guided to ensure a minimum of lateral movement.
6. Where lateral movement is critical consult Power Jacks for exact values for the application.



### How a Rotating Screw Jack Works

The rotation of the worm shaft causes the worm gear to rotate. For rotating screw jacks the lead screw is fixed to the worm gear and they rotate at the same speed. The lifting nut moves along the lead screw. As the worm gear turns, the friction forces on the screw thread act to turn the nut also. The greater the load on the screw jack unit, the greater the tendency of the nut to turn. If the nut turns with the screw, it will not raise the load. Therefore the nut needs to be fixed to a structure to prevent rotation. The restraining torque required for the structure, also known as the "lead screw key torque" can be found on the product performance tables in this catalogue or requested from Power Jacks.

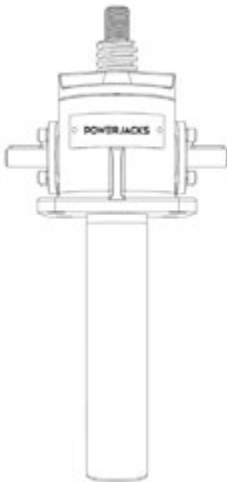

### How a Translating Screw Jack Works

The rotation of the worm shaft causes the worm gear to rotate. For translating screw jacks the worm gear is threaded to accommodate the lead screw thread. The lead screw translates through the gear. As the worm gear turns, the friction forces on the screw thread act to turn the screw also. The greater the load on the screw jack unit, the greater the tendency of the screw to turn. If the screw turns with the nut (worm gear), it will not raise the load. In those cases where a single unit is used, and where the load cannot be restrained from turning, it is necessary to use a screw jack with an anti-rotation mechanism (keyed screw jack). Lead screw key torque (refer to the product performance tables in this catalogue or request from Power Jacks) must be checked as excessively heavy unguided loads could break the Anti-rotation mechanism (key).

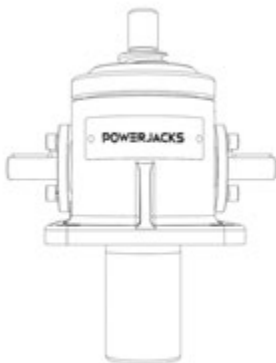

### Anti-Backlash Screw Jack – When To Use

For reduced axial backlash of the lead screw in the screw jack select a model with the "Anti-Backlash" mechanism. This is typically used when the load direction changes from tension to compression and minimal axial backlash is required. This design is only available for translating screw jacks. It can be combined with Anti-Rotation mechanism as well.

### Input Torque Required for a Screw Jack

The input torque for a single screw jack depends on the load, the worm gear ratio, type of screw (machine screw, ball screw or roller screw) and the pitch of the lead screw. Torque values are listed in the individual product specification charts based on capacity loads. For loads from 25% to 100% of screw jack model capacity, torque requirements are approximately proportional to the load.

#### **Note**

The input torque, as well as the efficiency and side load ratings, is the same for both translating screw and rotating screw jacks.

### Maximum Input Power & Speed for a Screw Jack

The input power to the screw jacks should not exceed the power rating shown in the specifications table. Maximum input speed in rpm (revolutions per minute) to a screw jacks worm shaft should not exceed 1800 rpm for C & E-Series screw jacks.

### Efficiency of a Screw Jack

Screw Jack model efficiencies are listed in the individual product specification charts.

### Expected Life of a Screw Jack

The life expectancy of a screw jacks lead screw, bearings, nut and worm gear set varies considerably due to the extent of lubrication, abrasive or chemical action, overloading, excessive heat, improper maintenance, etc. For detailed life calculations, consult Power Jacks.

### Screw Jack with Anti-Rotation (Keyed) Mechanism

This design is only available for translating screw jacks. If the structure/object connected to the lead screw is not prevented from rotating or the lead screw is not always in contact with the structure then a screw jack with an "Anti-Rotation" mechanism (keyed) should be used.

### Standard Screw Jacks - How To Prevent The Load from Rotating

For multiple screw jack systems, fix the lead screw end fittings (e.g. top plate or clevis) to the common member being lifted by all the units. For single screw jack applications, bolt the lead screw end fitting (e.g. top plate or clevis) to the load and ensure the load is guided to prevent rotation.

A guided load is always recommended to ensure that the screw jack does not receive any side load and so guidance can be scaled suitably for the load without altering the screw jack design unnecessarily. Note that an external guidance system can provide a higher restraining "key" torque than compared to an anti-rotation mechanism in a screw jack.

### Self-Locking of Screw Jacks

Screw Jacks with 24:1 or higher gear ratios are considered self-locking in most cases. Consult Power Jacks for a recommendation specific to your application.

All screw jacks with multi-start lifting screws are considered not to be self-locking.

All ball screw and roller screw jacks are considered not to be self-locking.

Screw Jacks considered not self-locking will require a brake or other holding device.

### Shock Loads on a Screw Jack

Shock loads should be eliminated or reduced to a minimum, if they cannot be avoided, the screw jack model selected should be rated at twice the required static load.

For severe shock load applications, the load bearings can be replaced with heat-treated steel thrust rings which is an option available from Power Jacks. Note this will increase the input torque by approximately 100%.

## Axial Backlash in a Screw Jack

### Backlash in Standard Machine Screw Jacks

Machine screw jacks have backlash due not only to normal manufacturing tolerances, but to the fact that there must be some clearances to prevent binding and galling when the screw jack unit is under load. Usually, the axial backlash is not a problem unless the load on the screw jack unit changes between compression and tension. If a problem does exist, a unit with the anti-backlash feature should be considered.

### Screw Jacks with the Anti-Backlash Device

The anti-backlash device reduces the axial backlash between the lead screw and nut assembly to a regulated minimum. As the backlash will increase as the lead screw thread on the gear wears the anti-backlash device can be adjusted to remove this normal condition.

### How the Anti-Backlash Device Works

When the screw (1) is under a compression load, the bottom of its thread surfaces are supported by the top thread surfaces of the worm gear (2) at point (A). The anti-backlash nut (3), being pinned to the worm gear and floating on these pins and being adjusted downward by the shell cap, forces its bottom thread surfaces against the upper thread surfaces of the lifting screw at point (B). Thus, backlash between worm gear threads is reduced to a regulated minimum.

When wear occurs in the worm gear threads and on the load carrying surfaces of the lifting screw thread, the load carrying thickness of the worm gear thread will be reduced. This wear will create a gap at point (B) and provide backlash equal to the wear on the threads.

Under compression load, the lifting screw will no longer be in contact with the lower thread surface of the anti-backlash nut. Under this condition, backlash will be present when a tension load is applied. The anti-backlash feature can be maintained simply by adjusting the shell cap until the desired amount of backlash is achieved.

To avoid binding and excessive wear do not adjust lifting screw backlash to less than 0.025mm (0.001"). This will reduce the calculated separation (C) between the anti-backlash nut and worm gear and will reduce the backlash between the worm gear threads and the lifting screw to the desired minimum value.

When separation (C) has been reduced to zero, wear has taken place. Replace the worm gear (2) at this point. This feature acts as a built in safety device which can be used to provide wear indication for critical applications.

### Column Strength of the Screw Jack

Column strength of a screw is determined by the relationship between the screw length and its diameter. For column strength charts consult product literature or Power Jacks.

### Side Loads on a Screw Jack

Screw jacks are designed primarily to move and position loads and any side loads (loads not acting axially on lead screw) should be avoided. The units will withstand some side loads, depending on the diameter of the lifting screw and the extended length of the lifting screw. Where side loads are present, the loads should be guided and the guides, rather than the screw jacks, should take the side loads - particularly when long raises are involved. Even a small side load can exert great force on the housings and bearings and increase the operating torque and reduce the life expectancy.

### Allowable Duty Cycle of Screw Jack

Because of the efficiency of conventional worm gear screw jacks, the duty cycle is intermittent at rated load. At reduced loading, the duty cycle may be increased. Ball screw jacks are more efficient than machine screw jacks and so can provide a higher duty cycle. In addition Power Jacks have special designs for high duty cycle screw jacks. For detailed analysis consult Power Jacks Ltd.

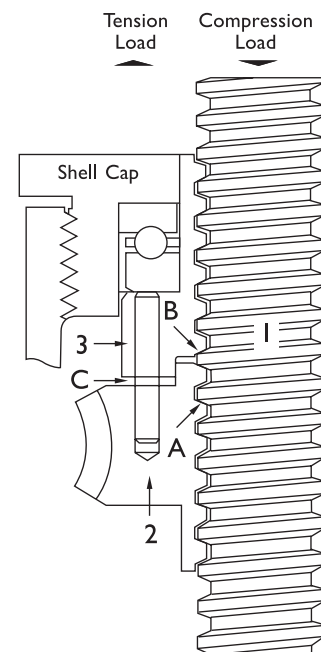

### Maximum Operating Temperatures For E-Series Screw Jack

Normal operation at ambient temperatures of up to 90°C. Operations above 90°C will require special lubricants. For temperatures above 90°C, the life of even special lubricants is limited. Therefore consult Power Jacks on your application. For temperatures above 90°C, advise Power Jacks of full particulars of the duration of such temperatures. Power Jacks suggest that a lubricant manufacturer be consulted for type of grease and lubrication schedule. As a general rule, the screw jack unit should be shielded to keep ambient temperatures to 90°C or less.

### Minimum Temperature For E-Series Screw Jacks

With the standard lubricant and materials of construction, the screw jacks are suitable for use at sustained temperatures of -20°C. Below -20°C, low temperature lubricant should be used and no shock loads are present. Power Jacks application engineers must be consulted in these instances for a recommendation. Screw Jacks with standard material of construction and lubrication may be safely stored at temperatures as low as -55°C.

### Thermal / Heat Build-Up in a Screw Jack as it is operated

The duty cycle, the length of the screw, the magnitude of the load, and the efficiency of the screw jack all have a direct influence on the amount of heat generated within the screw jack. Long lifts can cause serious overheating. Note that Power Jacks have special designs with higher thermal capacities than conventional worm gear screw jacks (consult Power Jacks for more details).

### Screw Jacks to Pivot a Load

A screw jack can be built to pivot a load by two methods:

1. Double Clevis Screw Jack

The screw jack can be furnished with a clevis at both ends (commonly referred to as a double clevis screw jack). The bottom clevis is welded to the bottom end of an extra strong cover pipe, which is fitted to the base of the screw jack. This cover pipe still performs its primary function of encasing the lifting screw in its retracted portion. The clevis ends can be replaced with other pivot options such as Fork End or Rod End.

2. Clevis - Trunnion Mounting

The screw jack is fitted with the pivot end fitting (e.g. Clevis, Fork or Rod End) on the lead screw and a trunnion mount adapter is bolted to the screw jacks base plate.

The design of the structure in which these types of screw jacks are to be used must be constructed so that screw jack can pivot at both ends. Use only direct compression or tension loads, thereby eliminating side load conditions.

### Corrosion Resistant Properties

Screw Jacks can be supplied with alternative materials and/or paint specifications for high corrosive areas. These options include stainless steel, chrome plating, electro-nickel plating, epoxy paint, etc. Check the unit specification is suitable before installation.

### Using Screw Jacks within a Rigid Structure or Press

Power Jacks recommend that the screw jack selected has a greater capacity than the rated capacity of the press or of the load capacity of the structure. We also recommend that a torque clutch or similar device be used to prevent overloading of the screw jack unit. Unless these precautions are taken, it is possible to overload the screw jack without realising it.

### Screw Jack Drift after Drive Motor is Switched Off

The screw jack will drift after the motor drive is switched off unless a brake of sufficient capacity is used to prevent it. The amount of drift will depend upon the load on the screw jack and the inertia of the rotor in the motor.

For machine screw jacks with no load, the amount of drift will depend upon the size and speed of the motor. For example, a 1500 RPM input directly connected to a screw jack without a load will give on average 35mm to 60mm of drift; a 1000 RPM input will give about 1/2 as much drift. Note that the drift varies as the square of the velocity (RPM). The drift of the screw jacks screw can be controlled by using a magnetic brake on the motor. Variations of drift will also be seen if the motor drives the screw jack via a reduction gearbox.

### Screw Jacks Operation where Vibration is Present

Screw Jacks will operate in areas with vibration, however the vibration may cause the lead screw to “creep” or “inch” under load. For applications involving slight vibration, select the higher of the worm gear ratios. If considerable vibration is present, use a motor equipped with a magnetic brake, which will prevent the screw jack from creep and/or back-driving.

### Use of Screw Jacks Fitted With Emergency Stop Disc

To prevent over travel of the lead screw, a stop disc or nut can be fitted to a screw jack that is hand operated. It should not be used as a full power stop.

### Use of Screw Jacks Fitted With Emergency Stop Nut

For motor driven units, it is possible for the full capacity of the screw jack or even a greater force (depending on the power of the motor) to be applied against the stop. These stops are called “full power stop nuts”. They must only be used as an emergency device and if such a condition occurs, an assessment made to discover why it happened in order to carry out preventative action. If the full power stop nut is used at full load in an emergency it might be driven into the unit jamming so tightly that it must be disassembled in order to free it.

It is recommended that external stops are fitted where possible, however they must only be used as a last resort (Note - limit switches are one possible solution to constrain screw jack movement safely - consult Power Jacks for system advice). Under ideal conditions where a slip clutch or torque limiting device is used, a stop pin or stop nut may be used - but Power Jacks should be consulted.

### Screw Jack System Arrangements

Perhaps the greatest single advantage of Power Jacks screw jacks is that they can be linked together mechanically, to lift, lower, move or position in unison. Typical mechanical system arrangements link 2, 4, 6 or 8 screw jacks together and are driven by one motor. As an alternative, screw jacks can be individually driven by electric motors and with suitable feedback devices, such as encoders, be synchronised electronically by a control system.

### Connecting Screw Jacks in Series

The number of screw jacks that can be connected in series is limited by input torque requirements on the first worm shaft in the line. For the C & E-Series the torque on the worm shaft of the first screw jack should not exceed 300% of its rated full load torque (this does not include the 200kN screw jacks which are rated at 150%).

### Efficiency of a Multiple Screw Jack System

In addition to individual device efficiencies, the efficiency of the screw jack arrangement must be taken into consideration. The arrangement efficiency allows for misalignment due to slight deformation of the structure under load, for the losses in couplings, bearings, and for a normal amount of misalignment in positioning the screw jacks and gearboxes. For efficiency values consult Power Jacks product literature or engineers.

Number of Screw Jacks in System	2	3	4	6-8
Jacking System Efficiency	0.95	0.90	0.85	0.80

### Screw Jack Fitted with 3rd Party Accessories

If your screw jack is fitted with a device not manufactured by Power Jacks then please consult the provided manual for this device.

## Installation and Maintenance Tips

The following installation and maintenance tips are for the C & E-Series, Metric machine screw and ball screw jacks models. General care should be taken to ensure that equipment is sufficient to handle the load.

1. The structure on which the screw jack unit is mounted should have ample strength to carry the maximum load, and be rigid enough to prevent undue deflection or distortion of the screw jack unit supporting members.
2. It is essential that the screw jack be carefully aligned during installation so that the lifting screws are vertically true and the connecting shafts are exactly in line with the worm shafts. After the screw jack, shafting, and gear boxes are coupled together, it should be possible to turn the main drive shaft by hand. If there are no signs of binding or misalignment, the jacking system is then ready for normal operation.
3. The screw jack should have a greater stroke than is needed in the screw jack installation. If it is necessary to operate the screw jack at the extreme limits of travel, it should be done with caution.

**CAUTION: Do not allow screw travel below catalogue closed height of the screw jack or serious damage to internal mechanism may result. Refer to table specifications for closed height of respective units.**

4. The input power should not exceed the power rating shown in the specification table. Maximum RPM should not exceed 1800.
5. The lifting screw should not be permitted to accumulate dust and grit on the threads. If possible, lifting screws should be returned to closed position when not in use.
6. The ball screws in the ball screw jacks should be checked periodically for excessive backlash and spalling of raceways. A periodic check of backlash of the lifting screw thread is recommended to check wear of the worm gear internal threads on the machine screw jack models. Backlash in excess of 50% of the thread thickness indicates the need to replace the worm gear.
7. Unless otherwise specified, screw jacks are shipped packed with grease which should be sufficient for one month of normal operation. For normal operation, the screw jacks should be lubricated about once a month, using one of the following extreme pressure greases or their equivalent:

Shell	Gadus S2V220AC2 (Alvania WR2)
BP	Energrease LC2
Castrol	Spheerol EPL2
Mobil	Mobilux EP2

For severe conditions, the screw jacks should be lubricated more frequently, using one of the above greases (daily to weekly depending on conditions). If duty is heavy, an automatic lubrication system is strongly recommended. If ambient temperatures exceed 90°C (194°F) consult Power Jacks.

8. On ball screw jack applications, periodically lubricate the exposed ball screw grooves with a cloth dampened with a good grade 10W30 oil for most applications. An instrument grade oil should be used in dirty and heavy duty environments, and bearing grease for environments at extremely high temperatures. Extreme temperature and other environmental conditions should be referred to Power Jacks for recommended lubricating procedures.

**CAUTION: Where ball screws are not protected from airborne dirt, dust, etc., bellows boots should be used. Inspect frequently at regular intervals to be certain a lubricating film is present. Ball screws should never be run dry.**

9. Due to the high efficiency of the ball screw jack design, a brake must be used in conjunction with motor selected to position the screw jack.



## Useful Formulae for Screw Jack Calculations

---

### Lifting Screw Lead

Lifting Screw lead (mm) = Screw Pitch (mm) \*Number of Starts on Lifting Screw

### Calculation of the Linear Speed

When the worm shaft speed is known, the linear speed can be determined with this formula:

$$\text{Linear Speed (mm/min)} = \frac{\text{RPM of Worm Shaft} \times \text{Lifting Screw Lead (mm)}}{\text{Gear Ratio}}$$

or alternatively

$$\text{Linear Speed (mm/min)} = \frac{\text{RPM of Worm Shaft}}{\text{Turns of Worm for 1mm Travel}}$$

### Calculation of Screw Jack Input Torque

$$\text{Input Torque (Nm)} = \frac{\text{Load (kN)} \times \text{Lifting Screw Lead (mm)}}{2 \times \pi \times \text{Efficiency} \times \text{Gear Ratio}}$$

or alternatively

$$\text{Input Torque (Nm)} = \frac{\text{Input Power (kW)} \times 9550}{\text{Input Speed (rpm)}}$$

### Calculation of Screw Jack Input Power

$$\text{Input Power (kW)} = \frac{\text{Load (kN)} \times \text{Lifting Screw Lead (mm)} \times \text{Input Speed (rpm)}}{60000 \times \text{Efficiency} \times \text{Gear Ratio}}$$

or alternatively

$$\text{Input Power (kW)} = \frac{\text{Load (kN)} \times \text{Linear Speed (mm/min)}}{60000 \times \text{Efficiency}}$$

## Useful Formulae for Screw Jack Calculations

Power	Metric	Imperial
Lifting Motion	$P = \frac{m \times g \times v}{\eta \times 1000}$	$P = \frac{w \times v}{\eta \times 33000}$
Linear Motion	$P = \frac{F_R \times v}{1000}$	$P = \frac{F_R \times v}{33000}$
	$F_R = \mu \times m \times g$	$F_R = \mu \times w$
Rotary Motion	$P = \frac{T \times n}{9550}$	$P = \frac{T \times n}{63000}$
<b>Torque</b>		
	$T = F_R \times r$	$T = T \times r$
Linear Motion	$T = \frac{P \times 9550}{n}$	$T = \frac{P \times 6300}{n}$

Symbol	Quantity	Metric Units	Imperial Units
P	Power	kW	HP
T	Torque	Nm	lbf.in
$F_R$	Resistance due to Friction	N	lbf
m	Mass	kg	-
W	Weight	-	lb
g	Gravitational Acceleration	9.81 ms <sup>-2</sup>	32.185 ft <sup>-2</sup>
v	Velocity	ms <sup>-1</sup>	ft/min
$\eta$	Efficiency	decimals	decimals
$\mu$	Coefficient of Friction	decimals	decimals
n	Rotational Speed	rpm	rpm
r	Radius	m	in

## Useful Formulae for Screw Jack Calculations

**Moment of Inertia****Metric****Imperial**

$$\text{Solid Cylinder} \quad J = \frac{1}{2} \times m \times r_{od}^2$$

$$WK^2 = \frac{1}{2} \times W \times r_{od}^2$$

$$\text{Hollow Cylinder} \quad J = \frac{1}{32} \times \varpi \times \rho \times d_{od}^4$$

$$WK^2 = \frac{\varpi}{32} \times r \times l \times d_{od}^4$$

$$J = 0.098 \times \rho \times l \times d_{od}^4$$

$$WK^2 = 0.1 \times \rho \times l \times d_{od}^4$$

$$\text{Hollow Cylinder} \quad J = \frac{1}{2} \times m \times (r_{od}^2 - r_{id}^2)$$

$$WK^2 = \frac{1}{2} \times W \times (r_{od}^2 - r_{id}^2)$$

$$J = \frac{1}{32} \times \varpi \times \rho \times l \times (d_{od}^4 - d_{id}^4)$$

$$WK^2 = \frac{\varpi}{32} \times \rho \times l \times (d_{od}^4 - d_{id}^4)$$

$$J = 0.098 \times \rho \times l \times (d_{od}^4 - d_{id}^4)$$

$$WK^2 = 0.1 \times \rho \times l \times (d_{od}^4 - d_{id}^4)$$

**Acceleration or Braking Time**

$$T_{acc} = \frac{J \times n}{9.55 \times T_{acc}}$$

$$T_{acc} = \frac{WK^2 \times n}{308 \times T_{acc}}$$

Symbol	Quantity	Metric Units	Imperial Units
J	Moment of Inertia (metric)	kgm <sup>2</sup>	-
WK <sup>2</sup>	Moment of Inertia (imperial)	-	lb.ft <sup>2</sup>
T <sub>acc</sub>	Torque due to Acceleration or Braking	Nm	lbf.ft
m	Mass	kg	-
W	Weight	m	lb
g	Outer Radius	m	ft
v	Internal Radius	m	ft
η	Outer Diameter	m	ft
μ	Internal Diameter	m	ft
n	Density	kg/m <sup>3</sup>	kg/m <sup>3</sup>
r	Time for Acceleration or Braking	s	s
r	Rotational Speed	rpm	rpm

Bevel Gearbox Range-C

10

Range-C Bevel Gearboxes

ULTRA COMPACT &  
VERSATILE SPIRAL BEVEL  
GEARBOXES

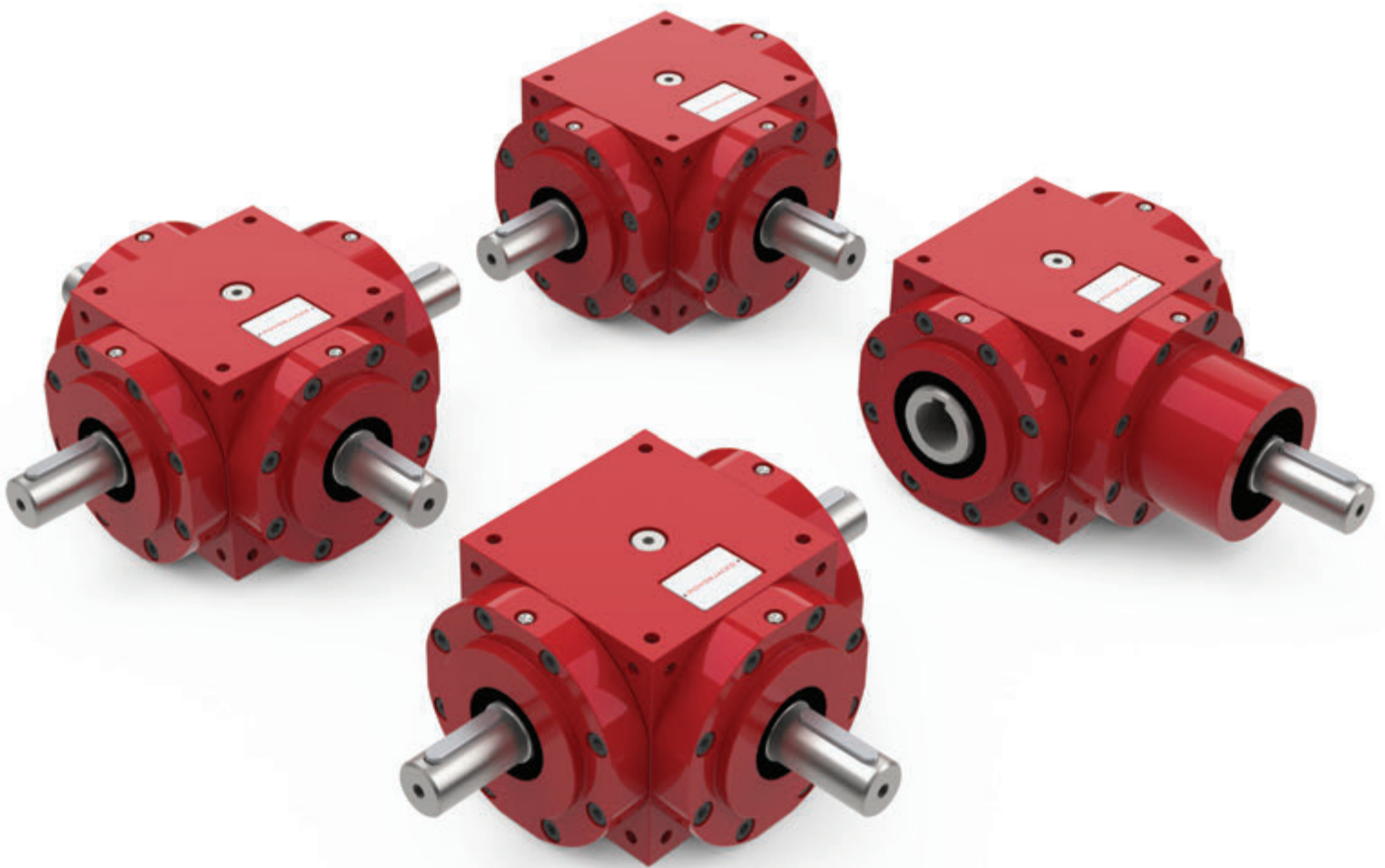

## Introducing the Range-C bevel gearbox range from Power Jacks, a compact and versatile design in a cubic housing.

Created by a team of experienced design engineers, the focus was to provide our customers with a compact bevel gearbox in a "cubic" housing that offers versatility in design. In addition to this, we wanted to design a bevel gearbox that had the perfect combination of excellent performance, a long lasting service life, durability and the flexibility to be engineered for the most demanding applications.

Perfect for industrial applications or the extreme such as subsea, defence or nuclear.

### Standard Gearbox

- 6 Gearbox Sizes  
35, 37, 38, 39, 40, 42\* Series  
\*42-Series in Range-N design only
- 16 Gearbox Configurations
- Gear Ratios:  
1:1, 1.5:1, 2:1, 3:1 and 4:1\*  
\*No 4:1 on 35-Series
- Special gear ratios available on request  
e.g. 1.25:1
- Power Ratings: 0.1 - 226 kW
- Torque Ratings: 15 Nm - 7000Nm
- Mounting Points on Every Gearbox Side (35 - 40 Series)

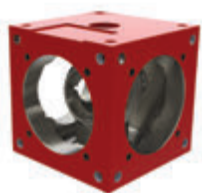

### Gearbox Housing

A rugged Cubic Compact design made from a highly durable SG Iron. This provides a strong housing that firmly and accurately holds the gear set in a reservoir of quality lubricant suited to the most industrial demands.

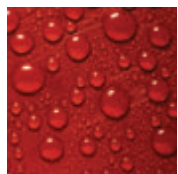

### Corrosion Protection

To suit all economic needs.

- Standard Industrial Paint Finish
- Arduous Environment Paint Finish
- Customer Specified Paint
- Plated Finish
- Stainless Steel

### Reliable Spiral Bevel Gear

With a proven design already used in millions of gearboxes, the Precision Spiral Bevel Gears with accurate gear mesh delivers high torque with smooth and quiet transmission.

### Superior Gear and Shaft Support

For gear ratios 1:1 and 1.5:1 where each gear has a bearing support on both sides. This gives optimum gear support and minimises bearing hub sizes for non-through shaft configurations.

### Shaft Configurations

- 2, 3 or 4-way
- Solid or hollow shaft
- Special configurations available
- Motor Adapter to bolt an IEC motor directly to the gearbox input
- Service life of 10,000 hours for all gearbox sizes
- Input Speed up to 3000 rpm maximum
- Breather / vents available for high speed designs



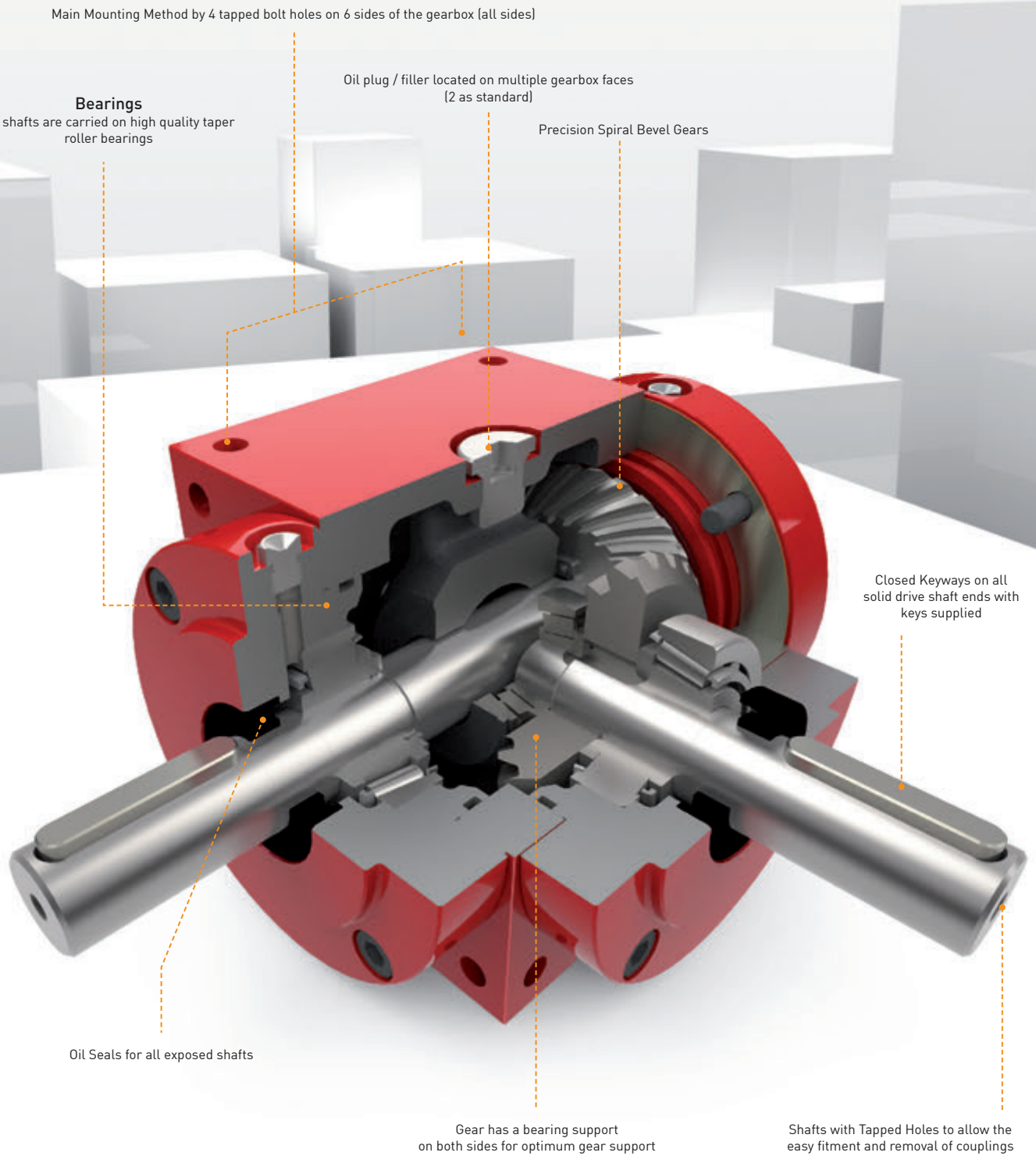



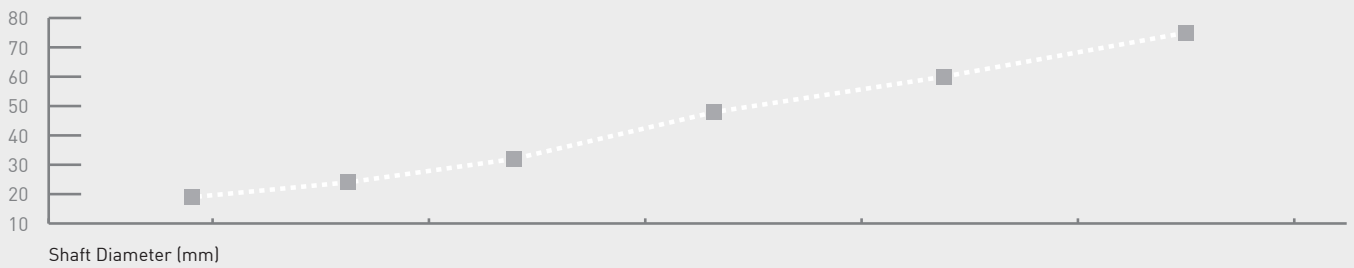
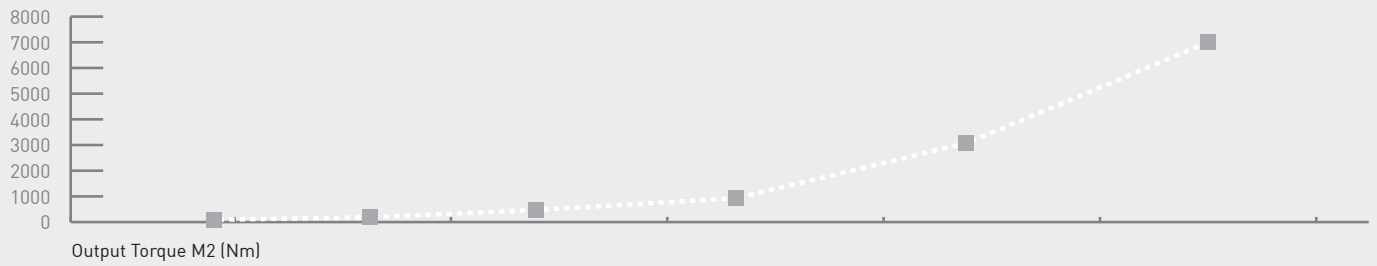
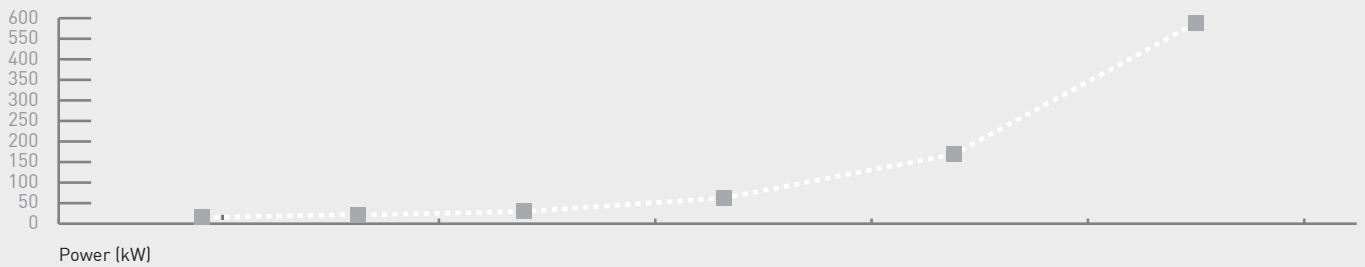
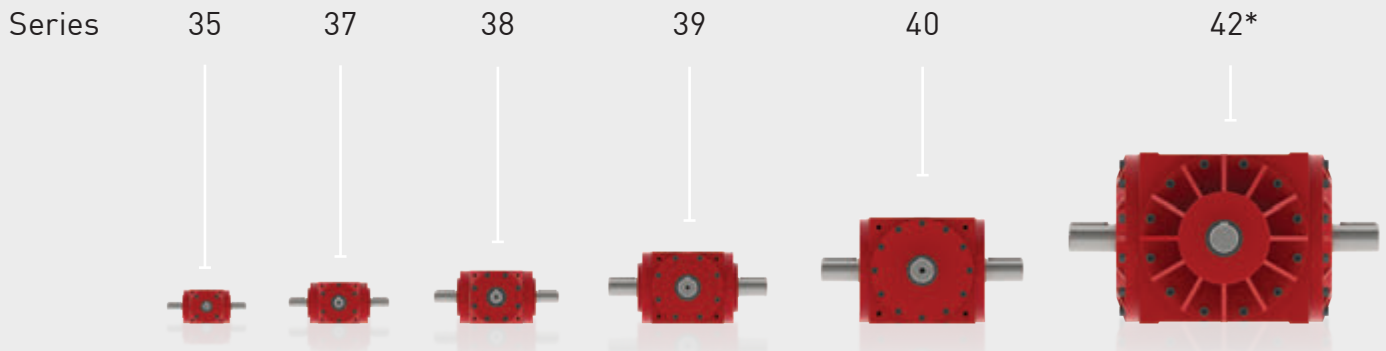

Based on Ratio 1:1, 3way solid shaft, Gear Unit Size  
 \*42 Series is Range-N design

Example

**C380S30-10M06-0000-0000-000000** C-Range, 38 Series, Standard, Solid Shaft, 4-Way, Standard Gear Configuration, 1:1 Gear Ratio, Metric Shaft (mm) - Spiral Bevel, Standard Material Shafts lubrication and paint.

1	2	3	4	5	6	7	8	9	10	11	12	13	14	15	16	17	18	19	20	21	22	23	24	25	26	27	28	29	30
C	3	8	0	S	3	0	-	1	0	M	0	6	-	0	0	1	0	-	0	0	0	0	0	-	0	0	0	0	0

**1 GROUP-1 - Bevel Gearbox Definition**

**2 GROUP-2 - Bevel Gearbox Features**

**3 GROUP-3 - Accessories**

**1 GROUP-1 - Bevel Gearbox Definition**

1-Bevel Gearbox Range	
C	Compact Cubic, Versatile Design with mounting bolt holes on every gearbox side
N	Ultra Compact, Versatile Design

2-3 - Gearbox Series	35	37	38	39	40	42
----------------------	----	----	----	----	----	----

4-Gearbox Type	
0	Standard
V	Vertical Shaft

5-Shaft Type	
S	Solid Shaft
H	Hollow Shaft

6-Shaft Number	
2	2-Way
3	3-Way
4	4-Way

7-Shaft Configuration	
0	Standard Gear Configuration
R	Reverse Gear Configuration

**8 - Character Space**

9-10 - Shaft Number	
10	1:1 Gear Ratio
15	1.5:1 Gear Ratio
20	2:1 Gear Ratio
30	3:1 Gear Ratio
40	4: 1 Gear Ratio

11-Gear & Shaft Design	
M	Metric Shaft (mm) - Spiral Bevel

12-13 - Design Revision	
XX	Internal Numbering System Only #1

**14 - Character Space**

## 2 GROUP-2 - Bevel Gearbox Features

15-Gearbox Housing Material	
0	Standard Material (SG Iron)
A	Aluminium
N	Nickel Plated SG Iron Housing
S	Stainless Steel Housing

16-Drive Shaft Design	
0	Standard Material
1	Reinforced Through Shaft for Higher Torque Transmission #10
C	Chrome Plated Drive Shafts
D	Chrome Plated & Reinforced for Through Shaft #10
N	Nickel Plated Drive Shafts
M	Nickel Plated & Reinforced for Through Shaft #10
S	Stainless Steel Drive Shafts
T	Stainless Steel & Reinforced for Through Shaft #10

17-Mounting	
0	Standard Range-N - 4 Tapped Holes - Side 5 & 6
1	Standard Range-C - ALL Sides Tapped Holes
5	4 Tapped Holes Side 5 Only
6	4 Tapped Holes Side 6 Only
A	Base Flange - Bolt-On - Side 5
B	Base Flange - Bolt-On - Side 6

18-Environment & Temperature Rating #8	
0	Standard
1	High Temperature
2	Low Temperature
N	Radiation Resistant
M	Radiation Resistant & Low Temperature
P	Radiation Resistant & High Temperature
R	Chemical Resistant
S	Chemical Resistant & Low Temperature
T	Chemical Resistant & High Temperature

## 19 - Character Space

20-Drive Shaft Keys - Side-1 (input)	
0	Standard (Closed Keyway) - also select if motor adapter
1	Open Keyway
2	Keyless #4

21-Drive Shaft Keys - Side-2	
0	Standard (Closed Keyway)
1	Open Keyway #2
2	Keyless #4

22-Drive Shaft Keys - Side-3	
0	Standard (Closed Keyway) - also select if hollow shaft #3
1	Open Keyway #2
2	Keyless #4

23-Drive Shaft Keys - Side-4	
0	Standard (Closed Keyway) - also select if hollow shaft #3
1	Open Keyway #2
2	Keyless #4

## 24 - Character Space

### 3 GROUP-3 - Accessories

25-Drive Type	
0	Standard (normal shafts, no extra features)
A	Motor Adapter, Input, B14
B	Motor Adapter, Input, B5
H	Hand Wheel - Side 1 (Input)
J	Hand Wheel - Side 2
K	Hand Wheel - Side 3
L	Hand Wheel - Side 4

26-Motor Frame Size	
0	Not Applicable
A	63
B	71
C	80
D	90
E	100
F	112
G	132
H	160
I	180
J	200

27-Drive Shaft Protective Cover	
0	None - Standard
1	Cover- Side 1 (Input)
2	Cover - Side 2
3	Cover - Side 3
4	Cover - Side 4
A	Cover - Side 2 & 3
B	Cover - Side 2 & 4
C	Cover - Side 3 & 4
R	Rotation Indicator (Visual) - Side 1
S	Rotation Indicator (Visual) - Side 2
T	Rotation Indicator (Visual) - Side 3
U	Rotation Indicator (Visual) - Side 4

28-Breather (Vent)	
0	None (Standard) <sup>#5</sup>
1	Breather fitted Side-1 (Input)
2	Breather fitted Side-2
3	Breather fitted Side-3
4	Breather fitted Side-4
5	Breather fitted Side-5
6	Breather fitted Side-6 <sup>#6</sup>
A	Breather 90deg Type fitted Side-1 (Input)
B	Breather 90deg Type fitted Side-2 <sup>#7</sup>
C	Breather 90deg Type fitted Side-3
D	Breather 90deg Type fitted Side-4
E	Breather 90deg Type fitted Side-5
F	Breather 90deg Type fitted Side-6

29-Lubricant <sup>#9</sup>	
0	Standard Oil (input speed >250 rpm)
1	Standard Grease (input speed < 250rpm)
2	No Lubricant
A	Food Grade Oil
B	Food Grade Grease
C	Nuclear Grade Oil
D	Nuclear Grade Grease
E	Biodegradable Oil
F	Biodegradable Grease

30-Paint	
0	Standard Paint (Red)
1	Standard Primer (Grey) Only
2	Standard Epoxy Paint (Red)
3	Subsea Paint (Yellow)
4	No Paint

**Notes:**

- #1 Internal design revision number leave as XX and Power Jacks will update at time of order.
- #2 Not applicable to hollow shaft gearboxes.
- #3 Select if hollow shaft gearboxes with standard shaft designs on hollow shaft.
- #4 Keyless shaft design, typically for servo couplings.
- #5 Suitable for horizontal gearbox mounting, running within allowable speed limits for lubrication.
- #6 Common side for breather on horizontally mounted gearbox (on side 5) with oil lubrication
- #7 Common side for 90deg breather on 2-way or 3-way horizontally mounted gearbox (on side 5) with oil lubrication
- #8 The environment and temperature range specified here dictates the seal type and temperature rating of the gearbox, hence temperature rating / type of lubricant as well.
- #9 Type / Grade of lubricant defined by character 29 and 18
- #10 The gearboxes "Through Shaft" is reinforced to transmit higher torque. It does not increase the torque transmitted through the gear set.

When selecting a gearbox, there are a number of factors which can influence the final size of unit selected. The information contained in the selections gearbox characteristics and Technical data provide details of these factors for use in the selection process.

The following Selection Procedure provides a step-by-step guide to gearbox selection for those not fully familiar with the procedures. An example has been used in the selection procedure to assist in following through the procedure.

Specified information	Example Information
1. Gearbox Input Speed (rpm)	1000
2. Gearbox Output Speed (rpm)	500
3. Gearbox Configuration (page 213)	2 Way
4. Required Output Torque (Nm)	150
5. Operating Hours per Day (HRS)	10
6. Input Power Source (page 210)	Electric Motor
7. Gearbox Application (page 210)	Stacking Machine
8. Number of Starts per Hour (page 210)	8
9. Transmission Methods (page 210)	Clutch
10. Duty Cycle per Hour [% Running time]	45/60 = 75%
11. Operating Ambient Temperature °C (page 211)	20

Selection of Design Factors	Example Design Factors
<b>Step 1 - Shock Load Factor (<math>f_1</math>)</b> Using the Specified Information in Points 5, 6 and 7 above, select the Shock Load Factor from the Page 210.	1.25
<b>Step 2 - Starting Frequency Factor (<math>f_2</math>)</b> Using the Specified Information in Point 8 above, select the Starting Frequency Factor from the page 210.	1.00
<b>Step 3 - Transmission Load Factor (<math>f_3</math>)</b> Using the Specified Information in Point 9 above, select the Transmission Load Factor from the Page 210.	1.00
<b>Step 4 - Thermal Limit - Duty Cycle - Factor (<math>f_4</math>)</b> Using the Specified Information in Point 10 above, select the Thermal Limit - Duty Cycle - Factor from the Page 210.	1.25
<b>Step 5 - Thermal Limit- Ambient Temperature - Factor (<math>f_5</math>)</b> Using the Specified Information in Point 11 above, select the Thermal Limit - Ambient Temperature -Factor from the Page 211.	1.00



A gearbox is required for an Input Speed of 1000 rpm, an Output Speed of 500 rpm, an Output Torque of 150Nm and one Output Shaft. The Drive is by electric motor through a clutch mechanism and the gearbox is on the main drive of a heavy duty stacking machine. The machine operates for 10 hours per day, starts 8 times per hour and operates for 45 minutes in every hour, the other 15 minutes being taken up in loading the machine. The ambient temperature of the premises is 20°C.

Calculated data

Example Data

<p><b>Step 6</b> - Calculate the Gear Ratio                  Input Speed ÷ Output Speed                  Note: If the gear ratio does not correspond to one of the STANDARD ratios contained in this technical manual, one of the speeds, normally the output speed, must be changed to bring the ratio to standard. Non-standard ratios can be supplied, if required, but such special selections must be referred to Power Jacks.</p>	<p>1000/500 = 2                  Therefore 2:1 Reduction</p>
<p><b>Step 7</b> - Calculate the Corrected Output Torque                  Required Output Torque x <math>f_1</math> x <math>f_2</math> x <math>f_3</math>                  Note: Where there is more than one output shaft, the Required Output Torque for the gearbox is the summation of the individual Output Torques from the output shafts.</p>	<p>150 x 1.25 x 1.00 x 1.00 x = 187.5 Nm</p>
<p><b>Step 8</b> - Calculate the Corrected Output Power                  Required Output Torque x Output Speed / 9550</p>	<p>(187.5 x 500) / 9550 = 9.82 kW</p>
<p><b>Step 9</b> - Calculate the Required Input Power = Output Power / Efficiency (Gearbox efficiency is between 95% and 98% after initial running in).</p>	<p>9.82 / 0.98 = 10.02 kW</p>

Gearbox Selection

Example Gearbox Selection

<p><b>Step 10</b> - From the GEARBOX TORQUE x POWER RATING TABLE (page 209), select the gearbox with the closest adequate rated power.</p>	<p>From the Selection Table on page 209, for Input Power 10.02 kW, gear ratio 2:1 and Input Speed 1000 rpm, select Series 39.</p>
<p><b>Step 11</b> - When selecting a gearbox, the Thermal Capacity of the gearbox chosen must be considered. For the Limiting Thermal Capacity (page 211), expressed as a Power Rating. For the selected gearbox, calculate the Thermal Capacity = Limiting Thermal Capacity x <math>f_4</math> x <math>f_5</math>.                  The Calculated Input Power must not exceed this Calculated Thermal Capacity. A larger gearbox must be selected if the Calculated Input Power is higher and a check run on the other parameters.</p>	<p>From the table in page 211, Limiting Thermal Capacity for Series 39 is 49kW.                   Calculate the gearbox,                  Thermal Capacity = 49 x 1.25 x 1.00 = 61.25 kW                   The Input Power is within this limit. Selected gearbox is OK.</p>
<p><b>Step 12</b> - As a final check on the capacity of the chosen gearbox, the effect of the connected drive systems must be considered. The section headed Permissible Shaft Loading (page 212) describes the calculation to be undertaken where the transmission mechanism can give rise to radial and/or axial forces on the gear shafts. This occurs, particularly, where chain and belt drives are employed.</p>	<p>Power transmission is by clutch. From the Transmission Load Factor table (page 210 (<math>f_3</math>)), there are no additional loads to be considered and the selection of gearbox is acceptable.</p>

Series		35	37	38	39	40	42 <sup>#3</sup>
Torque (Nm)	Nominal <sup>#1</sup>	46	115	328	481	1353	6195
	Max Running <sup>#2</sup>	93	187	505	935	3088	7000
	Max Start-Up	140	281	758	1403	4632	10500
Input Speed	Max (rpm)	3000	3000	3000	3000	3000	3000
Thermal Limit	Power (kW)	3.3	9	20.5	49	90	190
Backlash	arcmin	9 to 16	9 to 16	9 to 16	7 to 10	7 to 10	7 to 10
Efficiency (%)		95% - 98%					
Service Life	(hours)	>10000	>10000	>10000	>10000	>10000	>10000
Housing Material		SG Iron	SG Iron	SG Iron	SG Iron	SG Iron	SG Iron
Oil Quantity	Litres	0.14	0.29	0.75	1.71	3.27	7
	Pints	0.24	0.5	1.32	3	5.75	12.3
Weight (kg)	2 Way - 1:1 & 1.5:1	5.25	11	21.75	53.25	125	190
	2 Way - 2:1 +	5.5	11	22	54.5	125	215
	3 Way - 1:1 & 1.5:1	5.5	11.5	22	54.5	128	197
	3 Way - 2:1 +	6	11.5	22.5	55.75	128	223
	4 Way - 1:1 & 1.5:1	6	13	25	64	150	204
	4 Way - 2:1 +	7	14	27	69.5	153	231

The above tables and other torque & power tables are on the basis of the following nominal values:

- 1 Shock-free operation
- 2 Operating time per day = 8 hours
- 3 Maximum 20 starts per hour (torque x 1.5 permissible)
- 4 Duty cycle 100%
- 5 When selecting gearboxes take the thermal capacity into consideration
- 6 Ambient temperature for operation -10° to +50°C permissible

Notes:

- #1 Nominal torque values at running speeds of 1500 rpm
- #2 Maximum running torque value at speed of 10 rpm
- #3 42-Series is Range-N design.

## Lubrication

The oil levels stated in the table above assumes that the gearbox is positioned with all shafts in a horizontal plane. To get the correct lubrication recommendation please supply shaft orientation and operating speeds required as part of the application details provided to Power Jacks with an enquiry.

! All Range-C gearboxes are shipped without lubrication, except for grease filled units.

### Input Speeds: 250 rpm < n < 1500 rpm

For input speeds up to 1500 rpm the oil level in the gearbox should be maintained just below the centre line of the shafts.

### Input Speeds: n > 1500 rpm

For input speeds above 1500 rpm a change in oil level may be required in combination with a breather (vent). Consult Power Jacks for specific application advice.

### Input Speeds: 250 rpm < n

For input speeds below 250 rpm then a grease filled gearbox is recommended.

### Oil Specification

Ambient Temperature	Gear Oil
Below +5C	ISO 150
+5C to +40C	ISO 220
Above +40C	ISO 320

### Grease Specification

Use an EP1 rated grease.



Gear Unit Size		Gear Ratio	Input Speeds										
			10	50	100	250	500	750	1000	1500	2000	2500	3000
Series 35	Power (kW)	1:1	0.1	0.4	0.8	1.7	3.1	4.3	5.4	7.4	8.9	10.3	11.6
		1.5:1	0.04	0.2	0.4	0.7	1.4	2.1	2.6	3.7	4.7	5.8	6.8
		2:1	0.03	0.12	0.2	0.5	0.9	1.2	1.6	2.2	2.9	3.6	4.3
		3:1	0.01	0.03	0.06	0.15	0.31	0.5	0.6	0.9	1.2	1.4	1.7
	Output Torque M2 (Nm)	1:1	93	74	74	63	58	53	50	46	41	38	36
		1.5:1	56	56	56	39	39	39	36	34	32	32	31
2:1		56	44	37	37	33	29	29	27	27	26	26	
3:1		28	16	16	16	17	18	16	16	16	15	15	
Series 37	Power (kW)	1:1	0.2	1	2	4.3	7.7	10.8	13.6	18.5	22.6	26.3	30.6
		1.5:1	0.1	0.5	0.8	1.9	3.5	5	6.4	9	11.5	14.3	17
		2:1	0.1	0.3	0.6	1.3	2.5	3.5	4.5	6.4	8.1	10.1	12
		3:1	0.03	0.11	0.2	0.5	0.8	1.2	1.5	2.1	2.8	3.5	4.2
		4:1	0.01	0.06	0.1	0.2	0.4	0.6	0.8	1.2	1.5	1.9	2.3
	Output Torque M2 (Nm)	1:1	187	187	187	160	144	134	127	115	105	98	95
		1.5:1	140	140	112	106	98	93	89	84	80	80	79
		2:1	187	112	112	97	93	87	84	79	75	75	74
		3:1	84	61	56	56	44	44	42	39	39	39	39
		4:1	37	44	37	29	29	29	29	29	28	28	28
Series 38	Power (kW)	1:1	0.54	2.7	5.3	11.7	21.2	29.9	38	52.6	65.1	76.6	-
		1.5:1	0.2	0.9	1.6	3.4	6.1	8.7	11.1	15.5	19.4	23.6	27.6
		2:1	0.27	0.6	1.2	2.6	4.8	6.9	9	12.8	16.6	20.8	25
		3:1	0.1	0.3	0.5	1.2	2.2	3.1	4	5.7	7.5	9.4	11.1
		4:1	0.03	0.13	0.23	0.7	0.9	1.3	1.7	2.4	3.2	4	4.8
	Output Torque M2 (Nm)	1:1	505	505	495	437	396	373	355	328	304	286	-
		1.5:1	280	252	224	190	171	162	155	145	136	132	129
		2:1	505	224	224	194	179	172	168	159	155	155	155
		3:1	280	168	140	134	123	116	112	106	105	105	103
		4:1	112	97	86	104	67	64	63	59	59	59	59
Series 39	Power (kW)	1:1	1	5	9.8	22.2	38.6	52	62.9	77.2	-	-	-
		1.5:1	0.4	1.8	3.6	9	16.3	23.2	29.7	41.8	52.5	63.6	-
		2:1	0.5	2	3.6	7.9	14.5	20.7	26.6	38	49.5	60.7	71.4
		3:1	0.2	0.8	1.4	3.2	5.9	8.4	10.9	15.6	20.5	25.1	29.4
		4:1	0.1	0.4	0.7	1.6	2.9	4.2	5.4	7.7	10.2	12.5	14.7
	Output Torque M2 (Nm)	1:1	935	935	917	831	722	648	588	481	-	-	-
		1.5:1	505	505	505	505	457	434	416	391	368	357	-
		2:1	935	748	673	591	542	516	497	474	463	454	445
		3:1	561	449	393	359	331	314	306	291	287	281	275
		4:1	374	299	262	239	217	209	202	192	190	187	183
Series 40	Power (kW)	1:1	3.3	16.2	31.8	74.3	126	166	194	-	-	-	-
		1.5:1	1.9	8.9	16.3	36.4	65.6	90.8	112	145	-	-	-
		2:1	1.5	6.8	12.5	28	52	74.8	96.7	139	181	221.5	-
		3:1	0.7	2.6	4.5	10.3	19.2	27.8	36.1	52	68.3	83.6	98.3
		4:1	0.4	1.5	2.8	7	11.7	16.9	21.9	31.6	42.1	51.5	60.5
	Output Torque M2 (Nm)	1:1	3088	3032	2975	2781	2358	2071	1815	-	-	-	-
		1.5:1	2667	2498	2288	2043	1841	1699	1572	1356	-	-	-
		2:1	2807	2545	2339	2096	1946	1866	1809	1734	1693	1658	-
		3:1	1965	1459	1263	1156	1078	1040	1013	973	958	938	919
		4:1	1497	1122	1048	1048	875	843	819	788	787	771	754
Series 42	Power (kW)	1:1	7.5	37.4	74.8	187	374	558	-	-	-	-	-
		1.5:1	3.5	17.3	34.5	86.1	172	245	310	-	-	-	-
		2:1	3.7	17.6	32.6	73.8	138	198	255	361	-	-	-
		3:1	0.72	3.6	7.2	18	37.1	53.4	68.3	98.4	128.5	157.3	-
		4:1	1	3.7	6.7	14.9	28	40.6	52.8	76.3	97.7	119.7	140.8
	Output Torque M2 (Nm)	1:1	7000	7000	7000	7000	7000	6962	-	-	-	-	-
		1.5:1	4913	4856	4842	4834	4828	4585	4351	-	-	-	-
		2:1	6925	6588	6101	5525	5165	4941	4772	4504	-	-	-
		3:1	2021	2021	2021	2021	2083	1998	1917	1841	1803	1766	-
		4:1	3743	2770	2508	2231	2096	2026	1976	1904	1828	1972	1756

 Check Thermal Limit - Power

 Check Thermal Limit - Torque

 Power Ratings (kW) @ given INPUT speeds (rpm)  
 Output Torque M2 (Nm) @ given INPUT speeds (rpm)

## Shock Load Factor ( $f_1$ )

Shock Load Category		
I	II	III
Conveyor Belts	Heavy Duty Lifts	Punching Machine
Generators	Hoists	Shears
Ventilators	Mixers	Forging Presses
Light Textile Machinery	Cranes	Vibrators
Rotating Machine Tools	Heavy Duty Textile Machinery	Rolling Mills
	Woodworking Machinery	Extremely Heavy Lifts
	Paper Machinery	Heavy Duty Roller Conveyors

Shock Load Category	Input Power Source								
	Electric Motor			Piston Machine Hydro Motor			Single Cylinder Piston Machine		
	Operating Time per Day (hrs)			Operating Time per Day (hrs)			Operating Time per Day (hrs)		
	≤2	10	>10	≤2	10	>10	≤2	10	>10
I	0.9	1	1.25	1	1.25	1.5	1.25	1.5	1.75
II	1	1.25	1.5	1.25	1.5	1.75	1.5	1.75	2
III	1.5	1.5	1.75	1.75	2	2.25	2	2.25	2.5

## Starting Frequency Factor ( $f_2$ )

up to 20 starts per hour  $f_2 = 1.0$

up to 60 starts per hour  $f_2 = 1.1$

up to 200 starts per hour  $f_2 = 1.3$

up to 600 starts per hour  $f_2 = 1.5$

more than 600 starts per hour (on request)

## Transmission Load Factor ( $f_3$ )

The total load on the drive shafts and their bearing is the result of:

- The loads arising from the gear teeth
- The axial and radial loads arising from the transmission mechanisms attached to the drive shafts. It is this load which must be considered when selecting the gearbox and shaft sizes.

Depending upon the type of transmission mechanism used in connecting the gear shafts to the driving and driven loads, axial and / or radial loads can be applied to the gearbox shafts and their bearings.

These loads can arise from:

- either preload, due for example, to tension loading in belts
- or dynamic forces, due for example, to out-of-balance in the transmission element
- or shock load, due for example, to snatching in a chain drive.

The following table gives the factors which should be used to correct the Output Torque when sizing the gearbox.

Transmission Mechanism	Transmission Load Factor ( $f_3$ )	
	Preload	Dynamic
Clutches	-	1
Gears of all Types	-	1.00 to 1.25
Chains	1.00 to 1.25	1.25 to 1.50
Flat Belts	2.00 to 2.50	1.00 to 1.25
V-Belts, Toothed Belts	1.50 to 2.00	1.00 to 1.25

Due to the compact design of this range of spiral bevel gear units the ratings are controlled by the thermal capacity at some speeds. A maximum case temperature of 80°C is specified and temperatures in excess of this figure normally indicate either incorrect oil levels or too much power being handled by the unit. If this temperature is exceeded Power Jacks should be consulted.

### Thermal Limit - Duty Cycle - Factor ( $f_4$ )

Duty cycle per hour is the percentage of the time per hour during which the gearbox will be on-load.

Duty Cycle per Hour (%)	100	80	60	40	20
Thermal Limit Factor, $f_4$	1	1.25	1.5	1.75	2

### Thermal Limit - Ambient Temperature - Factor ( $f_5$ )

Ambient Temperature °C	10	20	30	40	50
Thermal Limit Factor, $f_5$	1.2	1	0.87	0.75	0.62

### Limiting Thermal Capacity

The capacity of some gears is limited by the maximum permissible temperature of the oil bath. The charts below show the limiting thermal capacities, which can be transferred without cooling at an ambient temperature of 20°C and duty cycle of 100% per hour.

Series	35	37	38	39	40	42
Power (kW)	3.3	9	20.5	49	90	190

WARNING: The case temperature must not exceed 80°C, (see thermal limits).

Power Jacks should be consulted if a gear unit is to be installed with a shaft positioned vertically.

After selecting the gearbox for the required duty it is necessary to check that the axial and radial loading arising from the transmission mechanism is acceptable for the gear shaft diameters on the selected gearbox (gear shaft diameters are given on the Dimensions page for the chosen design).

The bearing configuration on the shafting, the shaft diameter and the shaft speed determine the permissible external loading which can be carried by the shaft without bearing or shaft failure. The graph showing permissible radial forces on shafts has been drawn for a typical Output Shaft. In this arrangement the bearing centres are mounted at either end of the through shaft and there is a significant span which allows higher radial loads to be accepted, see sketch below. For typical Input Shafts and Output Shafts, which are overhung from the gearbox face, the bearing centres are closer together and the radial load carrying capacity is reduced, see sketch below.

To calculate the Permissible Loading on the gearbox shafts, use the gearbox output and input speeds and diameters respectively.

1. Read off the Permissible radial Force for the nearest diameter shafts from the graph below.
2. Use the Correction Factors, below, to calculate the Permissible Radial and Axial Loads for each of the gearbox shafts.

### Correction Factors

	Output Shaft (Bearings on through shaft)	Input Shaft (Bearings on overhung shaft)	Output Shaft (Bearings on overhung shaft)	Gearboxes with Centre bearing
Permissible Radial Forces	1.00	0.66	0.66	0.40
Permissible Axial Forces	0.50	0.50	0.50	0.50

The calculated loads should be checked against the radial and axial loads provided by the manufacturer of the transmission mechanism. If the loading created by the transmission mechanism exceeds the permissible level, a gearbox with a larger diameter shaft is required. At this point Power Jacks should be consulted as it is often possible to fit a special shaft arrangement into a standard gearbox.

### Permissible Shaft Loading Curves

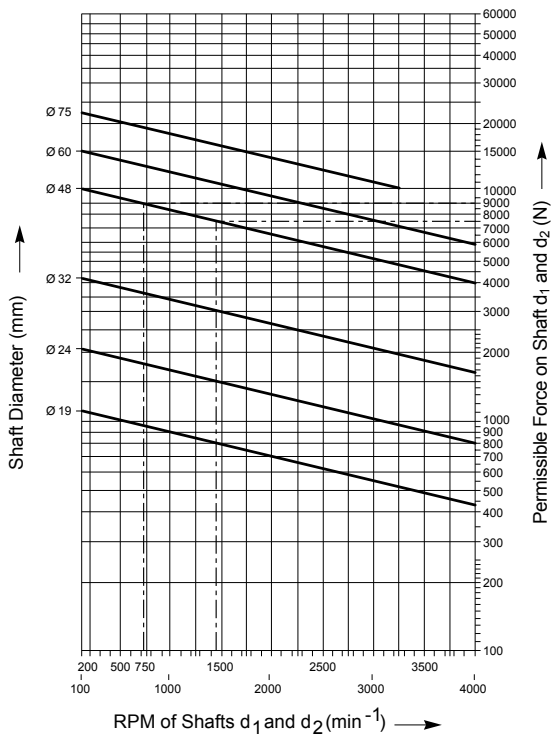

Permissible Shaft Loading Curves

### Example: Series 39, Ratio 2:1, 1440 rpm Input

$\varnothing d1$	=	48	permissible radial force 7500 N x 0.66 = 4950 N permissible axial force 4950 N x 0.50 = 2475 N
$\varnothing d2$	=	48	permissible radial force 9000 N x 1.00 = 9000 N permissible axial force 9000 N x 0.50 = 4500 N

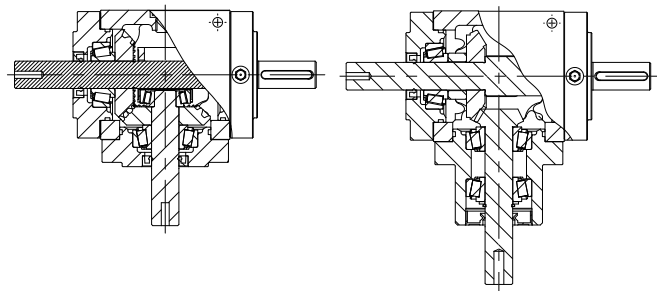

Ratios 1:1 & 1.5:1

Ratios 2:1 & above

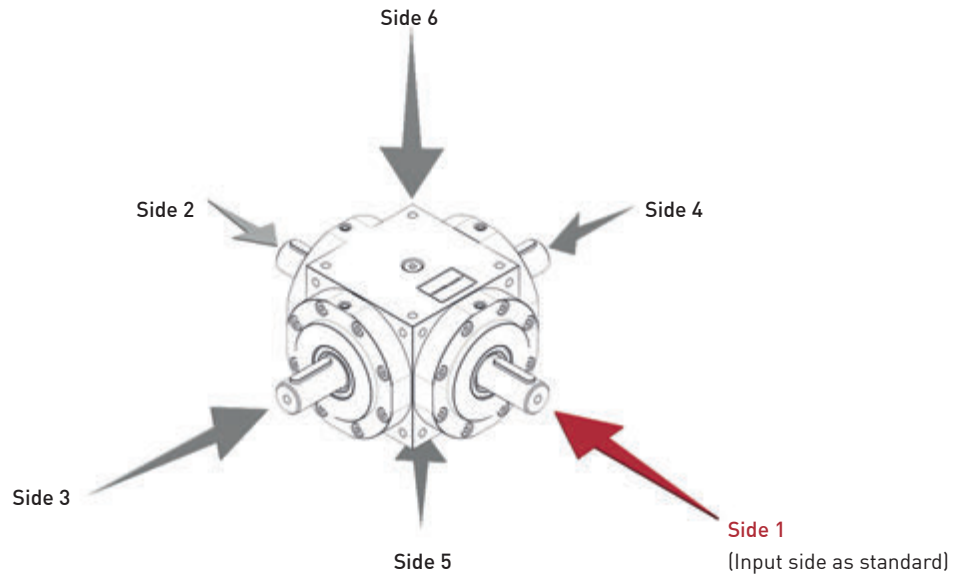

Ratio 1:1 & 1.5:1



Ratio 2:1 & Above

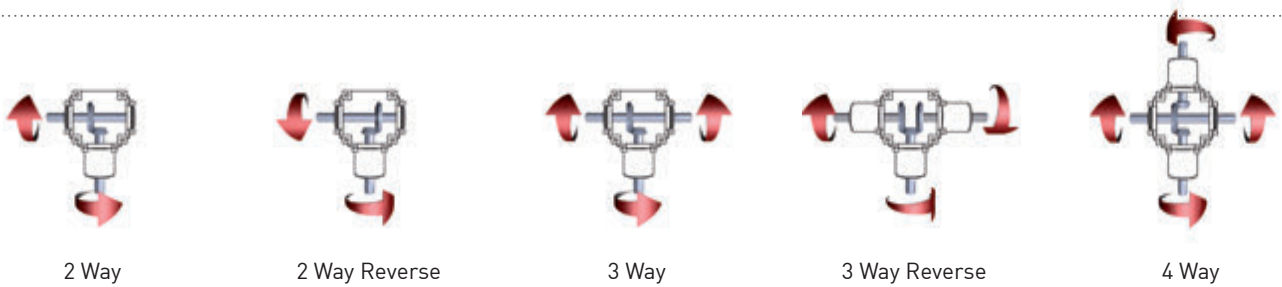

Hollow Shaft - All Ratios



## Performance

Series 35		
Torque (Nm)	Nominal#1	46
	Max Running#2	93
	Max Start-Up	140
Input Speed	Max (rpm)	3000
Thermal Limit	Power (kW)	3.3
Backlash	arcmin	9 to 16
Efficiency	(%)	95% - 98%
Service Life	(hours)	>10000
Housing Material		SG Iron
Oil Quantity	Litres	0.14
	Pints	0.24
Weight (kg)	2 Way - 1:1 & 1.5:1	5.25
	3 Way - 1:1 & 1.5:1	5.5
	4 Way - 1:1 & 1.5:1	6



















### Notes:

#1 Nominal torque values at running speeds of 1500 rpm

#2 Maximum running torque value at speed of 10 rpm

Full detailed performance for each unit refer to page 16 & 17

## Accessories & Options

	Special Gear Ratio		Motor Flange
	Extended Drive Shaft		Limit Switches
	Drives		Light Weight Design
	Reinforced Shaft OR High Torque		Breather
	90° Breather		Mounting Feet
	Shaft Cover		Stainless Steel
	Submersible		Corrosion Protection
	Nuclear Rated		Food Grade
	Low Temperature		High Temperature

## 2 Way Solid Shaft

C350S20-10

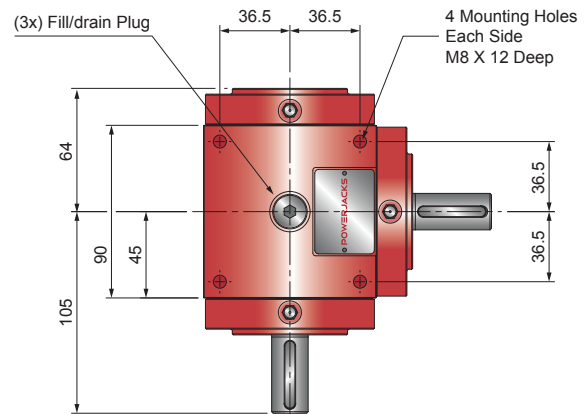

Tapped hole in end of each solid drive shaft - M6 x 16mm Deep

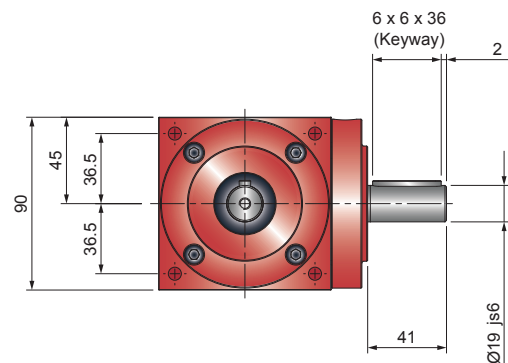

### Notes:

1. All dimensions in mm unless otherwise stated
2. Dimensions subject to change without notice

## 3 Way Solid Shaft

C350S30-10

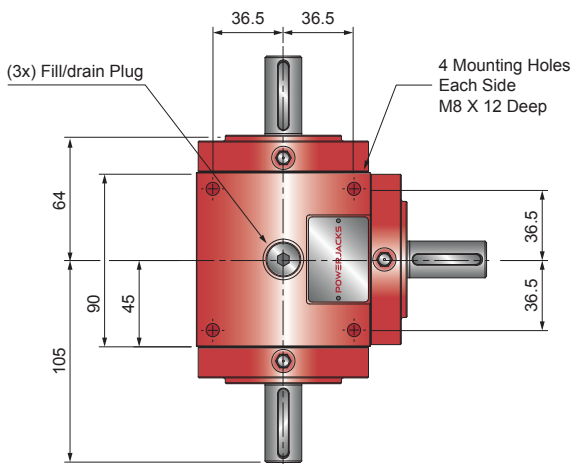
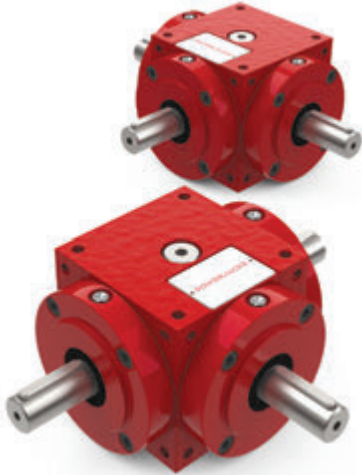

Tapped hole in end of each solid drive shaft - M6 x 16mm Deep

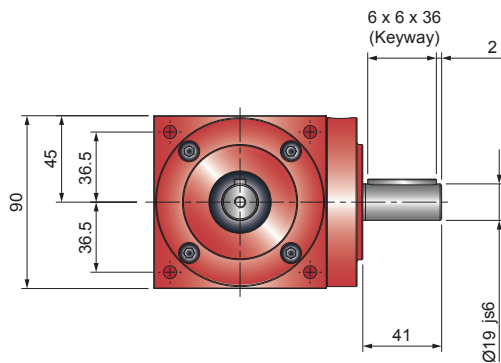

Notes:

1. All dimensions in mm unless otherwise stated
2. Dimensions subject to change without notice

## 4 Way Solid Shaft

C350S40-10

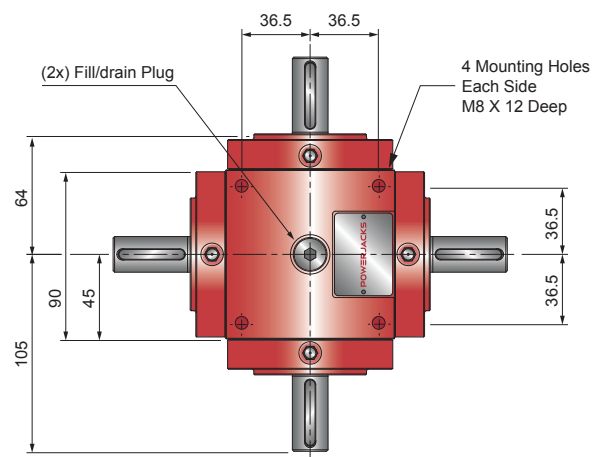

Tapped hole in end of each solid drive shaft - M6 x 16mm Deep

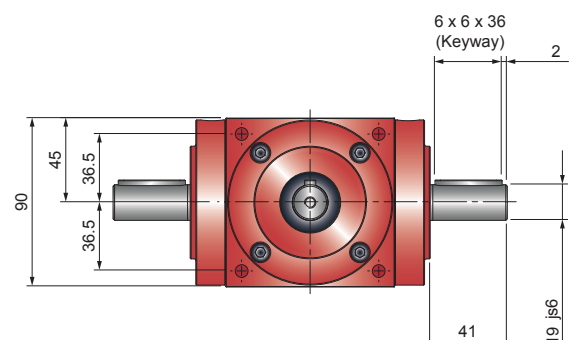

Notes:

1. All dimensions in mm unless otherwise stated
2. Dimensions subject to change without notice





















### Performance

Series 35		
Torque (Nm)	Nominal#1	46
	Max Running#2	93
	Max Start-Up	140
Input Speed	Max (rpm)	3000
Thermal Limit	Power (kW)	3.3
Backlash	arcmin	9 to 16
Efficiency	(%)	95% - 98%
Service Life	(hours)	>10000
Housing Material		SG Iron
Oil Quantity	Litres	0.14
	Pints	0.24
Weight (kg)	2 Way - 2:1 +	5.5
	3 Way - 2:1 +	6
	4 Way - 2:1 +	7

**Notes:**

#1 Nominal torque values at running speeds of 1500 rpm  
 #2 Maximum running torque value at speed of 10 rpm  
 Full detailed performance for each unit refer to page 16 & 17

### Accessories & Options

	Special Gear Ratio		Motor Flange
	Extended Drive Shaft		Limit Switches
	Drives		Light Weight Design
	Reinforced Shaft OR High Torque		Breather
	90° Breather		Mounting Feet
	Shaft Cover		Stainless Steel
	Submersible		Corrosion Protection
	Nuclear Rated		Food Grade
	Low Temperature		High Temperature

### 2 Way Solid Shaft

C350S20-20

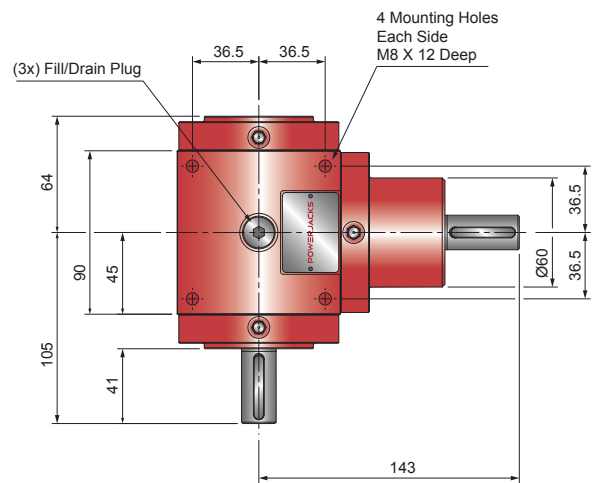

Tapped hole in end of each solid drive shaft - M6 x 16mm Deep

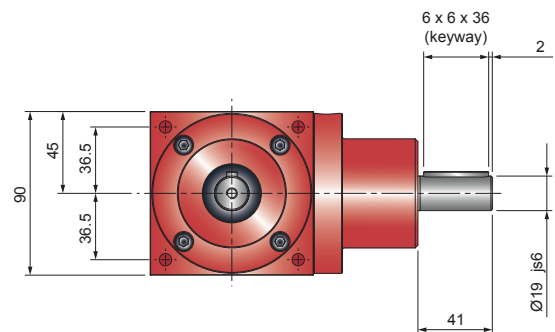

**Notes:**

1. All dimensions in mm unless otherwise stated
2. Dimensions subject to change without notice

### 3 Way Solid Shaft

C350S30-20

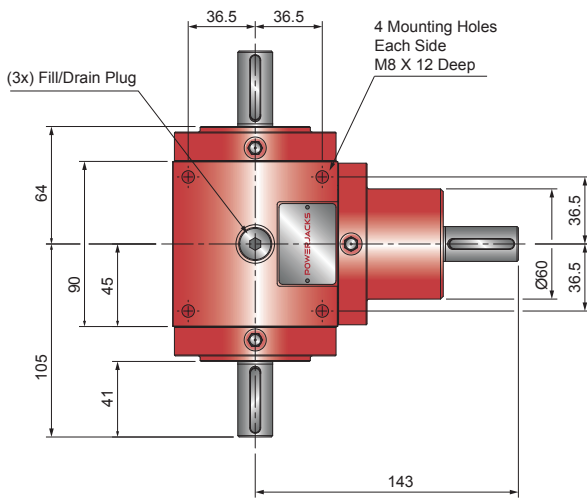

Tapped hole in end of each solid drive shaft - M6 x 16mm Deep

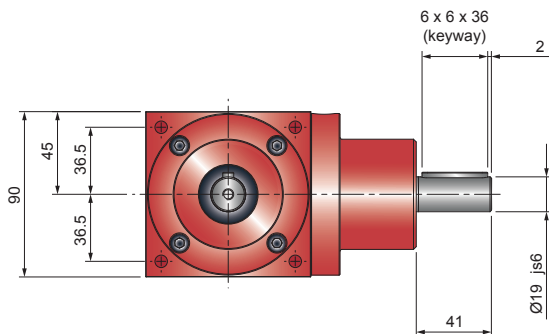

#### Notes:

1. All dimensions in mm unless otherwise stated
2. Dimensions subject to change without notice

### 4 Way Solid Shaft

C350S40-20

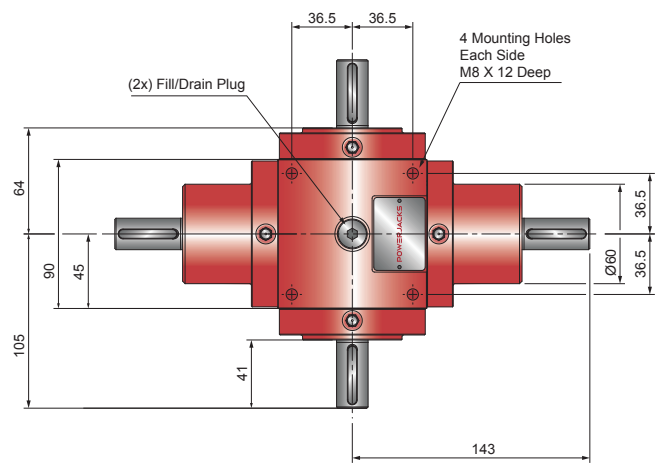

Tapped hole in end of each solid drive shaft - M6 x 16mm Deep

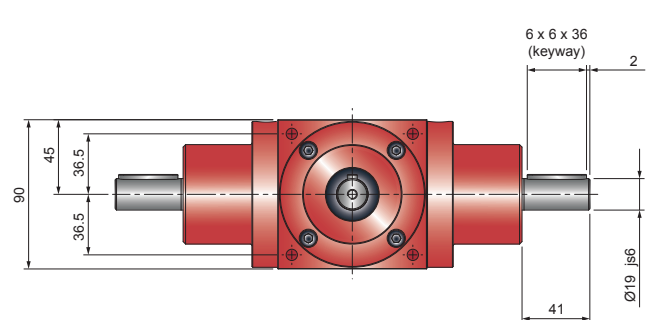

#### Notes:

1. All dimensions in mm unless otherwise stated
2. Dimensions subject to change without notice



















### Performance

Series 35		
Torque (Nm)	Nominal#1	46
	Max Running#2	93
	Max Start-Up	140
Input Speed	Max (rpm)	3000
Thermal Limit	Power (kW)	3.3
Backlash	arcmin	9 to 16
Efficiency	(%)	95% - 98%
Service Life	(hours)	>10000
Housing Material		SG Iron
Oil Quantity	Litres	0.14
	Pints	0.24
Weight (kg)	2 Way - 1:1 & 1.5:1	5.25
	2 Way - 2:1 +	5.5
	3 Way - 1:1 & 1.5:1	5.5
	3 Way - 2:1 +	6
	4 Way - 1:1 & 1.5:1	6
	4 Way - 2:1 +	7

**Notes:**

#1 Nominal torque values at running speeds of 1500 rpm  
 #2 Maximum running torque value at speed of 10 rpm  
 Full detailed performance for each unit refer to page 16 & 17

### Accessories & Options

	Special Gear Ratio		Motor Flange
	Extended Drive Shaft		Limit Switches
	Drives		Light Weight Design
	Reinforced Shaft OR High Torque		Breather
	90° Breather		Mounting Feet
	Shaft Cover		Stainless Steel
	Submersible		Corrosion Protection
	Nuclear Rated		Food Grade
	Low Temperature		High Temperature

### 2 Way Hollow Shaft

C350H20-10

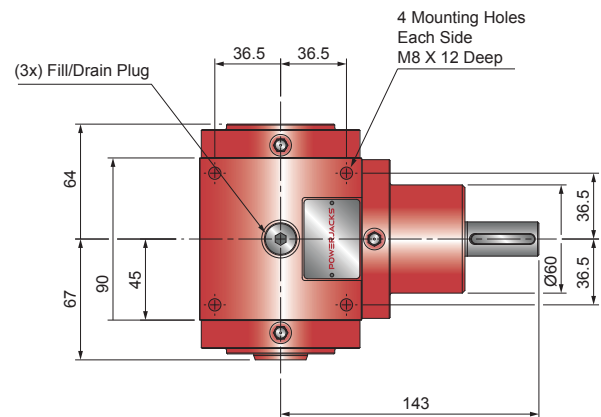

Tapped hole in end of each solid drive shaft - M6 x 16mm Deep

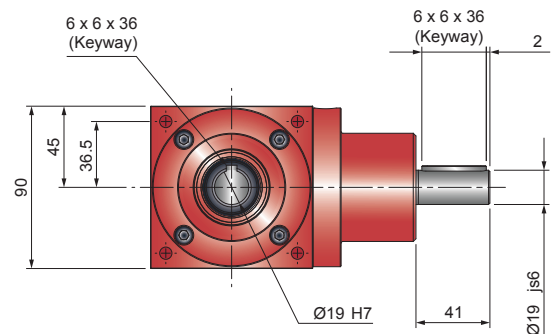

**Notes:**

1. All dimensions in mm unless otherwise stated
2. Dimensions subject to change without notice

### 3 Way Hollow Shaft

C350H30-10

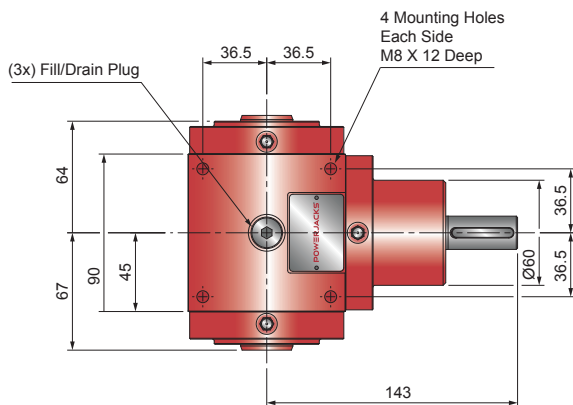

Tapped hole in end of each solid drive shaft - M6 x 16mm Deep

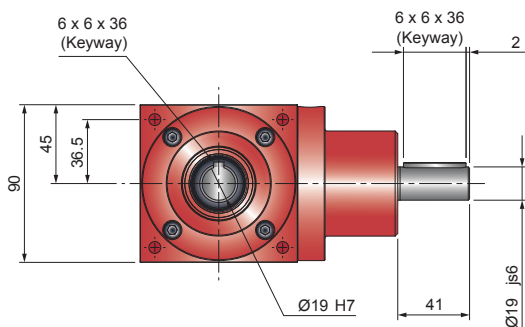

**Notes:**

1. All dimensions in mm unless otherwise stated
2. Dimensions subject to change without notice

### 4 Way Hollow Shaft

C350H40-10

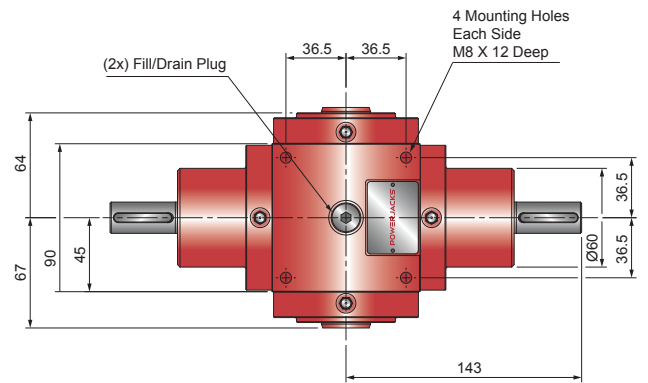

Tapped hole in end of each solid drive shaft - M6 x 16mm Deep

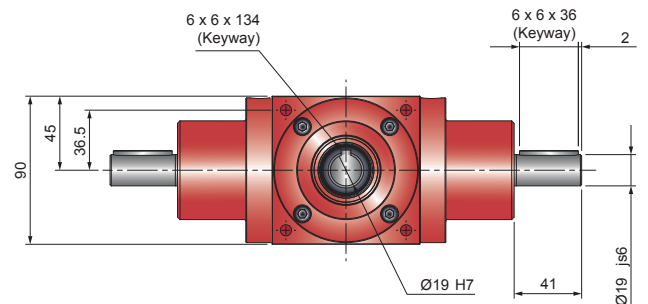

**Notes:**

1. All dimensions in mm unless otherwise stated
2. Dimensions subject to change without notice



















## Performance

Series 37		
Torque (Nm)	Nominal#1	115
	Max Running#2	187
	Max Start-Up	281
Input Speed	Max (rpm)	3000
Thermal Limit	Power (kW)	9
Backlash	arcmin	9 to 16
Efficiency	(%)	95% - 98%
Service Life	(hours)	>10000
Housing Material		SG Iron
Oil Quantity	Litres	0.29
	Pints	0.5
Weight (kg)	2 Way - 1:1 & 1.5:1	11
	3 Way - 1:1 & 1.5:1	11.5
	4 Way - 1:1 & 1.5:1	13

### Notes:

#1 Nominal torque values at running speeds of 1500 rpm  
 #2 Maximum running torque value at speed of 10 rpm  
 Full detailed performance for each unit refer to page 16 & 17

## Accessories & Options

	Special Gear Ratio		Motor Flange
	Extended Drive Shaft		Limit Switches
	Drives		Light Weight Design
	Reinforced Shaft OR High Torque		Breather
	90° Breather		Mounting Feet
	Shaft Cover		Stainless Steel
	Submersible		Corrosion Protection
	Nuclear Rated		Food Grade
	Low Temperature		High Temperature

## 2 Way Solid Shaft

C370S20-10

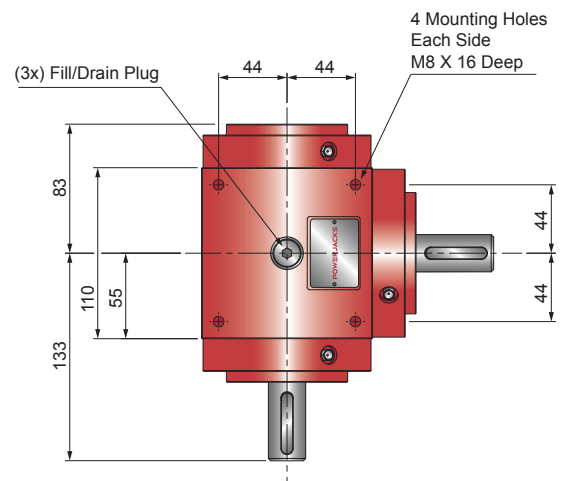

Tapped hole in end of each solid drive shaft - M8 x 25mm Deep

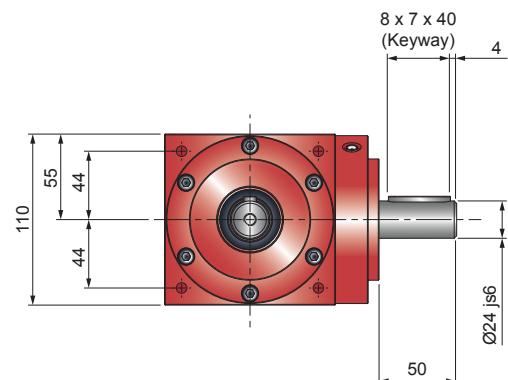

### Notes:

1. All dimensions in mm unless otherwise stated
2. Dimensions subject to change without notice



## 3 Way Solid Shaft

C370S30-10

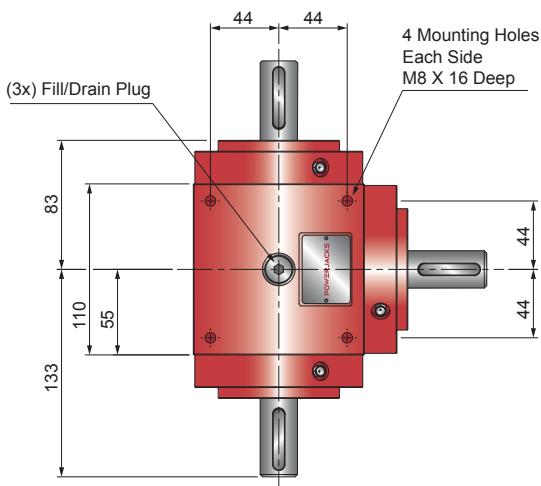

Tapped hole in end of each solid drive shaft - M8 x 25mm Deep

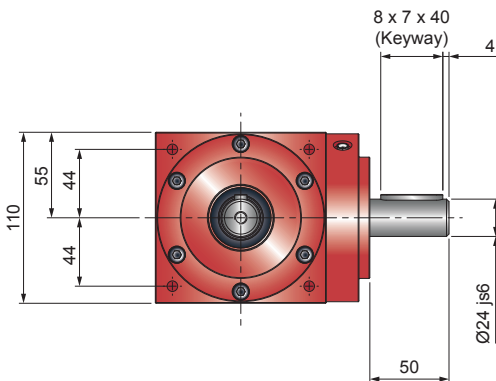

### Notes:

1. All dimensions in mm unless otherwise stated
2. Dimensions subject to change without notice

## 4 Way Solid Shaft

C370S40-10

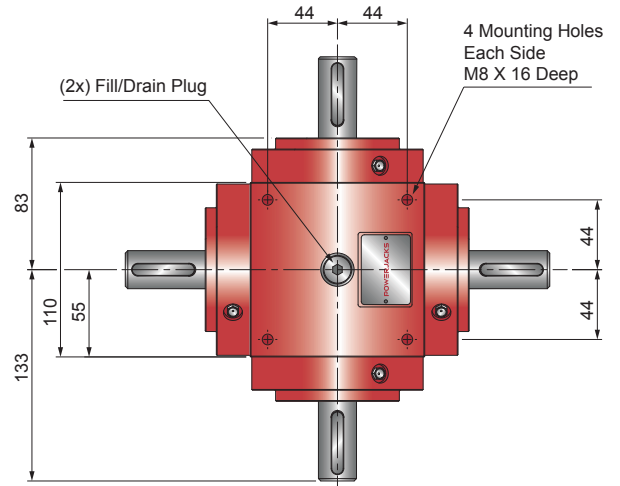

Tapped hole in end of each solid drive shaft - M8 x 25mm Deep

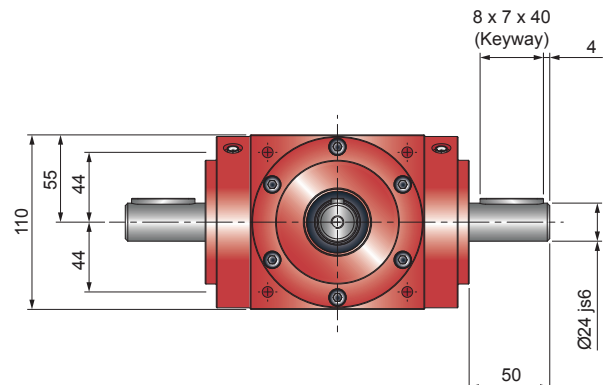

### Notes:

1. All dimensions in mm unless otherwise stated
2. Dimensions subject to change without notice





## 3 Way Solid Shaft

C370S30-20

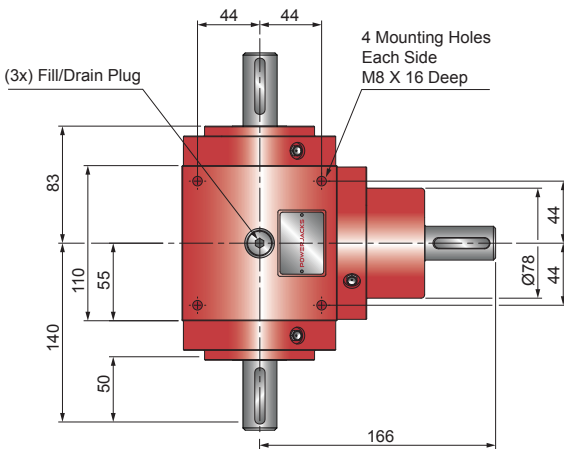

Tapped hole in end of each solid drive shaft - M8 x 25mm Deep

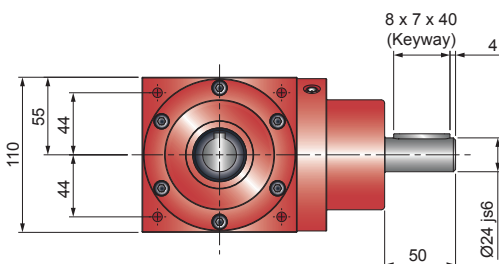

### Notes:

1. All dimensions in mm unless otherwise stated
2. Dimensions subject to change without notice

## 4 Way Solid Shaft

C370S40-20

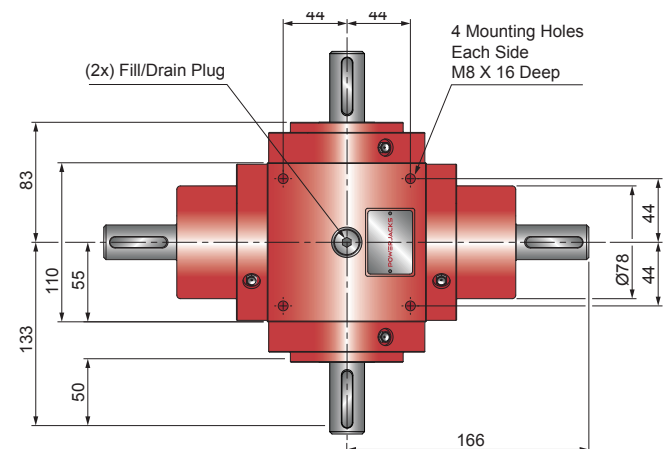

Tapped hole in end of each solid drive shaft - M8 x 25mm Deep

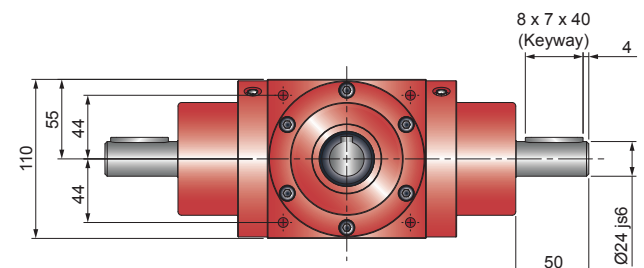

### Notes:

1. All dimensions in mm unless otherwise stated
2. Dimensions subject to change without notice

### Performance

Series 37		
Torque (Nm)	Nominal#1	115
	Max Running#2	187
	Max Start-Up	281
Input Speed	Max (rpm)	3000
Thermal Limit	Power (kW)	9
Backlash	arcmin	9 to 16
Efficiency	(%)	95% - 98%
Service Life	(hours)	>10000
Housing Material		SG Iron
Oil Quantity	Litres	0.29
	Pints	0.5
Weight (kg)	2 Way - 1:1 & 1.5:1	11
	2 Way - 2:1 +	11
	3 Way - 1:1 & 1.5:1	11.5
	3 Way - 2:1 +	11.5
	4 Way - 1:1 & 1.5:1	13
	4 Way - 2:1 +	14

Notes:

#1 Nominal torque values at running speeds of 1500 rpm  
 #2 Maximum running torque value at speed of 10 rpm  
 Full detailed performance for each unit refer to page 16 & 17

### Accessories & Options

	Special Gear Ratio		Motor Flange
	Extended Drive Shaft		Limit Switches
	Drives		Light Weight Design
	Reinforced Shaft OR High Torque		Breather
	90° Breather		Breather
	Shaft Cover		Mounting Feet
	Submersible		Stainless Steel
	Nuclear Rated		Corrosion Protection
	Low Temperature		Food Grade
	High Temperature		

### 2 Way Hollow Shaft

C370H20-10

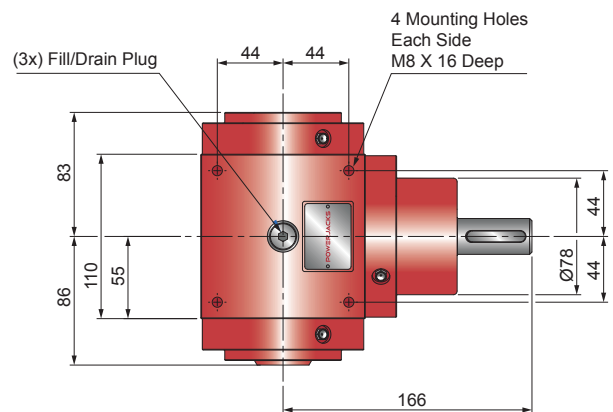

Tapped hole in end of each solid drive shaft - M8 x 25mm Deep

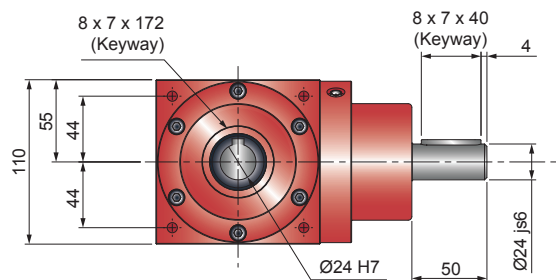

Notes:

1. All dimensions in mm unless otherwise stated
2. Dimensions subject to change without notice

### 3 Way Hollow Shaft

C370H30-10

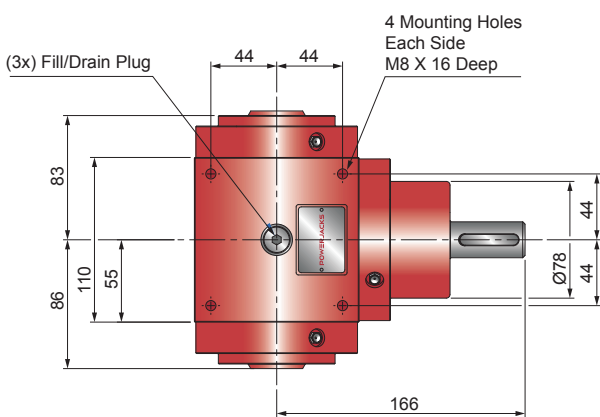

Tapped hole in end of each solid drive shaft - M8 x 25mm Deep

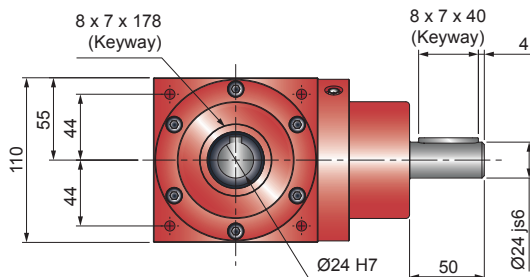

Notes:

- All dimensions in mm unless otherwise stated
1. All dimensions subject to change without notice
  2. Dimensions subject to change without notice

### 4 Way Hollow Shaft

C370H40-10

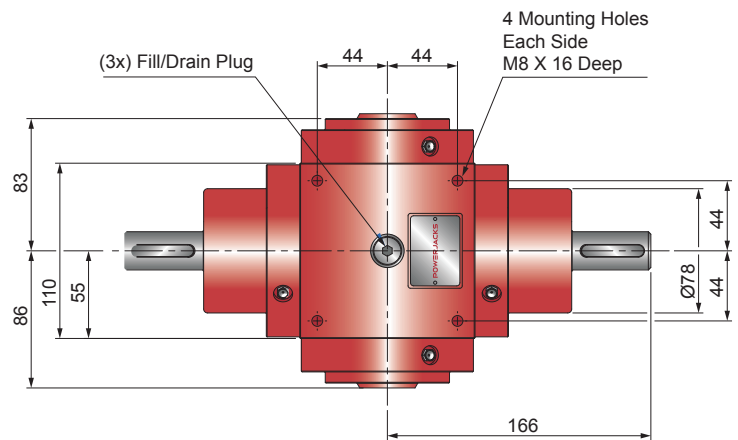

Tapped hole in end of each solid drive shaft - M8 x 25mm Deep

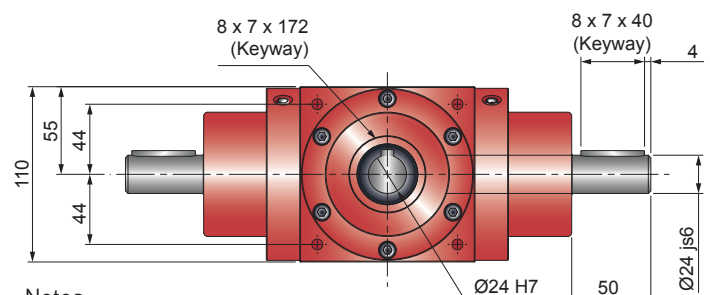

Notes:

- All dimensions in mm unless otherwise stated
1. All dimensions subject to change without notice
  2. Dimensions subject to change without notice



















### Performance

Series 38		
Torque (Nm)	Nominal#1	328
	Max Running#2	505
	Max Start-Up	758
Input Speed	Max [rpm]	3000
Thermal Limit	Power (kW)	20.5
Backlash	arcmin	9 to 16
Efficiency	(%)	95% - 98%
Service Life	(hours)	>10000
Housing Material		SG Iron
Oil Quantity	Litres	0.75
	Pints	1.32
Weight (kg)	2 Way - 1:1 & 1.5:1	21.75
	3 Way - 1:1 & 1.5:1	22
	4 Way - 1:1 & 1.5:1	25

**Notes:**

#1 Nominal torque values at running speeds of 1500 rpm  
 #2 Maximum running torque value at speed of 10 rpm  
 Full detailed performance for each unit refer to page 16 & 17

### Accessories & Options

	Special Gear Ratio		Motor Flange
	Extended Drive Shaft		Limit Switches
	Drives		Light Weight Design
	Reinforced Shaft OR High Torque		Breather
	90° Breather		Mounting Feet
	Shaft Cover		Stainless Steel
	Submersible		Corrosion Protection
	Nuclear Rated		Food Grade
	Low Temperature		High Temperature

### 2 Way Solid Shaft

C380S20-10

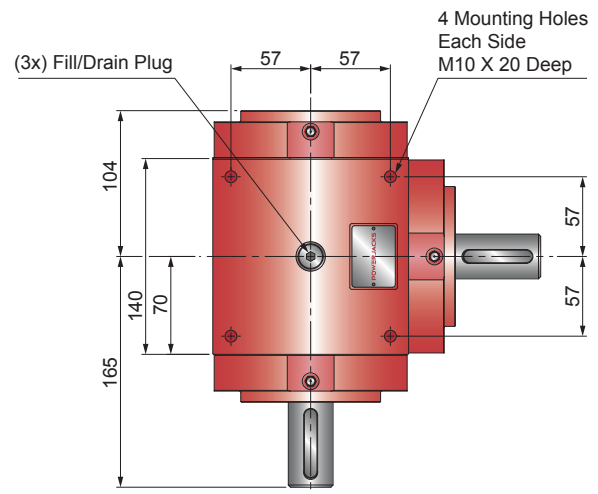

Tapped hole in end of each solid drive shaft - M10 x 25mm Deep

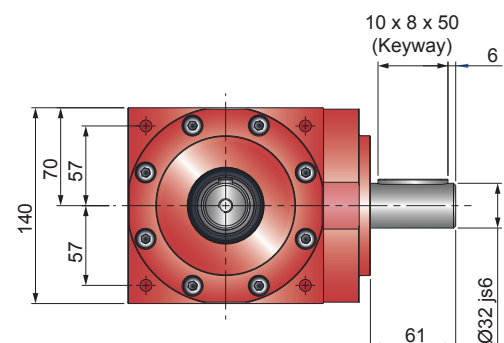

**Notes:**

1. All dimensions in mm unless otherwise stated
2. Dimensions subject to change without notice

## 3 Way Solid Shaft

C380S30-10

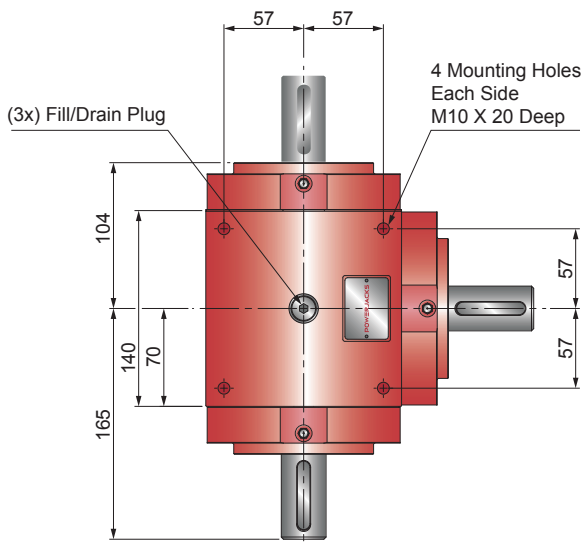

Tapped hole in end of each solid drive shaft - M10 x 25mm Deep

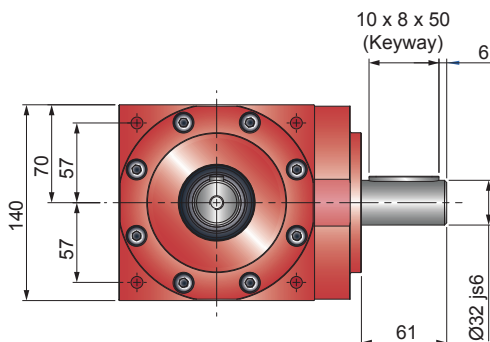

Notes:  
 1. All dimensions in mm unless otherwise stated  
 2. Dimensions subject to change without notice  
 2. Dimensions subject to change without notice

## 4 Way Solid Shaft

C380S40-10

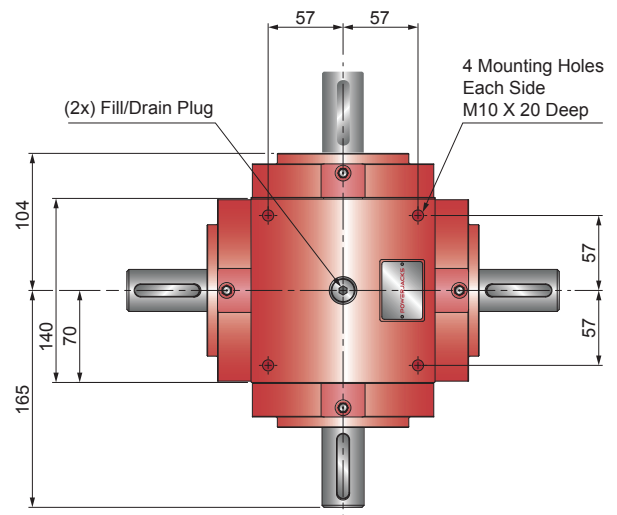

Tapped hole in end of each solid drive shaft - M10 x 25mm Deep

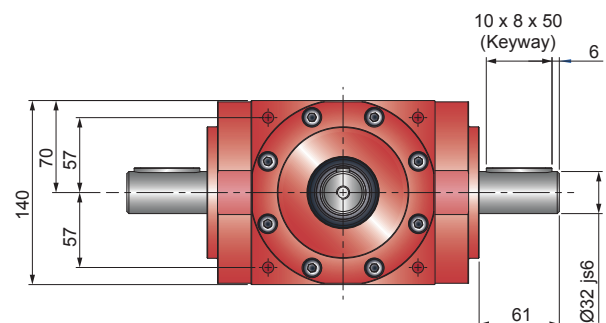

Notes:  
 1. All dimensions in mm unless otherwise stated  
 2. Dimensions subject to change without notice  
 2. Dimensions subject to change without notice





















### Performance

Series 38		
Torque (Nm)	Nominal#1	328
	Max Running#2	505
	Max Start-Up	758
Input Speed	Max (rpm)	3000
Thermal Limit	Power (kW)	20.5
Backlash	arcmin	9 to 16
Efficiency	(%)	95% - 98%
Service Life	(hours)	>10000
Housing Material		SG Iron
Oil Quantity	Litres	0.75
	Pints	1.32
Weight (kg)	2 Way - 2:1 +	21
	3 Way - 2:1 +	22.5
	4 Way - 2:1 +	27

**Notes:**

#1 Nominal torque values at running speeds of 1500 rpm  
 #2 Maximum running torque value at speed of 10 rpm  
 Full detailed performance for each unit refer to page 16 & 17

### Accessories & Options

	Special Gear Ratio		Motor Flange
	Extended Drive Shaft		Limit Switches
	Drives		Light Weight Design
	Reinforced Shaft OR High Torque		Breather
	90° Breather		Mounting Feet
	Shaft Cover		Stainless Steel
	Submersible		Corrosion Protection
	Nuclear Rated		Food Grade
	Low Temperature		High Temperature

### 2 Way Solid Shaft

C380S20-20

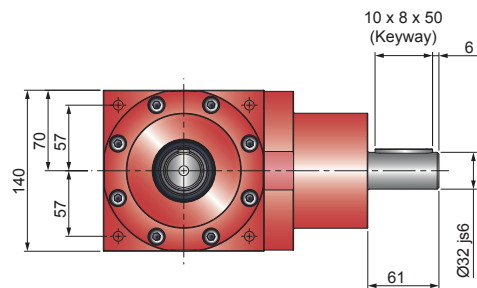
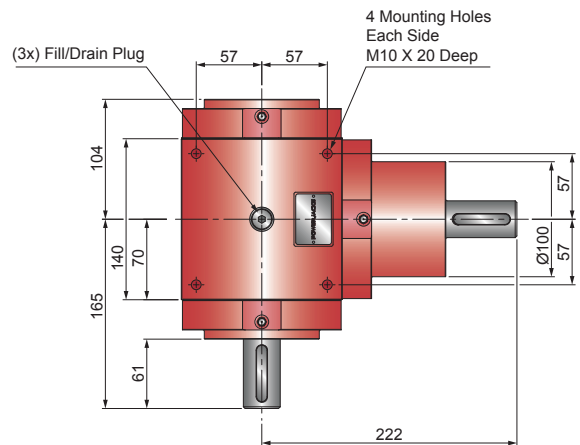

**Notes:**

1. All dimensions in mm unless otherwise stated
2. Dimensions subject to change without notice

## 3 Way Solid Shaft

C380S30-20

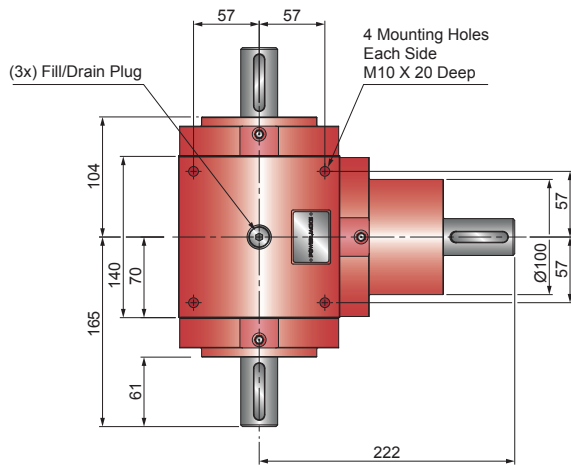

Tapped hole in end of each solid drive shaft - M10 x 25mm Deep

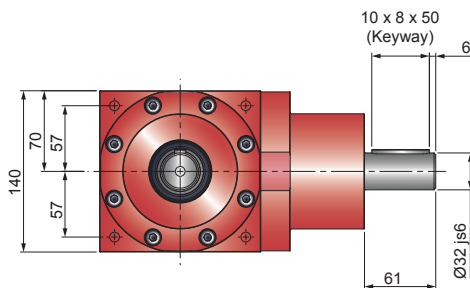

### Notes:

1. All dimensions in mm unless otherwise stated
2. Dimensions subject to change without notice

## 4 Way Solid Shaft

C380S40-20

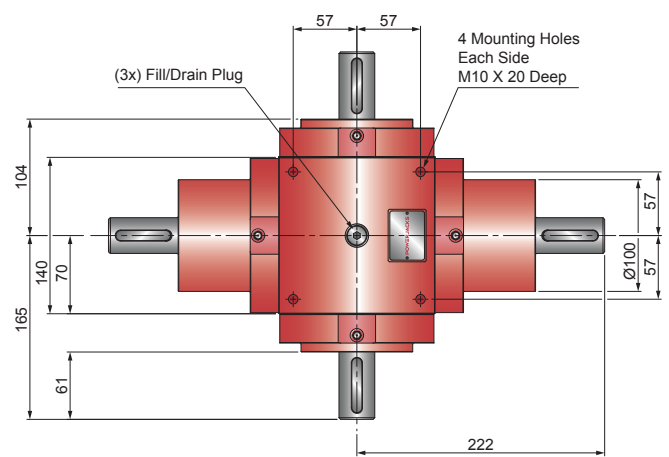

Tapped hole in end of each solid drive shaft - M10 x 25mm Deep

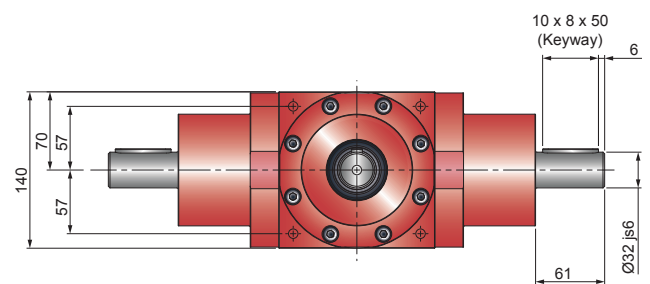

### Notes:

1. All dimensions in mm unless otherwise stated
2. Dimensions subject to change without notice



### Performance

Series 38		
Torque (Nm)	Nominal#1	328
	Max Running#2	505
	Max Start-Up	758
Input Speed	Max (rpm)	3000
Thermal Limit	Power (kW)	20.5
Backlash	arcmin	9 to 16
Efficiency	(%)	95% - 98%
Service Life	(hours)	>10000
Housing Material		SG Iron
Oil Quantity	Litres	0.75
	Pints	1.32
Weight (kg)	2 Way - 1:1 & 1.5:1	21.75
	2 Way - 2:1 +	22
	3 Way - 1:1 & 1.5:1	22
	3 Way - 2:1 +	22.5
	4 Way - 1:1 & 1.5:1	25
	4 Way - 2:1 +	27



















**Notes:**

#1 Nominal torque values at running speeds of 1500 rpm

#2 Maximum running torque value at speed of 10 rpm

Full detailed performance for each unit refer to page 16 & 17

### Accessories & Options

	Special Gear Ratio		Motor Flange
	Extended Drive Shaft		Limit Switches
	Drives		Light Weight Design
	Reinforced Shaft OR High Torque		Breather
	90° Breather		Mounting Feet
	Shaft Cover		Stainless Steel
	Submersible		Corrosion Protection
	Nuclear Rated		Food Grade
	Low Temperature		High Temperature

### 2 Way Hollow Shaft

C380H20-10

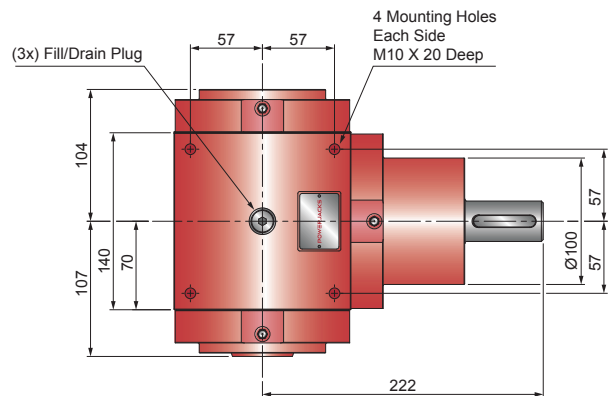

Tapped hole in end of each solid drive shaft - M10 x 25mm Deep

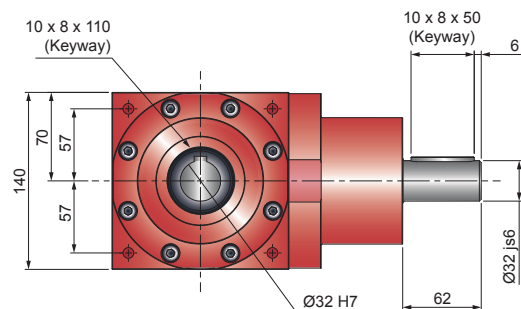

**Notes:**

1. All dimensions in mm unless otherwise stated
2. Dimensions subject to change without notice

### 3 Way Hollow Shaft

C380H30-10

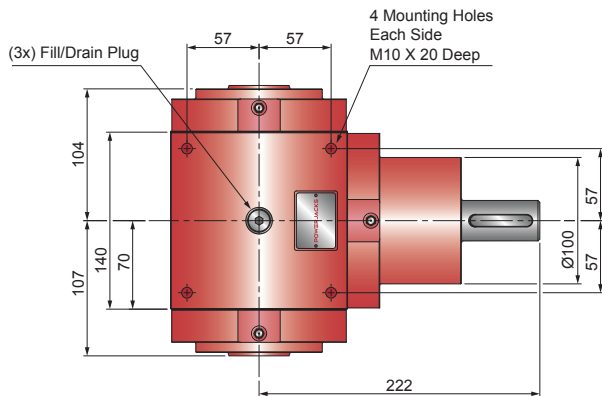

Tapped hole in end of each solid drive shaft - M10 x 25mm Deep

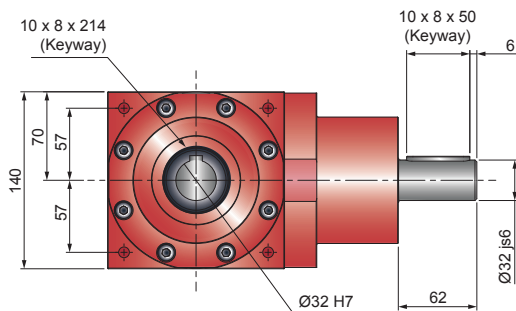

**Notes:**

1. All dimensions in mm unless otherwise stated
2. Dimensions subject to change without notice

### 4 Way Hollow Shaft

C380H40

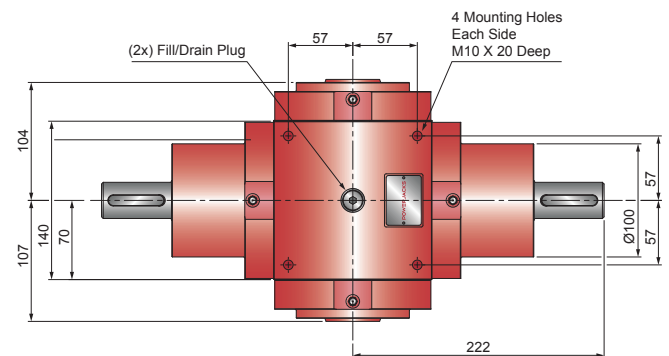

Tapped hole in end of each solid drive shaft - M10 x 25mm Deep

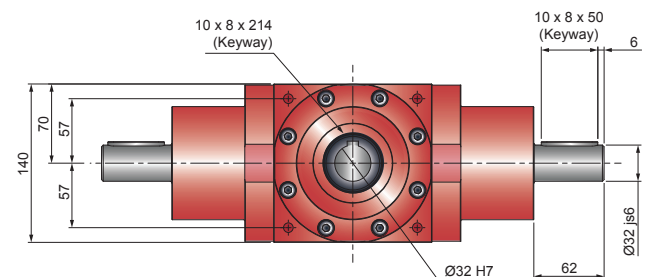

**Notes:**

1. All dimensions in mm unless otherwise stated
2. Dimensions subject to change without notice



















## Performance

Series 39		
Torque (Nm)	Nominal#1	481
	Max Running#2	935
	Max Start-Up	1403
Input Speed	Max (rpm)	3000
Thermal Limit	Power (kW)	49
Backlash	arcmin	7 to 10
Efficiency	(%)	95% - 98%
Service Life	(hours)	>10000
Housing Material		SG Iron
Oil Quantity	Litres	1.71
	Pints	3
Weight (kg)	2 Way - 1:1 & 1.5:1	53.25
	3 Way - 1:1 & 1.5:1	54.5
	4 Way - 1:1 & 1.5:1	64

### Notes:

#1 Nominal torque values at running speeds of 1500 rpm  
 #2 Maximum running torque value at speed of 10 rpm  
 Full detailed performance for each unit refer to page 16 & 17

## Accessories & Options

	Special Gear Ratio		Motor Flange
	Extended Drive Shaft		Limit Switches
	Drives		Light Weight Design
	Reinforced Shaft OR High Torque		Breather
	90° Breather		Mounting Feet
	Shaft Cover		Stainless Steel
	Submersible		Corrosion Protection
	Nuclear Rated		Food Grade
	Low Temperature		High Temperature

## 2 Way Solid Shaft

C390S20-10

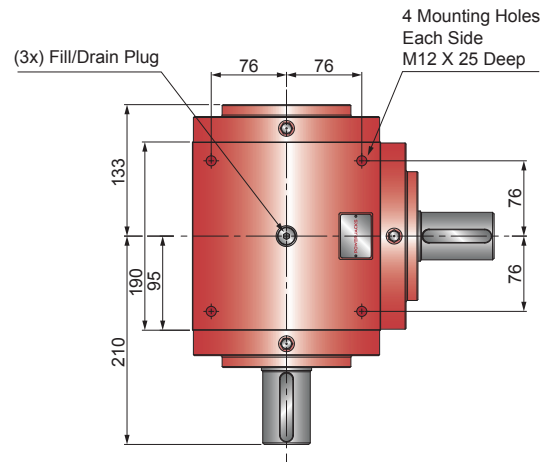

Tapped hole in end of each solid drive shaft - M12 x 30mm Deep

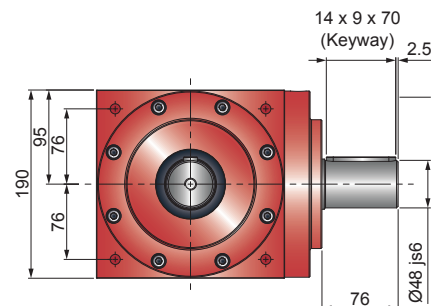

### Notes:

1. All dimensions in mm unless otherwise stated
2. Dimensions subject to change without notice

## 3 Way Solid Shaft

C390S30-10

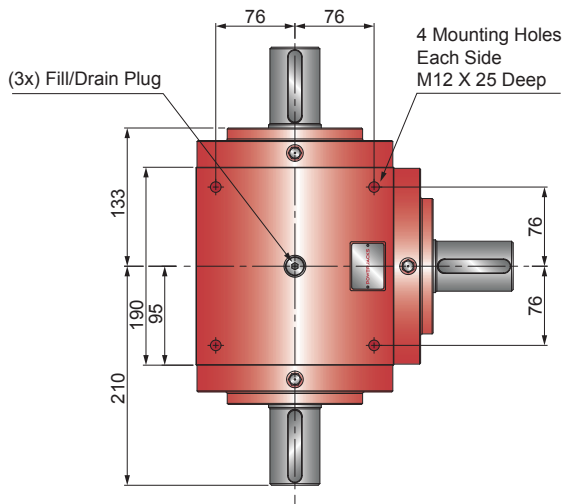
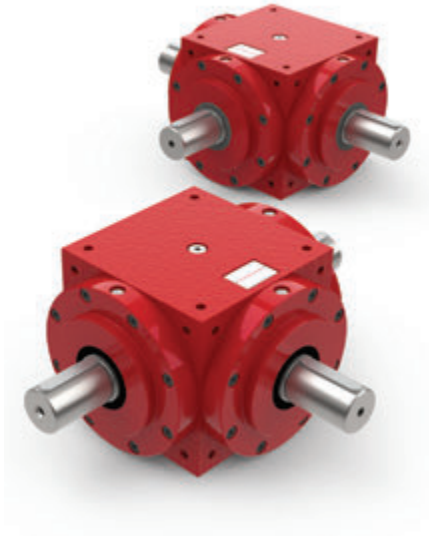

Tapped hole in end of each solid drive shaft - M12 x 30mm Deep

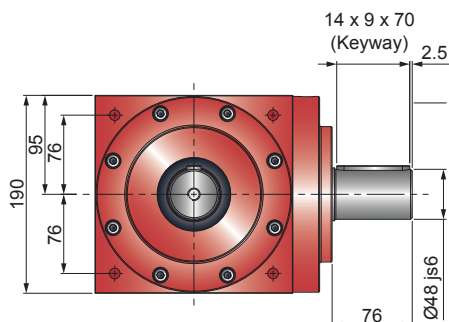

Notes:

1. All dimensions in mm unless otherwise stated
2. Dimensions subject to change without notice

## 4 Way Solid Shaft

C390S40-10

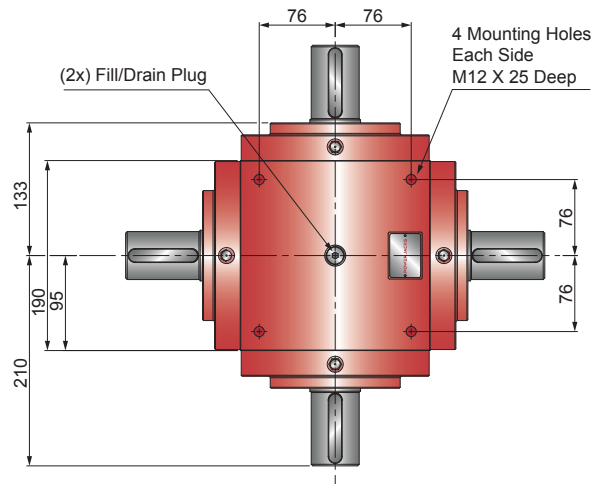

Tapped hole in end of each solid drive shaft - M12 x 30mm Deep

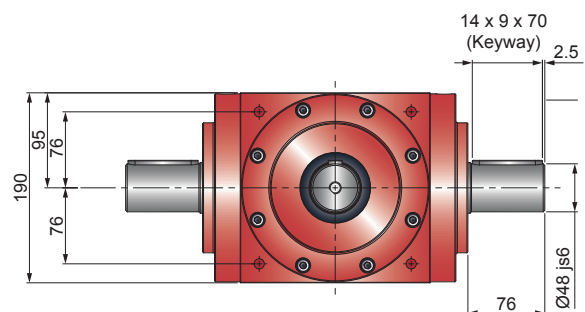

Notes:

1. All dimensions in mm unless otherwise stated
2. Dimensions subject to change without notice



















### Performance

Series 39		
Torque (Nm)	Nominal#1	481
	Max Running#2	935
	Max Start-Up	1403
Input Speed	Max (rpm)	3000
Thermal Limit	Power (kW)	49
Backlash	arcmin	7 to 10
Efficiency	(%)	95% - 98%
Service Life	(hours)	>10000
Housing Material		SG Iron
Oil Quantity	Litres	1.71
	Pints	3
Weight (kg)	2 Way - 2:1 +	54.5
	3 Way - 2:1 +	55.75
	4 Way - 2:1 +	69.5

**Notes:**

#1 Nominal torque values at running speeds of 1500 rpm  
 #2 Maximum running torque value at speed of 10 rpm  
 Full detailed performance for each unit refer to page 16 & 17

### Accessories & Options

	Special Gear Ratio		Motor Flange
	Extended Drive Shaft		Limit Switches
	Drives		Light Weight Design
	Reinforced Shaft OR High Torque		Breather
	90° Breather		Mounting Feet
	Shaft Cover		Stainless Steel
	Submersible		Corrosion Protection
	Nuclear Rated		Food Grade
	Low Temperature		High Temperature

### 2 Way Solid Shaft

C390S20-20

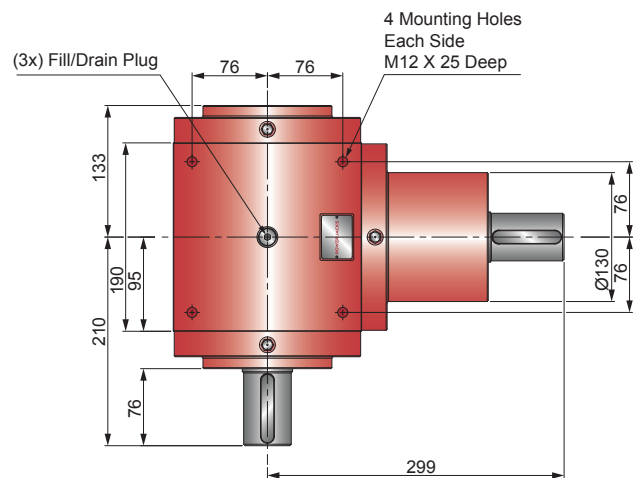
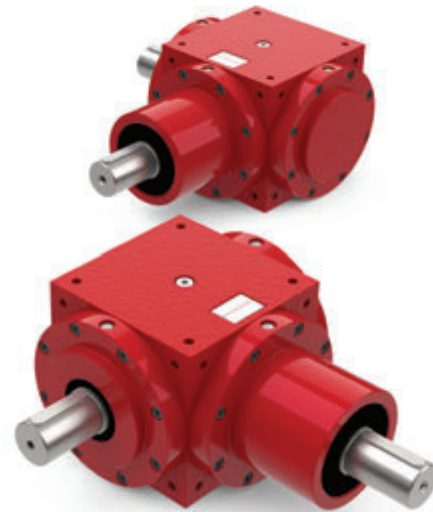

Tapped hole in end of each solid drive shaft - M12 x 30mm Deep

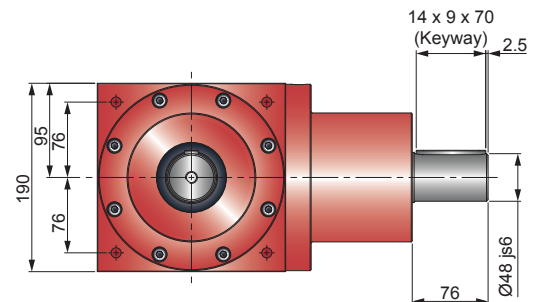

**Notes:**

1. All dimensions in mm unless otherwise stated
2. Dimensions subject to change without notice

## 3 Way Solid Shaft

C390S30-20

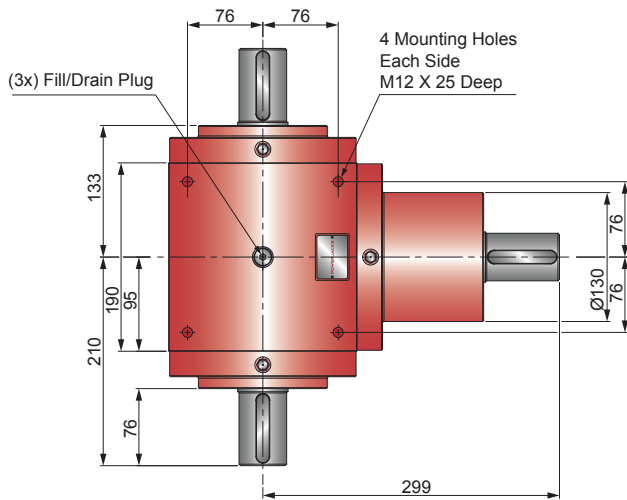

Tapped hole in end of each solid drive shaft - M12 x 30mm Deep

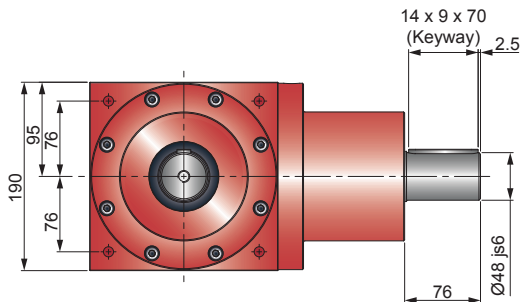

### Notes:

1. All dimensions in mm unless otherwise stated
2. Dimensions subject to change without notice

## 4 Way Solid Shaft

C390S40-20

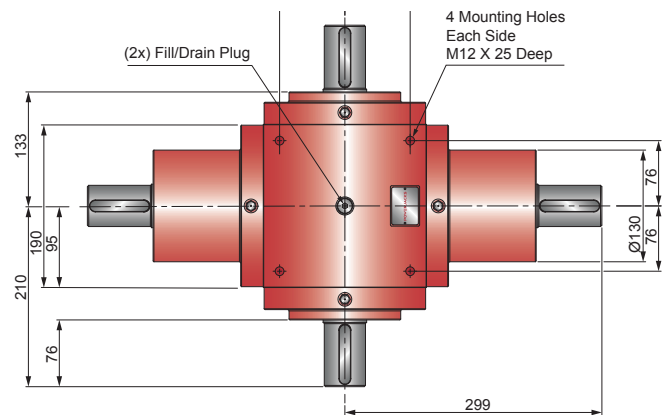

Tapped hole in end of each solid drive shaft - M12 x 30mm Deep

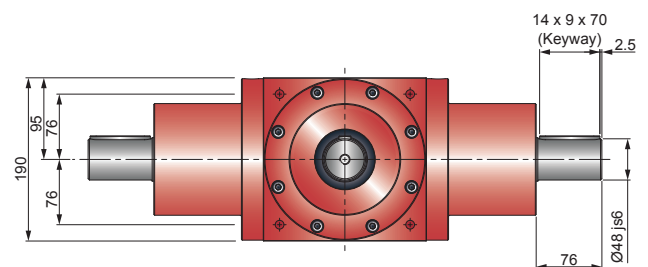

### Notes:

1. All dimensions in mm unless otherwise stated
2. Dimensions subject to change without notice



### Performance

Series 39		
Torque (Nm)	Nominal#1	481
	Max Running#2	935
	Max Start-Up	1403
Input Speed	Max (rpm)	3000
Thermal Limit	Power (kW)	49
Backlash	arcmin	7 to 10
Efficiency	(%)	95% - 98%
Service Life	(hours)	>10000
Housing Material		SG Iron
Oil Quantity	Litres	1.71
	Pints	3
Weight (kg)	2 Way - 1:1 & 1.5:1	53.25
	2 Way - 2:1 +	54.5
	3 Way - 1:1 & 1.5:1	54.5
	3 Way - 2:1 +	55.75
	4 Way - 1:1 & 1.5:1	64
	4 Way - 2:1 +	69.5



















**Notes:**

#1 Nominal torque values at running speeds of 1500 rpm

#2 Maximum running torque value at speed of 10 rpm

Full detailed performance for each unit refer to page 16 & 17

### Accessories & Options

	Special Gear Ratio		Motor Flange
	Extended Drive Shaft		Limit Switches
	Drives		Light Weight Design
	Reinforced Shaft OR High Torque		Breather
	90° Breather		Mounting Feet
	Shaft Cover		Stainless Steel
	Submersible		Corrosion Protection
	Nuclear Rated		Food Grade
	Low Temperature		High Temperature

### 2 Way Hollow Shaft

C390H20-10

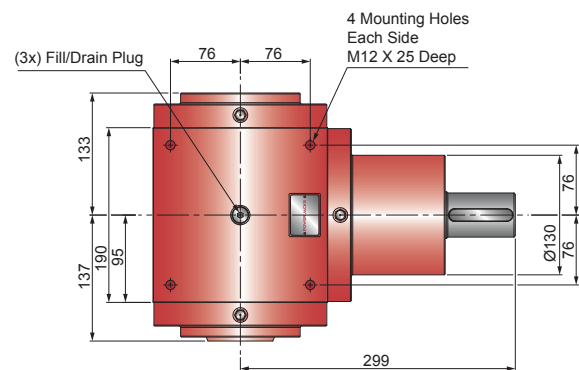

Tapped hole in end of each solid drive shaft - M12 x 30mm Deep

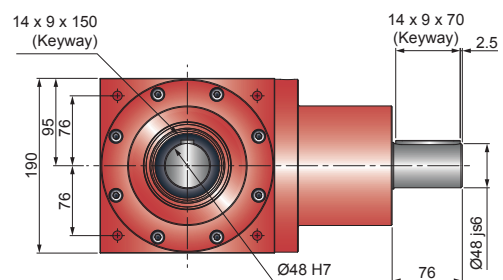

**Notes:**

1. All dimensions in mm unless otherwise stated
2. Dimensions subject to change without notice



### 3 Way Hollow Shaft

C390H30-10

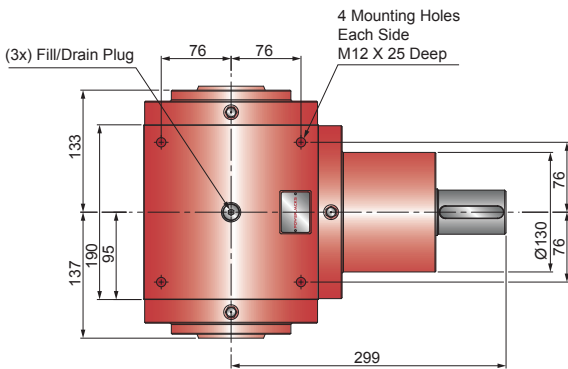

Tapped hole in end of each solid drive shaft - M12 x 30mm Deep

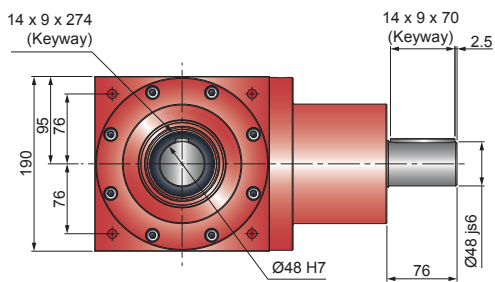

**Notes:**

1. All dimensions in mm unless otherwise stated
2. Dimensions subject to change without notice

### 4 Way Hollow Shaft

C390H40-10

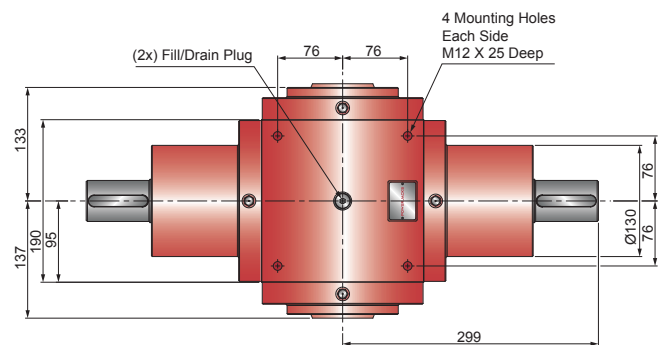

Tapped hole in end of each solid drive shaft - M12 x 30mm Deep

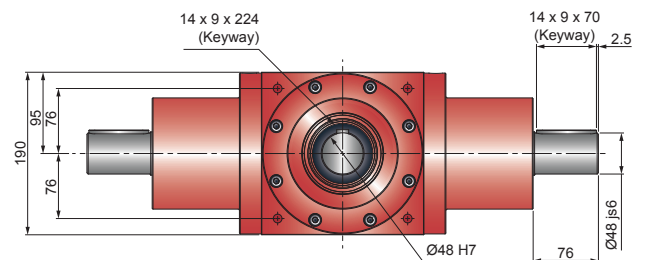

**Notes:**

1. All dimensions in mm unless otherwise stated
2. Dimensions subject to change without notice

## Performance

Series 40		
Torque (Nm)	Nominal#1	1353
	Max Running#2	3088
	Max Start-Up	4632
Input Speed	Max (rpm)	3000
Thermal Limit	Power (kW)	90
Backlash	arcmin	7 to 10
Efficiency	(%)	95% - 98%
Service Life	(hours)	>10000
Housing Material		SG Iron
Oil Quantity	Litres	3.27
	Pints	5.75
Weight (kg)	2 Way - 1:1 & 1.5:1	125
	3 Way - 1:1 & 1.5:1	128
	4 Way - 1:1 & 1.5:1	150



















### Notes:

#1 Nominal torque values at running speeds of 1500 rpm

#2 Maximum running torque value at speed of 10 rpm

Full detailed performance for each unit refer to page 16 & 17

## Accessories & Options

	Special Gear Ratio		Motor Flange
	Extended Drive Shaft		Limit Switches
	Drives		Light Weight Design
	Reinforced Shaft OR High Torque		Breather
	90° Breather		Mounting Feet
	Shaft Cover		Stainless Steel
	Submersible		Corrosion Protection
	Nuclear Rated		Food Grade
	Low Temperature		High Temperature

## 2 Way Solid Shaft

C400S20-10

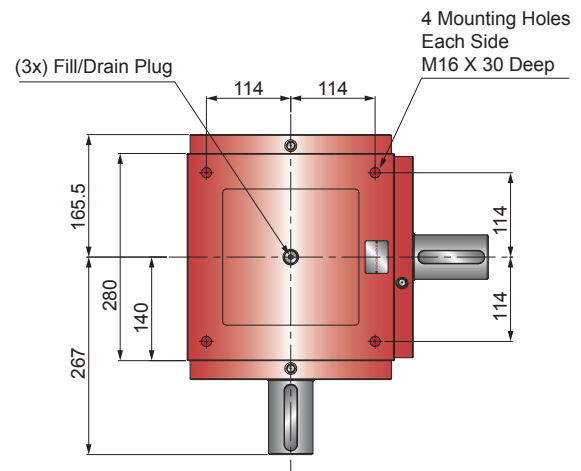
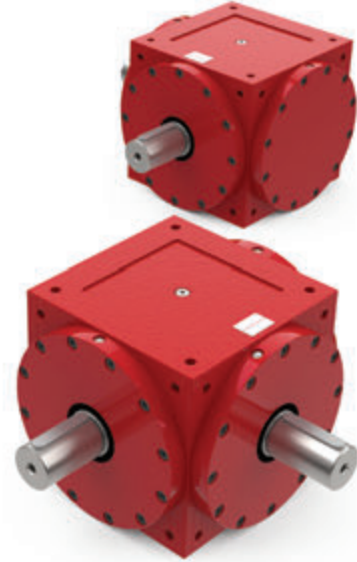

Tapped hole in end of each solid drive shaft - M16 x 38mm Deep

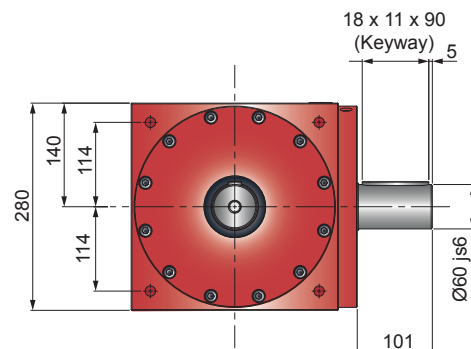

### Notes:

1. All dimensions in mm unless otherwise stated
2. Dimensions subject to change without notice

## 3 Way Solid Shaft

C400S30-10

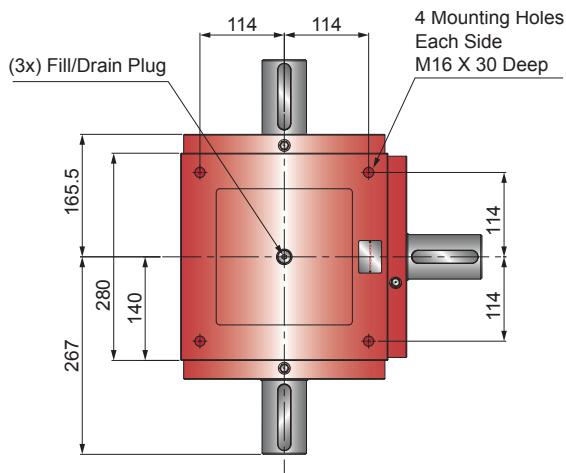
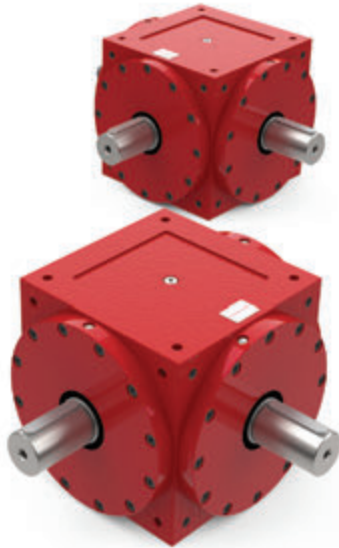

Tapped hole in end of each solid drive shaft - M16 x 38mm Deep

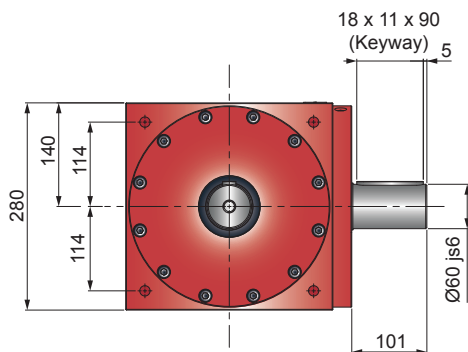

### Notes:

1. All dimensions in mm unless otherwise stated
2. Dimensions subject to change without notice

## 4 Way Solid Shaft

C400S40-10

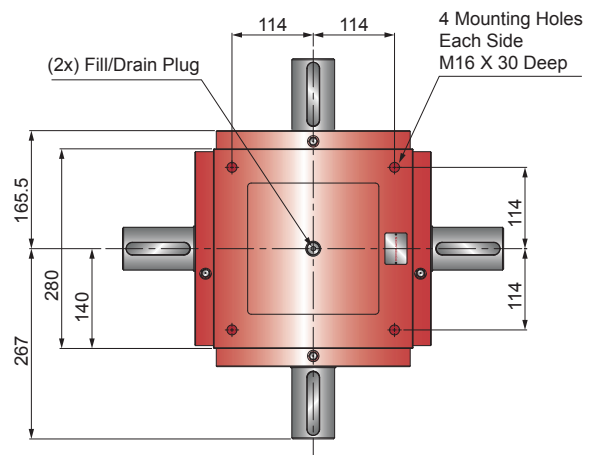

Tapped hole in end of each solid drive shaft - M16 x 38mm Deep

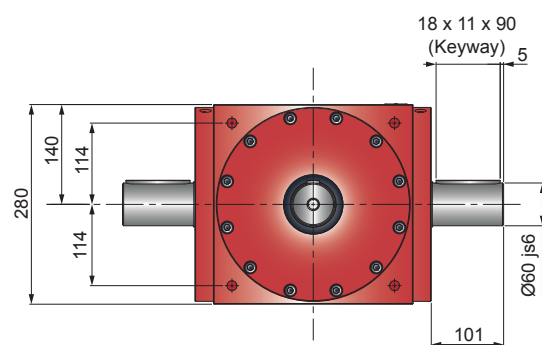

### Notes:

1. All dimensions in mm unless otherwise stated
2. Dimensions subject to change without notice

## Performance

Series 40		
Torque (Nm)	Nominal#1	1353
	Max Running#2	3088
	Max Start-Up	4632
Input Speed	Max (rpm)	3000
Thermal Limit	Power (kW)	90
Backlash	arcmin	7 to 10
Efficiency	(%)	95% - 98%
Service Life	(hours)	>10000
Housing Material		SG Iron
Oil Quantity	Litres	3.27
	Pints	5.75
Weight (kg)	2 Way - 2:1 +	125
	3 Way - 2:1 +	128
	4 Way - 2:1 +	153



















### Notes:

#1 Nominal torque values at running speeds of 1500 rpm

#2 Maximum running torque value at speed of 10 rpm

Full detailed performance for each unit refer to page 16 & 17

## Accessories & Options

	Special Gear Ratio		Motor Flange
	Extended Drive Shaft		Limit Switches
	Drives		Light Weight Design
	Reinforced Shaft OR High Torque		Breather
	90° Breather		Mounting Feet
	Shaft Cover		Stainless Steel
	Submersible		Corrosion Protection
	Nuclear Rated		Food Grade
	Low Temperature		High Temperature

## 2 Way Solid Shaft

C400S20-20

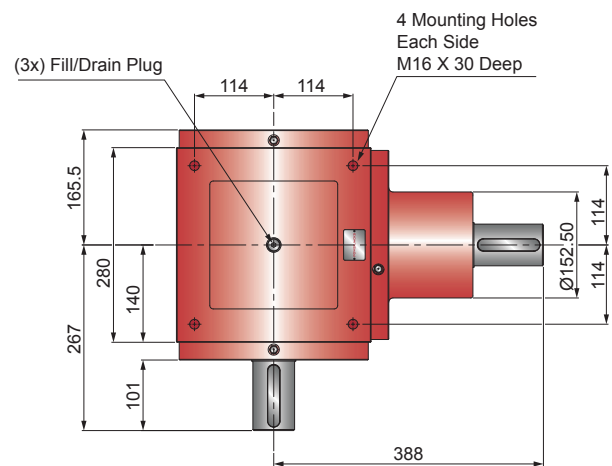
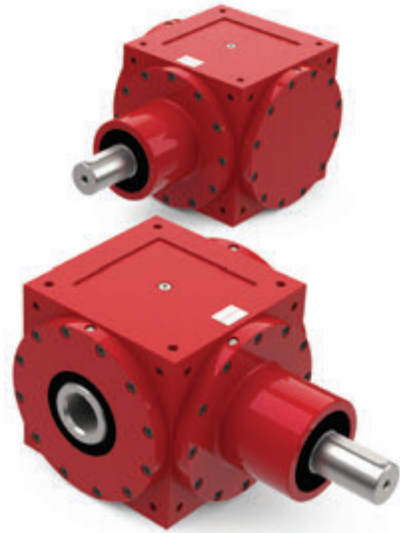

Tapped hole in end of each solid drive shaft - M16 x 38mm Deep

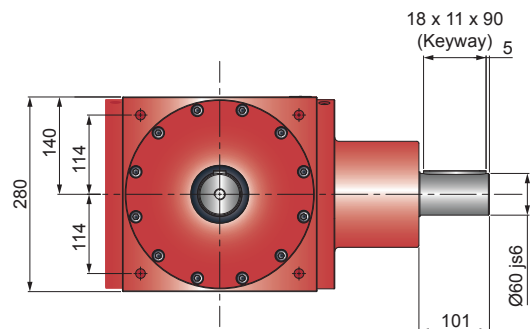

### Notes:

1. All dimensions in mm unless otherwise stated
2. Dimensions subject to change without notice

## 3 Way Solid Shaft

C400S30-20

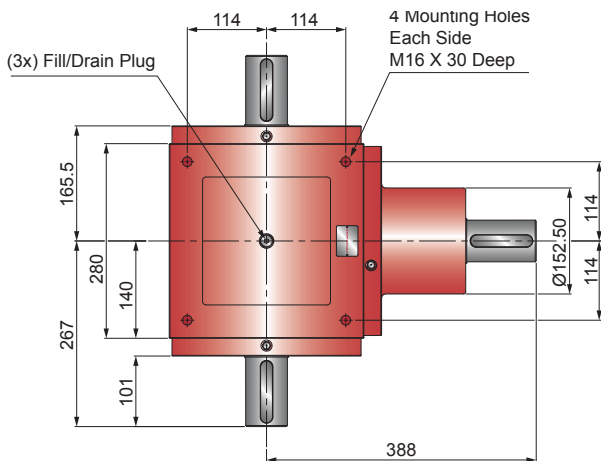
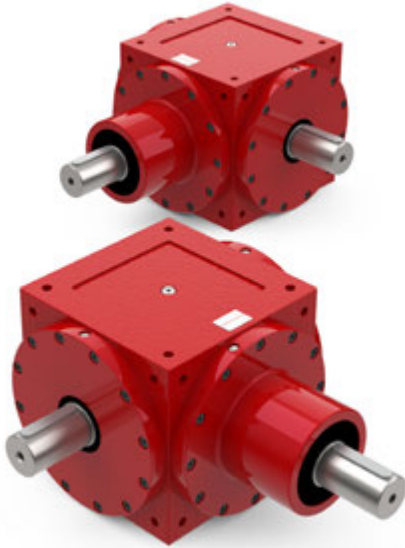

Tapped hole in end of each solid drive shaft - M16 x 38mm Deep

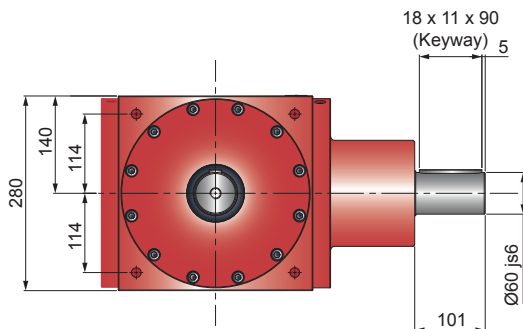

### Notes:

1. All dimensions in mm unless otherwise stated
2. Dimensions subject to change without notice

## 4 Way Solid Shaft

C400S40-20

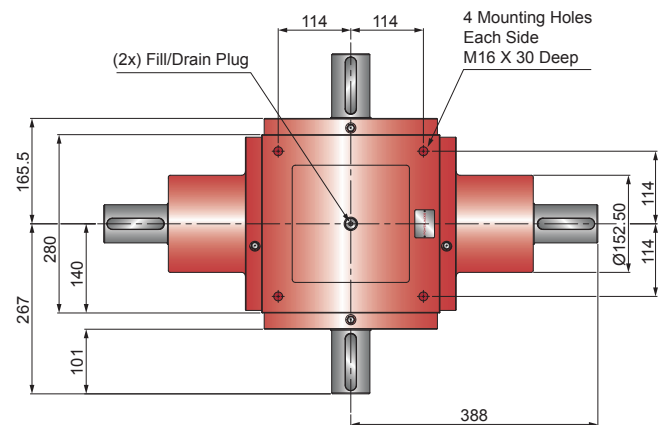

Tapped hole in end of each solid drive shaft - M16 x 38mm Deep

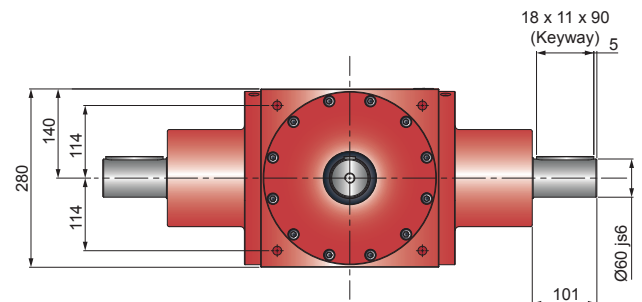

### Notes:

1. All dimensions in mm unless otherwise stated
2. Dimensions subject to change without notice



















### Performance

Series 40		
Torque (Nm)	Nominal#1	1353
	Max Running#2	3088
	Max Start-Up	4632
Input Speed	Max (rpm)	3000
Thermal Limit	Power (kW)	90
Backlash	arcmin	7 to 10
Efficiency	(%)	95% - 98%
Service Life	(hours)	>10000
Housing Material		SG Iron
Oil Quantity	Litres	3.27
	Pints	5.75
Weight (kg)	2 Way - 1:1 & 1.5:1	125
	2 Way - 2:1 +	125
	3 Way - 1:1 & 1.5:1	128
	3 Way - 2:1 +	128
	4 Way - 1:1 & 1.5:1	150
	4 Way - 2:1 +	153

**Notes:**

- #1 Nominal torque values at running speeds of 1500 rpm
- #2 Maximum running torque value at speed of 10 rpm
- Full detailed performance for each unit refer to page 16 & 17

### Accessories & Options

	Special Gear Ratio		Motor Flange
	Extended Drive Shaft		Limit Switches
	Drives		Light Weight Design
	Reinforced Shaft OR High Torque		Breather
	90° Breather		Mounting Feet
	Shaft Cover		Stainless Steel
	Submersible		Corrosion Protection
	Nuclear Rated		Food Grade
	Low Temperature		High Temperature

### 2 Way Hollow Shaft

C400H20-10

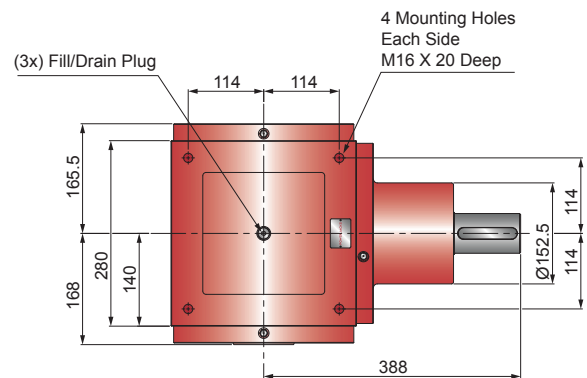
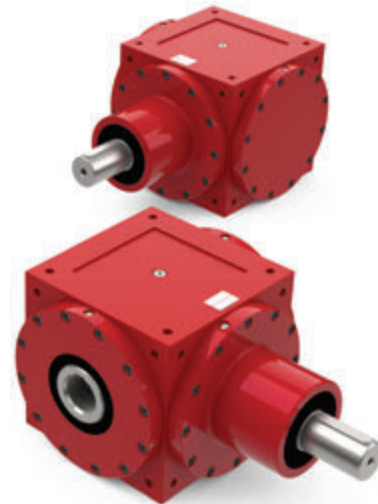

Tapped hole in end of each solid drive shaft - M16 x 38mm Deep

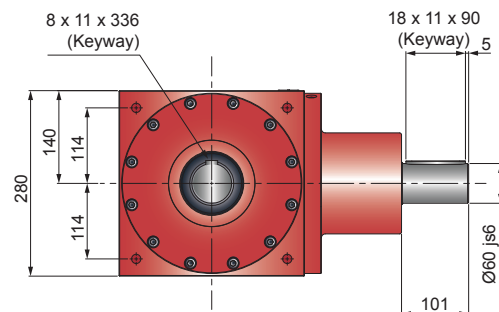

**Notes:**

1. All dimensions in mm unless otherwise stated
2. Dimensions subject to change without notice



### 3 Way Hollow Shaft

C400H30-10

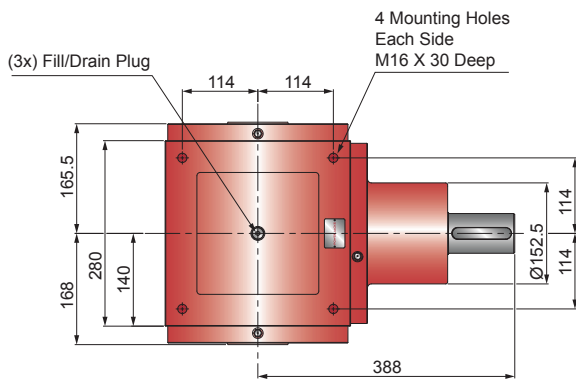

Tapped hole in end of each solid drive shaft - M16 x 38mm Deep

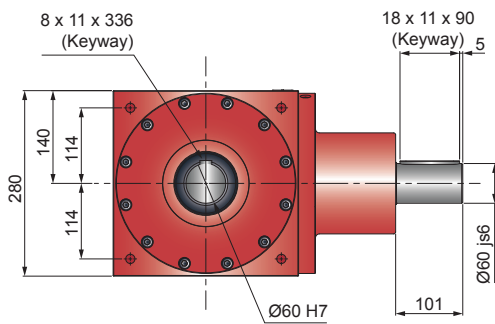

**Notes:**

1. All dimensions in mm unless otherwise stated
2. Dimensions subject to change without notice

### 4 Way Hollow Shaft

C400H40-10

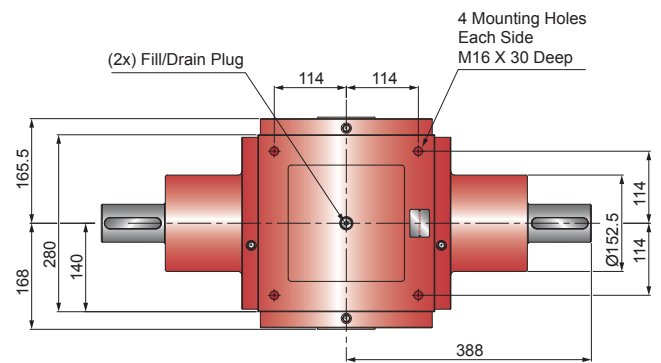

Tapped hole in end of each solid drive shaft - M16 x 38mm Deep

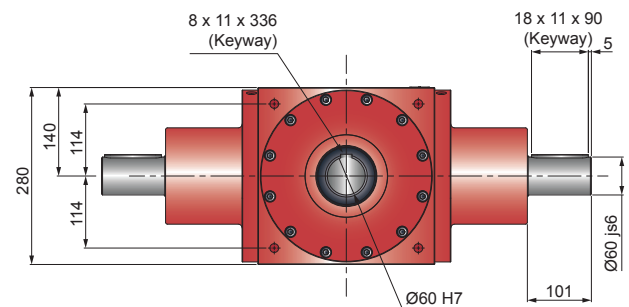

**Notes:**

1. All dimensions in mm unless otherwise stated
2. Dimensions subject to change without notice



## Performance

Series 42		
Torque (Nm)	Nominal#1	6195
	Max Running#2	7000
	Max Start-Up	10500
Input Speed	Max (rpm)	3000
Thermal Limit	Power (kW)	190
Backlash	arcmin	7 to 10
Efficiency	(%)	95% - 98%
Service Life	(hours)	>10000
Housing Material		SG Iron
Oil Quantity	Litres	7
	Pints	12.3
Weight (kg)	2 Way - 1:1 & 1.5:1	190
	3 Way - 1:1 & 1.5:1	197
	4 Way - 1:1 & 1.5:1	204



















### Notes:

#1 Nominal torque values at running speeds of 1500 rpm

#2 Maximum running torque value at speed of 10 rpm

Full detailed performance for each unit refer to page 16 & 17

## Accessories & Options

	Special Gear Ratio		Motor Flange
	Extended Drive Shaft		Limit Switches
	Drives		Light Weight Design
	Reinforced Shaft OR High Torque		Breather
	90° Breather		Mounting Feet
	Shaft Cover		Stainless Steel
	Submersible		Corrosion Protection
	Nuclear Rated		Food Grade
	Low Temperature		High Temperature

## 2 Way Solid Shaft

N420S20-10

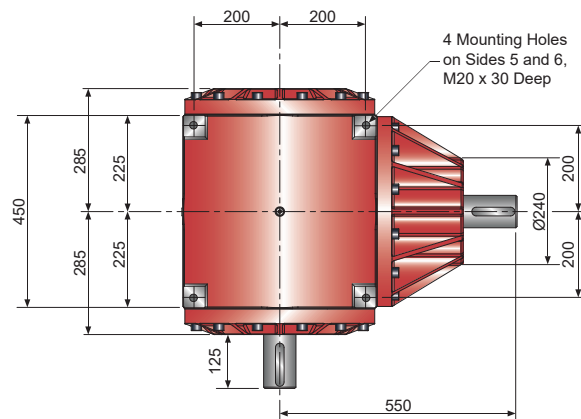

Tapped hole in end of each solid drive shaft - M16 x 38mm Deep

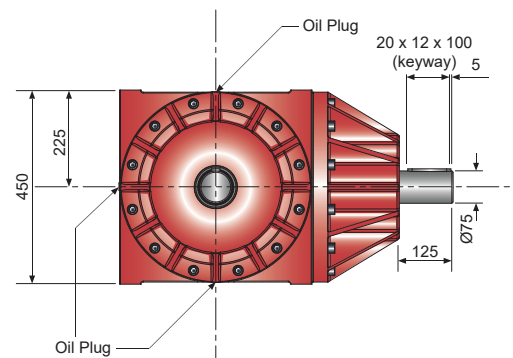

### Notes:

1. All dimensions in mm unless otherwise stated
2. Dimensions subject to change without notice

## 3 Way Solid Shaft

N420S30-10

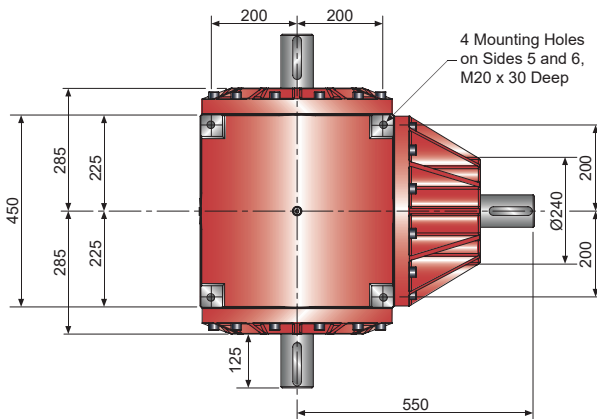

Tapped hole in end of each solid drive shaft - M16 x 38mm Deep

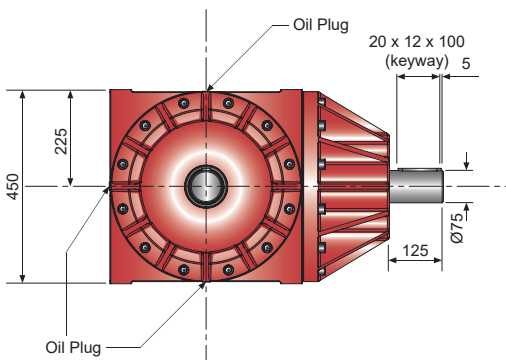

**Notes:**

1. All dimensions in mm unless otherwise stated
2. Dimensions subject to change without notice

## 4 Way Solid Shaft

N420S40-10

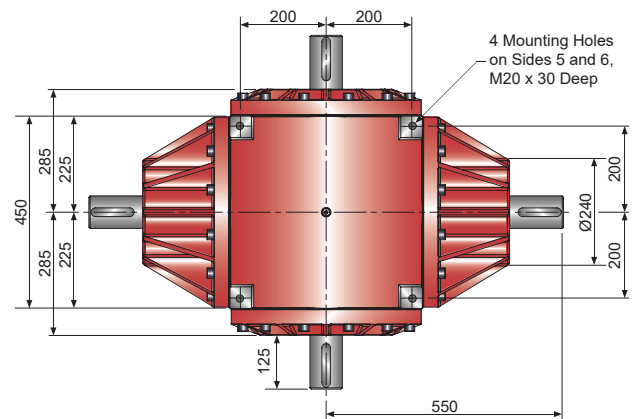

Tapped hole in end of each solid drive shaft - M16 x 38mm Deep

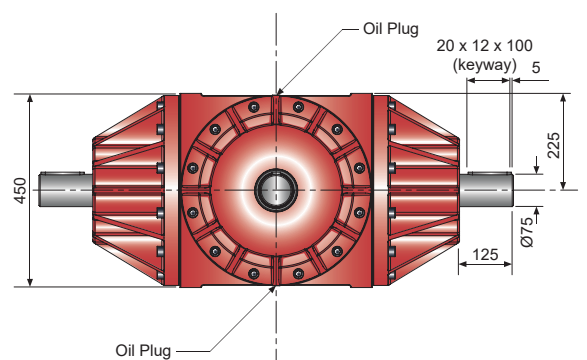

**Notes:**

1. All dimensions in mm unless otherwise stated
2. Dimensions subject to change without notice

## Performance

Series 42		
Torque (Nm)	Nominal#1	6195
	Max Running#2	7000
	Max Start-Up	10500
Input Speed	Max (rpm)	3000
Thermal Limit	Power (kW)	190
Backlash	arcmin	7 to 10
Efficiency	(%)	95% - 98%
Service Life	(hours)	>10000
Housing Material		SG Iron
Oil Quantity	Litres	7
	Pints	12.3
Weight (kg)	2 Way - 2:1 +	215
	3 Way - 2:1 +	223
	4 Way - 2:1 +	231



















### Notes:

#1 Nominal torque values at running speeds of 1500 rpm

#2 Maximum running torque value at speed of 10 rpm

Full detailed performance for each unit refer to page 16 & 17

## Accessories & Options

	Special Gear Ratio		Motor Flange
	Extended Drive Shaft		Limit Switches
	Drives		Light Weight Design
	Reinforced Shaft OR High Torque		Breather
	90° Breather		Mounting Feet
	Shaft Cover		Stainless Steel
	Submersible		Corrosion Protection
	Nuclear Rated		Food Grade
	Low Temperature		High Temperature

## 2 Way Solid Shaft

N420S20-20

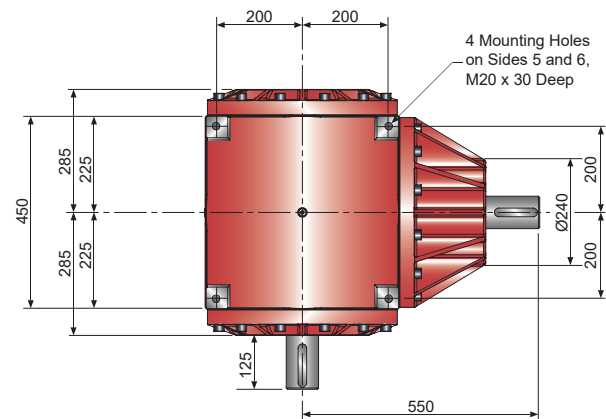

Tapped hole in end of each solid drive shaft - M16 x 38mm Deep

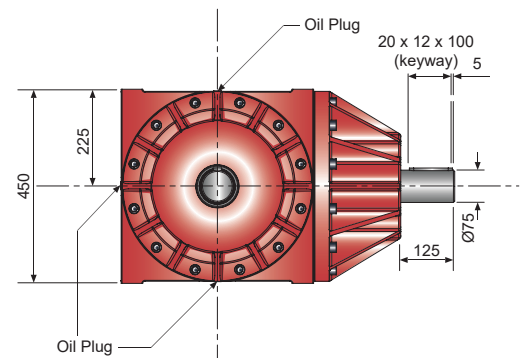

### Notes:

1. All dimensions in mm unless otherwise stated
2. Dimensions subject to change without notice

## 3 Way Solid Shaft

N420S30-20

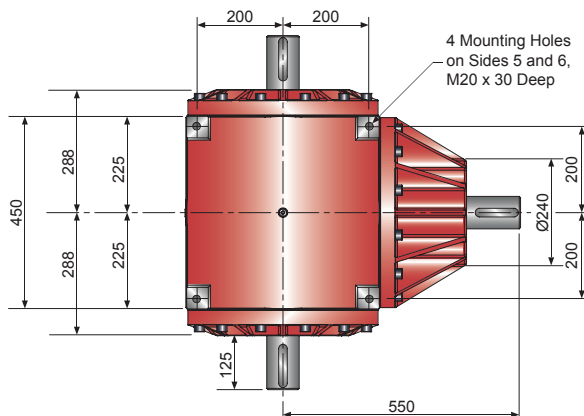

Tapped hole in end of each solid drive shaft - M16 x 38mm Deep

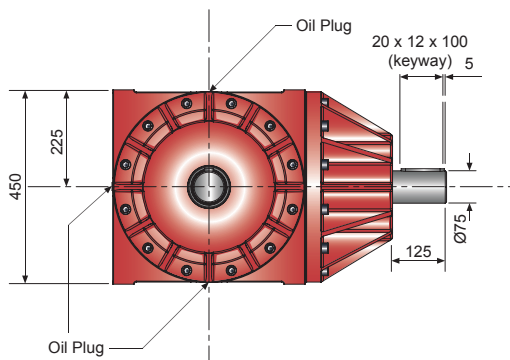

**Notes:**

1. All dimensions in mm unless otherwise stated
2. Dimensions subject to change without notice

## 4 Way Solid Shaft

N420S40-20

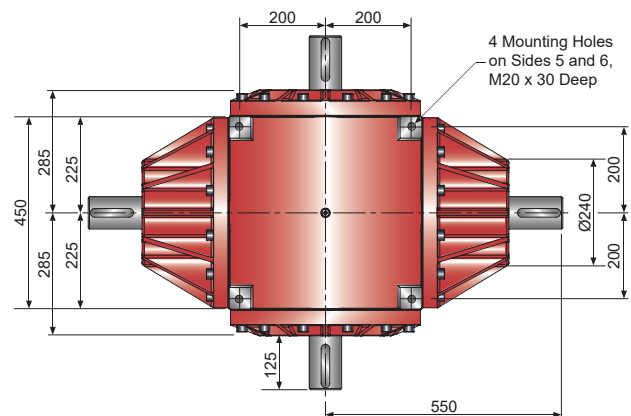

Tapped hole in end of each solid drive shaft - M16 x 38mm Deep

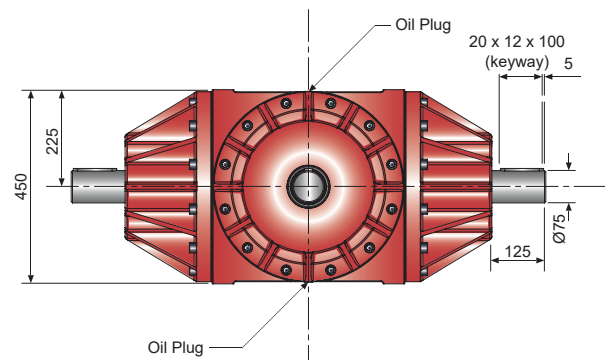

**Notes:**

1. All dimensions in mm unless otherwise stated
2. Dimensions subject to change without notice

### Performance

Series 42		
Torque (Nm)	Nominal#1	6195
	Max Running#2	7000
	Max Start-Up	10500
Input Speed	Max (rpm)	3000
Thermal Limit	Power (kW)	190
Backlash	arcmin	7 to 10
Efficiency	(%)	95% - 98%
Service Life	(hours)	>10000
Housing Material		SG Iron
Oil Quantity	Litres	7
	Pints	12.3
Weight (kg)	2 Way - 1:1 & 1.5:1	190
	2 Way - 2:1 +	215
	3 Way - 1:1 & 1.5:1	197
	3 Way - 2:1 +	223
	4 Way - 1:1 & 1.5:1	204
	4 Way - 2:1 +	231



















**Notes:**

#1 Nominal torque values at running speeds of 1500 rpm

#2 Maximum running torque value at speed of 10 rpm

Full detailed performance for each unit refer to page 16 & 17

### Accessories & Options

	Special Gear Ratio		Motor Flange
	Extended Drive Shaft		Limit Switches
	Drives		Light Weight Design
	Reinforced Shaft OR High Torque		Breather
	90° Breather		Mounting Feet
	Shaft Cover		Stainless Steel
	Submersible		Corrosion Protection
	Nuclear Rated		Food Grade
	Low Temperature		High Temperature

### 2 Way Hollow Shaft

N420H020-10

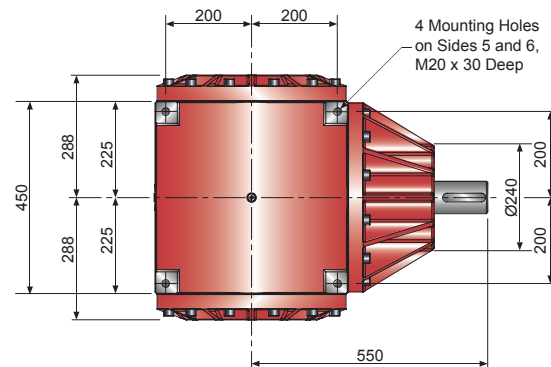

Tapped hole in end of each solid drive shaft - M16 x 38mm Deep

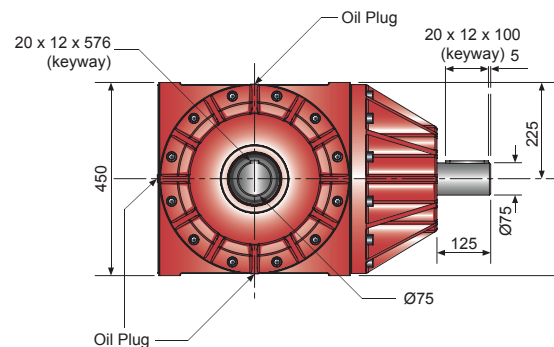

**Notes:**

1. All dimensions in mm unless otherwise stated
2. Dimensions subject to change without notice



### 3 Way Hollow Shaft

N420H030-10

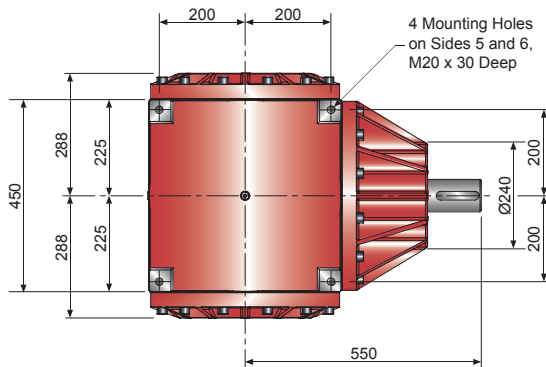

Tapped hole in end of each solid drive shaft - M16 x 38mm Deep

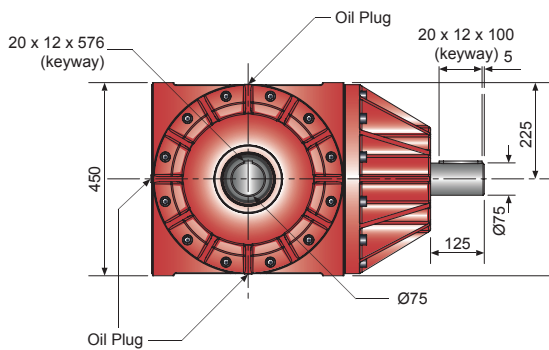

#### Notes:

1. All dimensions in mm unless otherwise stated
2. Dimensions subject to change without notice

### 4 Way Hollow Shaft

N420H040-10

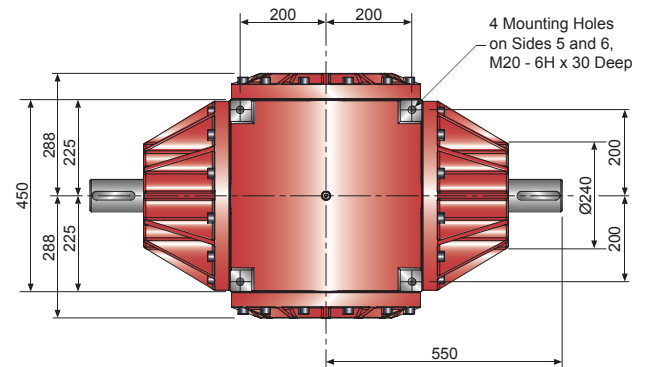

Tapped hole in end of each solid drive shaft - M16 x 38mm Deep

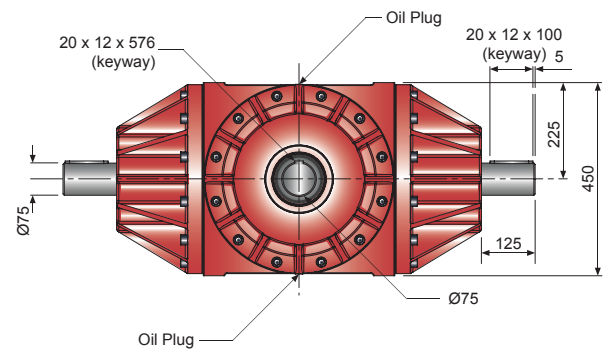

#### Notes:

1. All dimensions in mm unless otherwise stated
2. Dimensions subject to change without notice

# 10 Bevel Gearbox Range-C

## 252 Motor Adapters

POWERJACKS

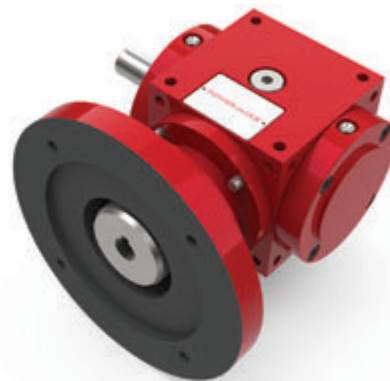
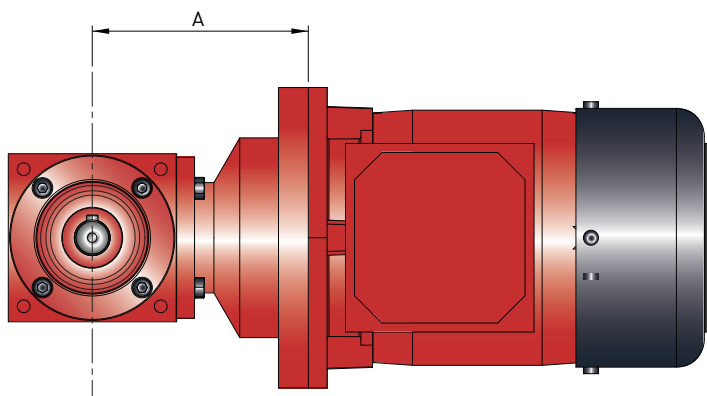

Motor frame Size B5 Flange	Gear unit Series	Gear Ratio	Dimension 'A'	Gear Unit Prefix for Product Code
71	35	All	115	A
80	35	All	115	B
90	37	All	130	C
100	37	1:1 & 1.5:1	130	D
100	37	2:1	140	D
112	37	1:1 & 1.5:1	130	D
112	37	2:1	140	D
112	38	All	190	D
132	38	All	190	E
132	39	All	220	E
160	38	1:1, 1.5:1 & 2:1	190	F
160	38	3:1 & 4:1	210	F
160	39	1:1, 1.5:1 & 2:1	220	F
160	39	3:1 & 4:1	240	F
180	39	1:1, 1.5:1 & 2:1	220	G
180	39	3:1 & 4:1	240	G
180	40	All	280	G
200	40	All	280	H
225 : 2 Pole	40	All	280	J
225 : 4-8 Pole	40	All	310	K
250 : 2 Pole	40	All	310	L

- Notes:
1. All standard motor adapters use a B5 IEC flange.
  2. All Flange dimensions conform to standard IEC electric motor details.
  3. NEMA flanges available on request.



## Extended Drive Shafts

---



For each gearbox size the drive shafts (input or output) can be extended in length for solid shaft or hollow shaft designs.

For an application these designs can:

- Eliminate the need for extra drives shafts.
- Reduce the number of couplings.
- Reduce the overall installation cost.
- Reduce the associated maintenance and spare parts inventory and cost.
- Allow the machine design to be fully optimised.

## Stainless Steel Bevel Gearboxes

---



Stainless steel gearboxes are recommended for use in applications which require one or more of the following properties:

- High corrosion resistance.
- Hygienic for food processing.
- Good chemical resistance.
- Resistance to fire & high temperatures.
- Strength at low temperatures.
- Stainless steel has good recycling options.
- Easy to clean surfaces.
- Non-magnetic options available.

All of which makes stainless steel gearboxes ideally suitable for industries such as marine, paper, chemical, food, beverage, nuclear, oil and gas.

## U-Series Underwater / Subsea Gearbox

The U-Series subsea bevel gearboxes are a proven and reliable technology for subsea drive solutions down to a depth of 3000m. They are used in a wide variety of underwater applications in the oil & gas and even the nuclear sector. Each submersible variant is tailored exactly to the customer application.

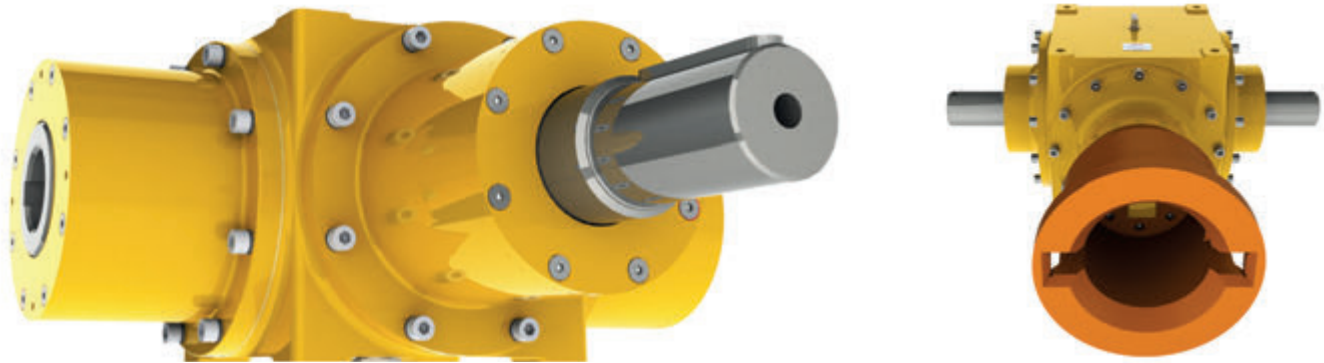

### Subsea Design Features

- Proven depth ratings up to 3000m subsea (deeper on request)
- Pressure compensated or flooded designs available
- Full stainless steel designs available
- Reinforced sealing
- Full range of anti-corrosion options
- ROV drive interfaces
- Low (-65°C) to High (+250°C) temperature solutions available
- Vibration and shock load resistant designs
- Full range of feedback devices for speed, position and rotation
- Special custom designs available to meet your exact requirements

### Standard Gearbox

- Six gearbox sizes
- 35, 37, 38, 39, 40, 42 Series
- Nine gearbox configurations
- Gear ratios: 1:1, 1.5:1, 2:1, 3:1, 4:1 as standard
- Special gear ratios available on request, e.g. 1.25:1
- Torque ratings up to 20000 Nm
- Option for reinforced shaft design for up to 300% higher torque transmission

### Reliable Spiral Bevel Gear

With a proven design already used in millions of gearboxes, the Precision Spiral Bevel Gears, with accurate gear mesh, deliver high torque with smooth and quiet transmission.



### Shaft Configurations

- 2, 3 or 4-way
- Solid or hollow shaft
- Special configurations available
- ROV torque receptacle integrated to gearbox drive
- ROV paddle adapter fitted to input drive shaft
- Motor adapter for direct connection of subsea motor to gearbox input
- Service life of 10,000 hours for all gearbox sizes
- Input speed up to 3,000 rpm maximum

### Gearbox Housing

A rugged compact design made from a highly durable SG iron as standard or stainless steel on request.

It provides a strong housing that firmly and accurately holds the gear set in a reservoir of quality lubricant suited to the demands of subsea work.

### Corrosion Protection

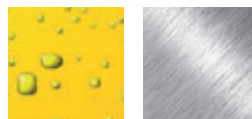

- To suit all economic needs
- Standard subsea paint finish
- Customer specified paint
- Plated finish
- Stainless steel

For more details request the U-Series brochure from Power Jacks or download a copy from [www.powerjacks.com](http://www.powerjacks.com)

## Design Possibilities / Designed For You

---

The Range-N bevel gearboxes are provided as a range of standard bevel gearboxes and as a range of engineered gearboxes. Each gearbox design can be altered to suit exact application requirements such as:

- Low weight designs.
- Long or short drive shafts.
- Keyless shafts.
- Shafts with threaded sections.
- Alternative shaft profiles e.g. hexagonal.
- Nuclear rated gearboxes.
- Food & beverage processing grade gearboxes.
- Special shaft sealing.
- Integrated or bolt on base flange.
- Extra mounting holes.
- Motor adapters for servo, hydraulic or air motors.
- Integrated limit switches.
- Protective shaft covers.
- High & low temperature rated designs.
- Alternative housing designs e.g. curved.
- High corrosion & chemical resistant designs.

Use Power Jacks engineering technology to bring your concept to reality.



# POWER JACKS OFFERS A WIDE RANGE OF REDUCTION GEARBOXES FOR SCREW JACK SYSTEM BUILDING

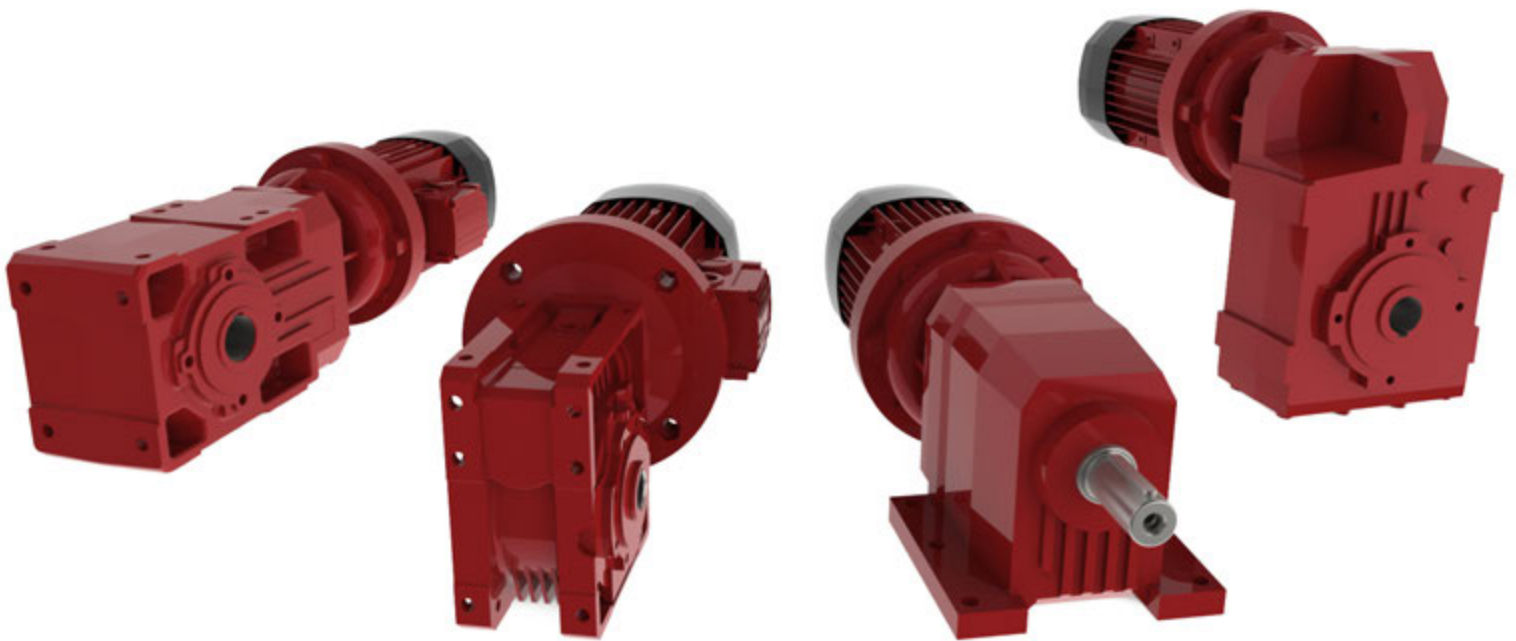

### A-series - Right Angled Helical Bevel Gearbox



Size	Torque [Nm]
A 05	100
A 10	150
A 20	250
A 30	410
A 35	600
A 41	850
A 50	1500
A 55	2000
A 60	2800
A 70	5000
A 80	8000
A 90	14000

**Torque Range**

100 Nm to 14000 Nm

**Power Rating**

0.22 kW to 150 kW (at 1400 rpm input)

**Gear Ratios**

5.4:1 to 1715:1

**Output**

- Foot and shaft mount - two bore options size
- Keyless shrink disc fitting
- Metric or Inch series solid output shaft
- Taper bushing
- Splined Hollow shaft to DIN 5480

**Input**

- IEC and NEMA motor adaptors
- Servo motor adapters
- Metric or inch series solid input shaft

**Main gear options**

- Backstop
- Reinforced bearings for higher overhung load capacity
- Reduced backlash
- Taconite seals

**AC Motors**

- Integral motors and brake motors
- IEC motors and brake motors
- Single and dual speed motors

**Main brake features**

- DC and AC supply
- Fast brake engage/disengage through electronically controlled AC/DC rectifiers.

**Main motor options**

- Thermistors and thermostat sensors
- Separate supply forced ventilation
- Line driver and push-pull incremental encoder

## C-series - In-Line Helical Gearbox



Size	Torque [Nm]
C 05	45
C 12	100
C 22	200
C 32	300
C 36	450
C 41	600
C 51	1000
C 61	1600
C 70	2300
C 80	4000
C 90	7200
C 100	12000

### Torque Range

45 Nm to 12000 Nm

### Power Rating

0.08 kW to 213 kW (at 1400 rpm input)

### Gear Ratios

2.6:1 to 1481:1

### Output

Foot and Flange mount  
Metric or inch series solid output shaft

### Input

IEC and NEMA motor adaptors  
Servo motor adaptors  
Metric or inch series solid input shaft

### AC Motors

Integral motors and brake motors  
IEC motors and brake motors  
Single and dual speed motors

### Main brake features

DC and AC supply  
Fast brake engage/disengage through electronically controlled AC/DC rectifiers.

### Main motor options

Thermistors and thermostat sensors  
Separate supply forced ventilation  
Line driver and push-pull incremental encoder



## F-series - Parallel Shaft Helical Gearbox

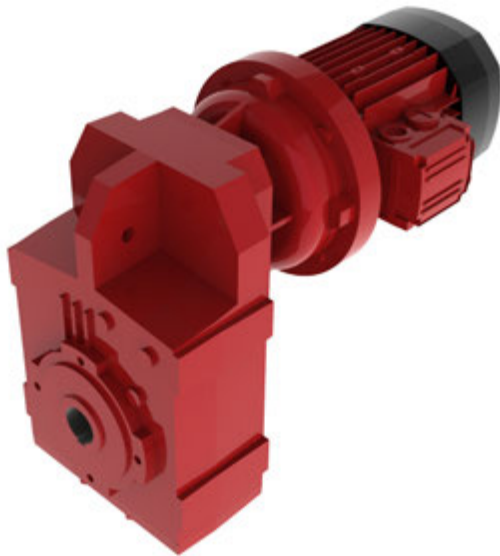

Size	Torque [Nm]
F 10	140
F 20	250
F 25	400
F 31	600
F 41	1100
F 51	1800
F 60	2900
F 70	5000
F 80	8000
F 90	14000

**Torque Range**

140 Nm to 14000 Nm

**Power Rating**

0.17 kW to 125 kW (at 1400 rpm input)

**Gear Ratios**

6.4:1 to 2099:1

**Output**

Keyed hollow shaft - two bore options per size

Keyless shrink disc fitting

Plug-in solid output shaft as an option

**Input**

IEC and NEMA motor adaptors

Servo motor adaptors

Metric or inch series solid input shaft

**AC Motors**

Integral motors and brake motors

IEC motors and brake motors

Single and dual speed motors

**Main brake features**

DC and AC supply

Fast brake engage/disengage through electronically controlled AC/DC rectifiers.

**Main motor options**

Thermistors and thermostat sensors

Separate supply forced ventilation

Line driver and push-pull incremental encoder

VF & W - Series - Worm Gearbox

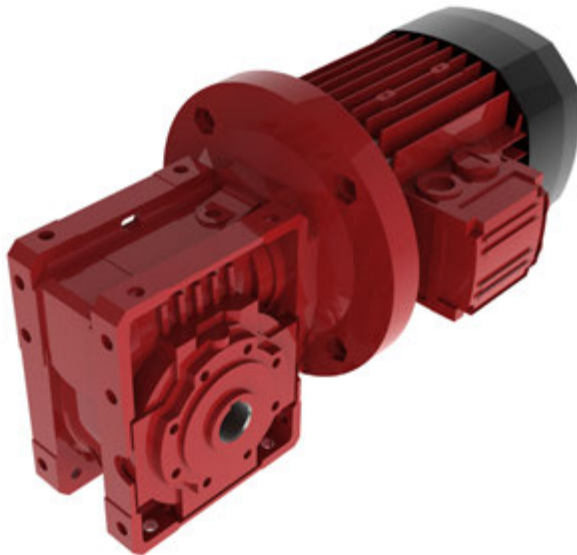

Size	Torque [Nm]
VF 27	13
VF 30	24
VF 44	55
VF 49	88
VF 63	190
VF 75	320
VF 86	440
VF 110	830
VF 130	1500
VF 150	2000
VF 185	3600
VF 210	5000
VF 250	7100

**Torque Range**

13 Nm to 71000 Nm

**Power Rating**

0.04 kW to 75 kW (at 1400 rpm input)

**Gear Ratios**

7:1 to 10000:1

**Output**

- Keyed hollow shaft
- Plug-in solid output shaft
- Torque limiter as an option

**Input**

- IEC motor adaptors
- Solid input shaft

**AC Motors**

- Integral motors and brake motors
- IEC motors and brake motors
- Single and dual speed motors

**Main brake features**

- DC and AC supply
- Fast brake engage/disengage through electronically controlled AC/DC rectifiers.

**Main motor options**

- Thermistors and thermostat sensors
- Separate supply forced ventilation
- Line driver and push-pull incremental encoder

POWER JACKS CAN SUPPLY  
ELECTRIC MOTORS FOR ALL  
APPLICATIONS WHETHER  
AC OR DC MOTORS ARE  
REQUIRED.

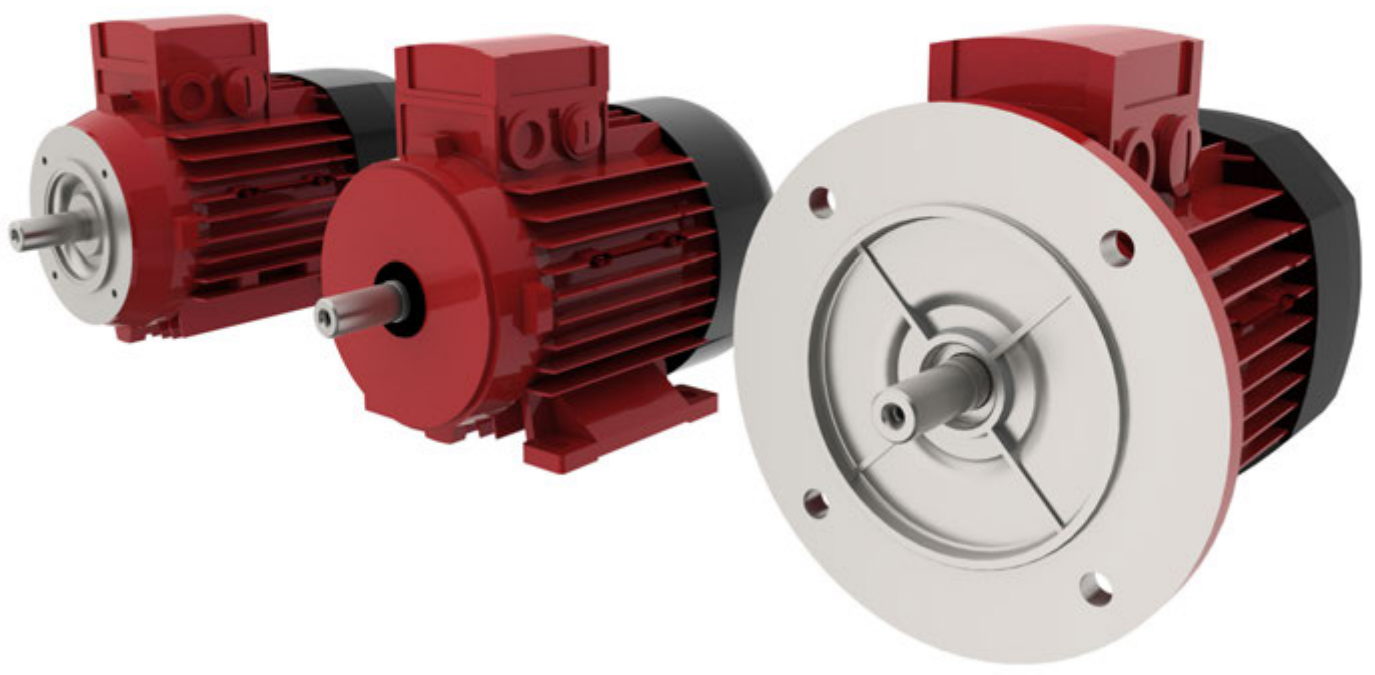

Power Jacks can supply electric motors for all applications whether AC or DC motors are required. Detailed in this section of the Design Guide are some of the most popular motors used in industrial applications.

## Ac Induction Motors

### Standard Specification

- 3 Phase, 50 Hz / 60Hz.
- Voltages:
  - IEC Frame 56 - 132
  - 230 / 400 V -  $\Delta$  / Y - 50 Hz (standard)
  - 400 / 690 V -  $\Delta$  / Y - 50 Hz (on request)
  - 460 V - Y - 60 Hz (standard)
  - IEC Frame 160 - 200
  - 400 / 690 V -  $\Delta$  / Y - 50 Hz (standard)
  - 460 V -  $\Delta$  - 60 Hz (standard)
- B3 Foot, B5 Flange and B14 Face Mounting. (or a combination).
- 2 Pole (3000 rpm)
- 4 Pole (1500 rpm)
- 6 Pole (1000 rpm)
- 8 Pole (750 rpm)
- IEC Frame Sizes 63 to 200.
- Enclosure IP55, TEFV.
- S1 Continuous rating.

### Optional

- Brake motors - AC or DC units.
- 2 and 8 Pole 3 phase AC motors.
- Single phase AC motors.
- DC motors - permanent magnet or servo.
- Cast Iron or Steel construction motors.
- High altitude and high temperature options.
- Integral AC inverter.
- Integral Incremental or Absolute encoder.
- Forced ventilation.
- Enclosures IP56 to IP68.
- Tropicalised motors.
- NEMA and Japanese standard units.
- Marine motors.
- Explosion proof motors, including ATEX motors.
- Anti-Condensation Heaters
- Thermistors
- H-Class Insulation
- Brake hand release
- Plug-in connectors
- Second output shaft.

### Features

- Standard Efficiency of IE1. Other efficiency ratings of IE2, IE3 and IE4 are available on request.
- Low noise levels.
- High power factors.
- High torque with smooth acceleration and low current.
- Aluminium construction for light weight and corrosion resistance.

## Brake Motor

The brake units are a single disc type mounted on the non-drive end-shield of the motor and can be either DC or AC types. They are spring applied electrically released units, which provide fail to safe operating characteristics such that on interruption, or failure of power supply, the brake will engage and arrest the load.

With DC brakes, the brake coil is fed via a rectifier in the motor terminal box and is automatically switched with the AC motor supply. AC brakes are connected directly to the motor terminals. They can however be separately energised from their own AC supply, in the case of inverter drives and/or where very fast brake operation is required.

The enclosure ratings for brake motors are IP54 as standard and IP55 on request. More enclosure ratings are available on request e.g. IP56.

Symbols	Units of Measure	Description
$\cos\phi$	-	Power Factor
$\eta$	-	Efficiency
$f_m$	-	Power adjusting factor
$l$	-	Cyclic duration factor
$I_N$	(A)	Rated current
$I_S$	(A)	Locked rotor current
$J_c$	[Kgm <sup>2</sup> ]	Load moment of inertia
$J_M$	[Kgm <sup>2</sup> ]	Moment of inertia
$K_c$	-	Torque factor
$K_d$	-	Load factor
$K_J$	-	Inertia factor
$M_A$	(Nm)	Mean breakaway torque
$M_B$	(Nm)	Brake torque
$M_N$	(Nm)	Rated torque
$M_L$	(Nm)	Counter-torque during acceleration
$M_S$	(Nm)	Starting torque

Symbols	Units of Measure	Description
$n$	(min <sup>-1</sup> )	Rated Speed
$P_B$	(W)	Power drawn by the brake at 20°C
$P_N$	(kW)	Motor rated power
$P_r$	(kW)	Required power
$t_1$	(ms)	Brake response time with one-way rectifier
$t_{1S}$	(ms)	Brake response time with electronic-controlled rectifier
$t_2$	(ms)	Brake reaction time with a.c. disconnect
$t_{2C}$	(ms)	Brake reaction time with a.c. disconnect
$t_a$	°C	Ambient temperature
$t_f$	(min)	Work time constant load
$t_r$	(min)	Rest Time
$W$	(J)	Braking work between service interval
$W_{MAX}$	(J)	Maximum brake work for each braking
$Z$	(1/h)	Permissible starting frequency, loaded
$Z_0$	(1/h)	Max. permissible unloaded starting frequency (I=50%)

#### Motor Rating - 2 Pole Motors (3000 rpm)

3000 min <sup>-1</sup> - S1															50Hz											
2P	P <sub>n</sub> kW	n min <sup>-1</sup>	M <sub>n</sub> Nm	IE1	η (100%) %	η (75%) %	η (50%) %	cosφ	I <sub>n</sub> 400V A	I <sub>s</sub> In	M <sub>s</sub> Mn	M <sub>a</sub> Mn	J <sub>x</sub> 10 <sup>-4</sup> kgm <sup>2</sup>	1M B5 Kg	d.c. brake					a.c. brake						
															FD					FA						
															Type	Mb Nm	Z <sub>0</sub> 1/h	J <sub>x</sub> 10 <sup>-4</sup> kgm <sup>2</sup>	1M B5 Kg	Type	Mb Nm	Z <sub>0</sub> 1/h	J <sub>x</sub> 10 <sup>-4</sup> kgm <sup>2</sup>	1M B5 Kg		
0.18	BN 63A	2	2730	0.63	N/A	56.9	51.9	0.77	0.56	3.0	2.1	2.0	2.0	3.5	FD-02	1.75	3900	4800	2.6	5.2	FA-02	1.75	4800	2.6	5.0	
0.25	BN 63B	2	2740	0.87	N/A	64.8	64.8	0.76	0.72	3.3	2.3	2.3	2.3	3.9	FD-02	1.75	3900	4800	3.0	5.6	FA-02	1.75	4800	3.0	5.4	
0.37	BN 63C	2	2800	1.26	N/A	69.1	66.8	0.78	0.99	3.9	2.6	2.6	3.3	5.1	FD-02	3.5	3600	4500	3.9	6.8	FA-02	3.5	4500	3.9	6.6	
0.37	BN 71A	2	2820	1.25	N/A	73.8	70.6	0.76	0.95	4.8	2.8	2.6	3.5	5.4	FD-03	3.5	3000	4100	4.6	8.1	FA-03	3.5	4200	4.6	7.8	
0.55	BN 71B	2	2820	1.86	N/A	75.8	74.8	0.76	1.37	5.0	2.9	2.8	4.1	6.2	FD-03	5	2900	4200	5.3	8.9	FA-03	5	4200	5.3	8.6	
0.75	BN 71C	2	2810	2.6	N/A	76.6	76.2	0.76	1.86	5.1	3.1	2.8	5.0	7.3	FD-03	5	1900	3300	6.1	10.0	FA-03	5	3600	6.1	9.7	
0.75	BN 80A	2	2810	2.6	✓	76.2	75.5	0.81	1.75	4.8	2.6	2.6	7.8	8.6	FD-04	5	1700	3200	9.4	12.5	FA-04	5	3200	9.4	12.4	
1.1	BN 80B	2	2800	3.8	✓	76.4	76.2	0.81	2.57	4.8	2.8	2.8	9.0	9.5	FD-04	10	1500	3000	13.4	13.4	FA-04	10	3000	10.6	13.3	
1.5	BN 90C	2	2800	5.1	✓	79.1	77.2	0.81	3.4	4.9	2.7	2.8	11.4	11.3	FD-04	15	1300	2600	15.2	15.2	FA-04	15	2600	13.0	15.1	
1.5	BN 90SA	2	2870	5.0	✓	82.0	81.5	0.80	3.4	5.9	2.7	2.6	12.5	12.3	FD-14	15	900	2200	14.1	16.5	FA-14	15	2200	14.1	16.4	
1.85	BN 90SB	2	2880	6.1	✓	82.5	82.0	0.80	4.0	6.2	2.9	2.6	16.7	14	FD-14	15	900	2200	18.3	18.2	FA-14	15	2200	18.3	18.1	
2.2	BN 90L	2	2880	7.3	✓	82.7	82.1	0.80	4.8	6.3	2.9	2.7	16.7	14	FD-05	26	900	2200	21	20	FA-05	26	2200	21	20.7	
3	BN 100L	2	2860	10.0	✓	81.5	81.3	0.79	6.7	5.6	2.6	2.6	31	20	FD-15	26	700	1600	35	26	FA-15	26	1600	35	27	
4	BN 100LB	2	2870	13.3	✓	83.1	83.0	0.80	6.7	5.8	2.7	2.5	39	23	FD-15	40	450	900	43	29	FA-15	40	1000	43	30	
4	BN 112M	2	2900	13.2	✓	85.5	84.5	0.82	8.2	6.9	3.0	2.9	57	28	FD-06S	40	-	950	66	39	FA-06S	40	950	66	40	
5.5	BN 132SA	2	2890	18.2	✓	84.7	84.5	0.84	11.2	5.9	2.6	2.2	101	35	FD-06	50	-	600	112	48	FA-06	50	600	112	49	
7.5	BN 132SB	2	2900	25	✓	86.5	86.3	0.85	14.7	6.4	2.6	2.2	145	42	FD-06	50	-	550	154	55	FA-06	50	550	154	56	
9.2	BN 132M	2	2930	30	✓	87.0	86.5	0.86	17.7	6.7	2.8	2.3	178	53	FD-56	75	-	430	189	66	FA-06	75	430	189	67	
11	BN 160MR	2	2920	36	✓	87.6	87.0	0.88	20.6	6.9	2.9	2.5	210	65												
15	BN 160MB	2	2930	49	✓	89.6	89.4	0.86	28.1	7.1	2.6	2.3	340	84												
18.5	BN 160L	2	2930	60	✓	90.4	90.1	0.86	34	7.6	2.7	2.3	420	97												
22	BN 180M	2	2930	72	✓	89.9	89.7	0.88	40	7.8	2.6	2.4	490	109												
30	BN 200LA	2	2930	98	✓	90.7	90.1	0.89	54	7.8	2.7	2.9	770	140												





#### Motor Rating - 6 Pole Motors (1000 rpm)

6P		1000 min <sup>-1</sup> - S1														50Hz														
		d.c. brake														a.c. brake														
		P <sub>n</sub> kW	n min <sup>-1</sup>	M <sub>n</sub> Nm	IE1	η (100%) %	η (75%) %	η (50%) %	cosφ	I <sub>n</sub> 400V A	I <sub>s</sub> I <sub>n</sub>	M <sub>s</sub> M <sub>n</sub>	M <sub>a</sub> M <sub>n</sub>	J <sub>x</sub> 10 <sup>-4</sup> kgm <sup>2</sup>	1M B5 Kg	FD		FA			1M B5 Kg	J <sub>x</sub> 10 <sup>-4</sup> kgm <sup>2</sup>	Z <sub>0</sub> 1/h	Mb Nm	Type	Mb Nm	Z <sub>0</sub> 1/h	J <sub>x</sub> 10 <sup>-4</sup> kgm <sup>2</sup>	1M B5 Kg	
NB	SB															NB	SB	Type	NB	SB										
0.09	BN 63A	6	880	0.98	N/A	41.0	32.9	0.53	0.60	2.1	2.1	1.8	3.4	4.6	4.6	9000	14000	4.0	6.3	14000	4.0	4.0	4.0	3.5	FD-02	3.5	14000	4.0	6.1	6.1
0.12	BN 63B	6	870	1.32	N/A	45.0	41.8	0.53	0.64	2.1	1.9	1.7	3.7	4.9	9000	14000	4.3	6.6	14000	4.3	4.3	4.3	3.5	FD-02	3.5	14000	4.3	6.4	6.4	
0.18	BN 71A	6	900	1.91	N/A	55.0	51.0	0.69	0.68	2.6	1.9	1.7	8.4	5.5	8100	13500	9.5	8.2	13500	9.5	9.5	9.5	5.0	FD-03	5.0	13500	9.5	7.9	7.9	
0.25	BN 71B	6	900	2.70	N/A	62.0	58.5	0.71	0.82	2.6	1.9	1.7	10.9	6.7	7800	13000	12	9.4	13000	12	12	12	5.0	FD-03	5.0	13000	12	9.1	9.1	
0.37	BN 71C	6	910	3.9	N/A	66.0	60.0	0.69	1.17	3.0	2.4	2.0	12.9	7.7	5100	9500	14	10.4	9500	14	14	14	7.5	FD-03	7.5	9500	14	10.1	10.1	
0.37	BN 80A	6	910	3.9	N/A	68.0	67.4	0.68	1.15	3.2	2.2	2.0	21	9.9	5200	8500	23	13.8	8500	23	23	23	10	FD-04	10	8500	23	13.7	13.7	
0.55	BN 80B	6	920	5.7	N/A	70.0	69.8	0.68	1.67	3.9	2.6	2.2	25	11.3	4800	7200	27	15.2	7200	27	27	27	15	FD-04	15	7200	27	15.1	15.1	
0.75	BN 80C	6	920	7.8	✓	70.0	70.0	0.65	2.38	3.8	2.5	2.2	28	12.2	3400	6400	30	16.1	6400	30	30	30	15	FD-04	15	6400	30	16.0	16.0	
0.75	BN 90S	6	920	7.8	✓	70.0	69.0	0.68	2.27	3.8	2.4	2.2	26	12.6	3400	6500	28	16.8	6500	28	28	28	15	FD-14	15	6500	28	16.7	16.7	
1.1	BN 80B	6	920	11.4	✓	72.9	72.6	0.69		3.9	2.3	2.0	33	15	2700	5000	37	21	5000	37	37	37	26	FD-01	26	7800	37	22	22	
1.5	BN 100LA	6	940	15.2	✓	75.2	74.2	0.72	4.0	4.1	2.1	2.0	82	22	1900	4100	86	28	4100	86	86	86	40	FD-15	40	4100	86	29	29	
1.85	BN 100LB	6	930	19.0	✓	76.6	72.8	0.73	4.8	4.6	2.1	2.0	95	24	1700	3600	99	30	3600	99	99	99	40	FD-15	40	3600	99	31	31	
2.2	BN 112M	6	940	22	✓	78.5	79.0	0.81	5.5	4.8	2.2	2.0	168	32	2100	4200	177	42	4200	177	177	177	60	FD-06S	60	2100	177	44	44	
3	BN 132S	6	940	30	✓	79.7	77.0	0.76	7.1	5.1	1.9	1.8	216	36	1400	2260	226	49	2260	226	226	226	75	FD-06	75	1400	226	50	50	
4	BN 132MA	6	950	40	✓	81.4	81.5	0.77	9.2	5.5	2.0	1.8	295	45	1200	3050	305	58	3050	305	305	305	100	FD-07	100	1200	305	63	63	
5.5	BN 132MB	6	945	56	✓	83.1	80.9	0.78	12.2	6.1	2.1	1.9	383	56	1050	4060	406	72	4060	406	406	406	150	FD-07	150	1050	406	74	74	
11	BN 160M	6	955	75	✓	85.0	84.8	0.81	15.7	5.9	2.2	2.0	740	83	900	8150	815	112	8150	815	815	815	170	FD-08	170	900	815	113	113	
15	BN 160L	6	960	109	✓	86.4	86.5	0.81	22.7	6.6	2.5	2.3	970	103	800	10450	1045	133	10450	1045	1045	1045	200	FD-08	200	800	1045	133	133	
18.5	BN 180L	6	970	148	✓	87.7	88.0	0.82	30	6.2	2.0	2.4	1550	130	600	17500	1750	170												
30	BN 200LA	6	960	184	✓	88.6	88.0	0.81	37	5.9	2.0	2.3	1700	145	450	19000	1900	185												

Motor Rating - 8 Pole Motors (750 rpm)

8P		750 min <sup>-1</sup> - S1														50Hz						
		d.c. brake														a.c. brake						
		P <sub>n</sub> kW	n min <sup>-1</sup>	M <sub>n</sub> Nm	η %	cosφp	I <sub>n</sub> 400V A	I <sub>s</sub> I <sub>n</sub>	M <sub>s</sub> M <sub>n</sub>	M <sub>a</sub> M <sub>n</sub>	J <sub>r,x</sub> 10 <sup>-4</sup> kgm <sup>2</sup>	1M B5 Kg	Type	Mb Nm	Z <sub>0</sub> 1/h		J <sub>r,x</sub> 10 <sup>-4</sup> kgm <sup>2</sup>	1M B5 Kg	Type	Mb Nm	Z <sub>0</sub> 1/h	J <sub>r,x</sub> 10 <sup>-4</sup> kgm <sup>2</sup>
NB	SB														FA	FA						
0.09	8	680	1.26	47	0.59	0.47	2.3	2.4	2.3	10.9	6.7	FD-03	3.5	9000	16000	12.0	9.4	FD-03	3.5	16000	12.0	9.1
0.12	8	680	1.69	51	0.59	0.58	2.1	2.3	12.9	7.7	FD-03	5.0	9000	16000	14.0	10.4	FD-03	5.0	16000	14.0	10.1	
0.18	8	690	2.49	51	0.60	0.85	2.4	2.2	15	8.2	FD-04	5.0	6500	11000	16.6	12.1	FD-04	5.0	11000	16.6	12.0	
0.25	8	680	3.51	54	0.63	1.06	2.4	2.0	1.9	20	9.9	FD-04	10.0	6000	10000	22	13.8	FD-04	10.0	10000	22	13.7
0.37	8	675	5.2	58	0.60	1.53	2.6	2.3	2.1	26	12.6	FD-14	15.0	4800	7500	28	16.8	FD-14	15.0	7500	28	16.7
0.55	8	670	7.8	62	0.60	2.13	2.6	2.2	2.0	33	15	FD-05	26	4000	6400	37	21	FD-05	26	6400	37	22
0.75	8	700	10.2	68	0.63	2.53	3.4	1.9	1.7	82	22	FD-15	26	2800	4800	86	28	FD-15	26	4800	86	29
1.1	8	700	15.0	68	0.64	3.65	3.2	1.7	1.7	95	24	FD-15	40	2500	4000	99	30	FD-15	40	4000	99	31
1.5	8	710	20.2	71	0.66	4.6	3.7	1.8	1.9	168	32	FD-06S	60	-	3000	177	42	FD-06S	60	3000	177	44
2.2	8	710	29.6	75	0.66	6.4	3.8	1.8	2.0	295	45	FD-56	75	-	2300	305	58	FD-06	75	2300	305	56
3	8	710	40.4	76	0.69	8.3	3.9	1.6	1.8	370	53	FD-06	100	-	1900	394	69	FD-07	100	1900	406	74

#### Motor Dimensions - Standard - B3 Foot Mount

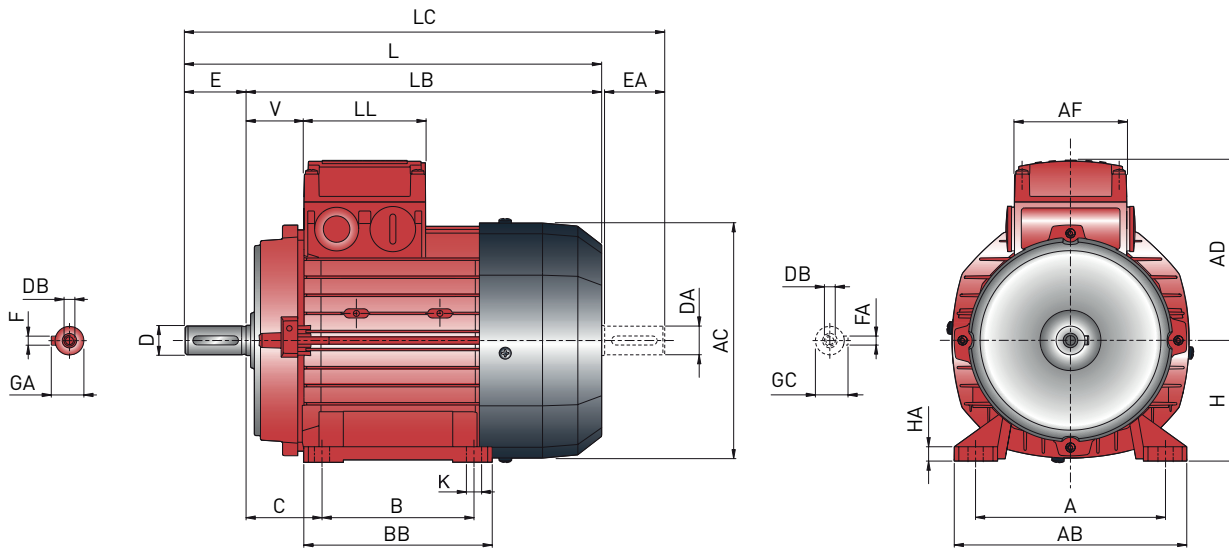

FRAME SIZE	SHAFT					HOUSING						MOTOR									
	D DA	E EA	DB	GA GC	F FA	B	A	HA	BB	AB	K	C	HC	AC	L	LB	LC	AD	AF	LL	V
BN 63	11	23	M4	12	4	80	100	8	96	120	7	40	63	121	207	184	232	95	74	80	30
BN 71	14	30	M5	16	5	90	112	8	112	135		45	71	138	249	219	281	108			
BN 80	19	40	M6	21.5	6	100	125	8	124	153	10	50	80	156	273	233	315	119	98	98	38
BN 90S	24	50	M8	27	8		140	8	155	174		56	90	176	326	276	378	133			
BN 90L						125	192	63	100	195	366	306	429	142	50	80	156	273	233	315	119
BN 100	28	60	M10	31	8	140	160	10	175	224	12	70	112	219	385	325	448	157	118	118	52
BN 112							190					224	70	112	219	385	325	448			
BN 132S	38	80	M12	41	10	178	216	12	218	254	12	89	132	260	493	413	576	193	118	118	58
BN 132M							216					12	218	254	89	132	260	493	413	576	193
BN 160M	42 38 (1)	110 80 (1)	M16 M12 (1)	45 41 (1)	12 10 (1)	210 254	254	25	319	319	14.5	108	160	310	596	486	680	245	187	187	51
BN 160L															640	530	724				
BN 180L	48 42 (1)	110 110 (1)	M16 M16 (1)	51.5 45 (1)	14 12 (1)	279	279	26	329	359	14	121	180	348	708	598	823	261	187	187	52
BN 200L															55 42 (1)	M20 M16 (1)	59 45 (1)				

**Note**

1. These values refer to the rear shaft end.

Motor Dimensions - Standard - B5 Flange Mount

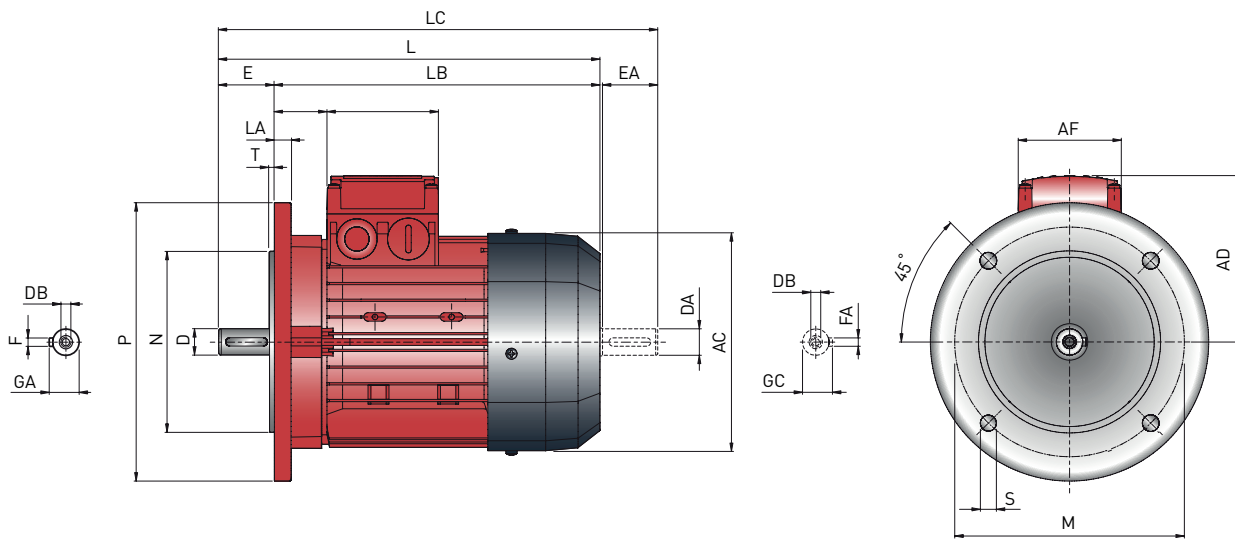

FRAME SIZE	SHAFT					FLANGE						MOTOR							
	D DA	E EA	DB	GA GC	F FA	M	N	P	S	T	LA	AC	L	LB	LC	AD	AF	LL	V
BN 56	9	20	M3	10.2	3	100	80	120	7	3	8	110	185	165	207	91	74	80	34
BN 63	11	23	M4	12.5	4	115	95	140	9.5		10	121	207	184	232	95			26
BN 71	14	30	M5	16	5	130	110	160				138	249	219	281	108			37
BN 80	19	40	M6	21.5	6	165	130	200	11.5	3.5	11.5	156	274	234	315	119	98	98	38
BN 90	24	50	M8	27	8							176	326	276	378	133			44
BN 100	28	60	M10	31	8	125	180	250	14	4	14	63	367	307	429	142	98	98	50
BN 112						15	219	385			325	448	157	52					
BN 132	38	80	M12	41	10	265	230	300	18.5	5	20	258	493	413	576	193	118	118	58
BN 160 MR	42 38 (1)	110 80 (1)	M16 M12 (1)	45 41 (1)	12 10 (1)	300	250	350			18.5		5	15	562				452
BN 160 M												310			596	486	680	245	51
BN 160 L									310	640		530			724	187	187		
BN 180 M	48 38 (1)	110 110 (1)	M16 M12 (1)	51.5 41 (1)	14 10 (1)	350	300	400	18.5	5	18	348	708	598	823	261	187	187	52
BN 180 L	48 42 (1)		M16 M16 (1)	51.5 45 (1)	14 12 (1)								722	612	837				66
BN 200 L	55 42 (1)		M20 M16 (1)	59 45 (1)	16 12 (1)								66						

Note

1. These values refer to the rear shaft end.

### Motor Dimensions - Standard - B14 Face Mount

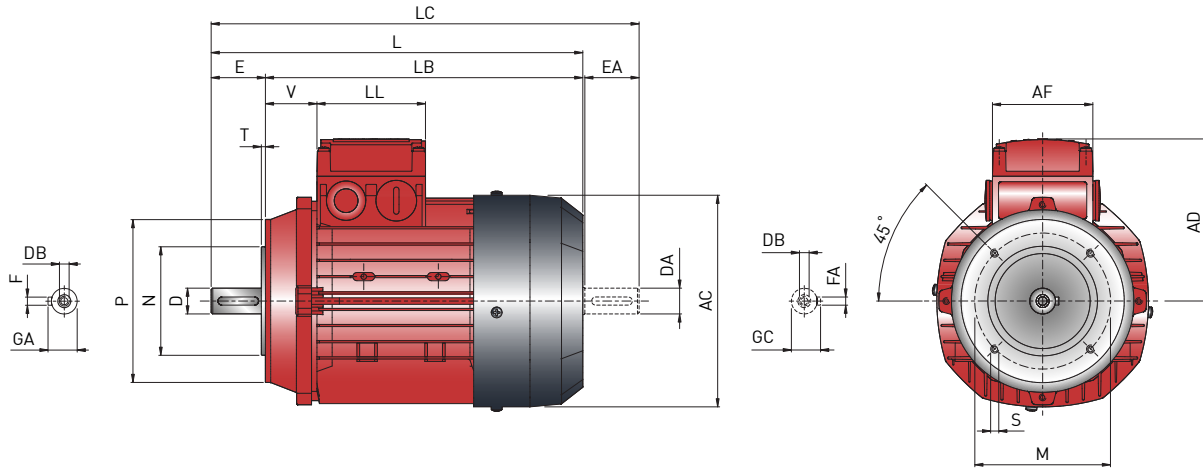

FRAME SIZE	SHAFT					FLANGE					MOTOR							
	D DA	E EA	DB	GA GC	F FA	M	N	P	S	T	AC	L	LB	LC	AD	AF	LL	V
BN 56	9	20	M3	10.2	3	65	50	80	M5	2.5	110	185	165	207	91	74	80	34
BN 63	11	23	M4	12.5	4	75	60	90			121	207	184	232	95			26
BN 71	14	30	M5	16	5	85	70	105	M6		138	249	219	281	108			37
BN 80	19	40	M6	21.5	6	100	105	120		3	156	274	234	315	119	38		
BN 90	24	50	M8	27	8	115	120	140	M8		3.5	176	326	276	378	133	98	98
BN 100	28	60	M10	31		130	110	160		195		367	307	429	142	50		
BN 112						219	385	325	448	157		52						
BN 132	38	80	M12	41	10	165	130	200	M10	4	258	493	413	576	193	118	118	58

Motor Dimensions - Brake Motor - DC Brake - B3 Foot Mount

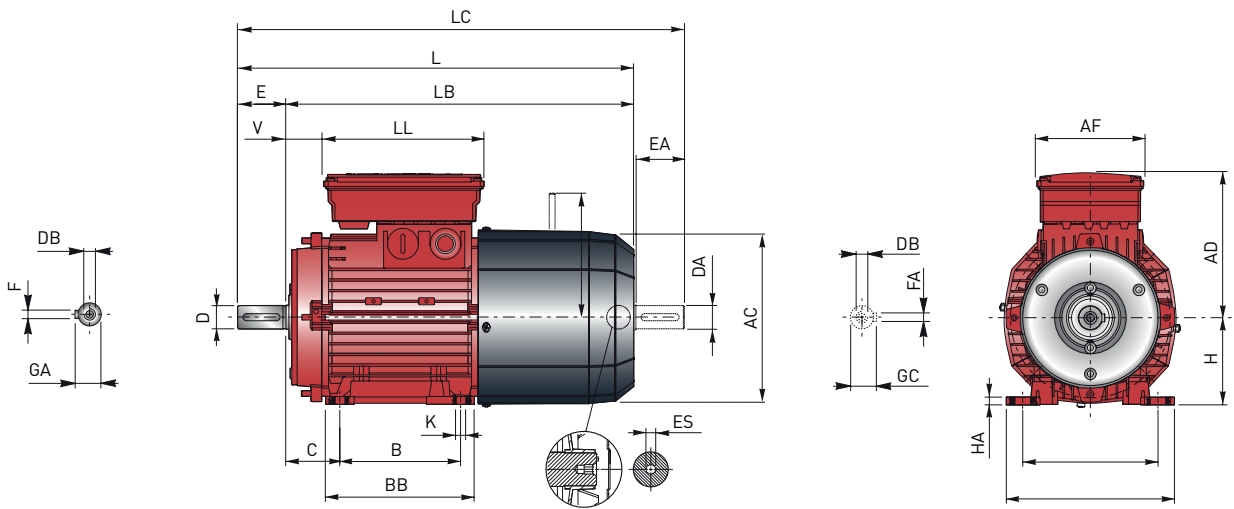

FRAME SIZE	SHAFT					HOUSING						MOTOR											
	D DA	E EA	DB	GA GC	F FA	B	A	HA	BB	AB	K	C	H	AC	L	LB	LC	AD	AF	LL	V	R	S
BN 63	11	23	M4	12	4	80	100	8	96	120	7	40	63	121	272	249	297	122	98	133	14	96	5
BN 71	14	30	M5	16	5	90	112	8	112	135		45	71	138	310	280	342	135			25	103	
BN 80	19	40	M6	21.5	6	100	125	8	124	153	10	50	80	156	346	306	388	146	110	165	41	129	6
BN 90S	24	50	M8	27	8		140	8	155	174		56	90	176	409	359	461	149			15	39	
BN 90L						125	10	175	224	70	112	219	484	424	547	173	62	73	199				
BN 100	28	60	M10	31	8	140	160	10	175	192	12	63	100	195	458	398	521	158	140	188	46	204 (2)	-
BN 112							190					224	70	112	219	484	424	547			173	62	
BN 132S	38	80	M12	41	10	178	216	12	218	254	14.5	89	132	260	603	523	686	210	187	187	46	305	-
BN 132M							254					25	319	108	160	310	736	626			820	245	
BN 160M	42	110	M16	45	12	210	254	25	264	319	14	108	160	310	780	670	884	245	187	187	52	305	-
BN 160L	38 (1)	80 (1)	M12 (1)	41 (1)	10 (1)	254															254		
BN 180L	48	110	M16	51.5	14	279	279	26	329	359	18	133	180	200	878	768	993	261	187	187	52	305	-
BN 200L	42 (1)		M20	45 (1)	12 (1)	305	318		355	398											18		

Note

1. These values refer to the rear shaft end.
2. For FD07 high torque brake value R=226 (consult Power Jacks for more details).



#### Motor Dimensions - Brake Motor - DC Brake - B5 Flange Mount

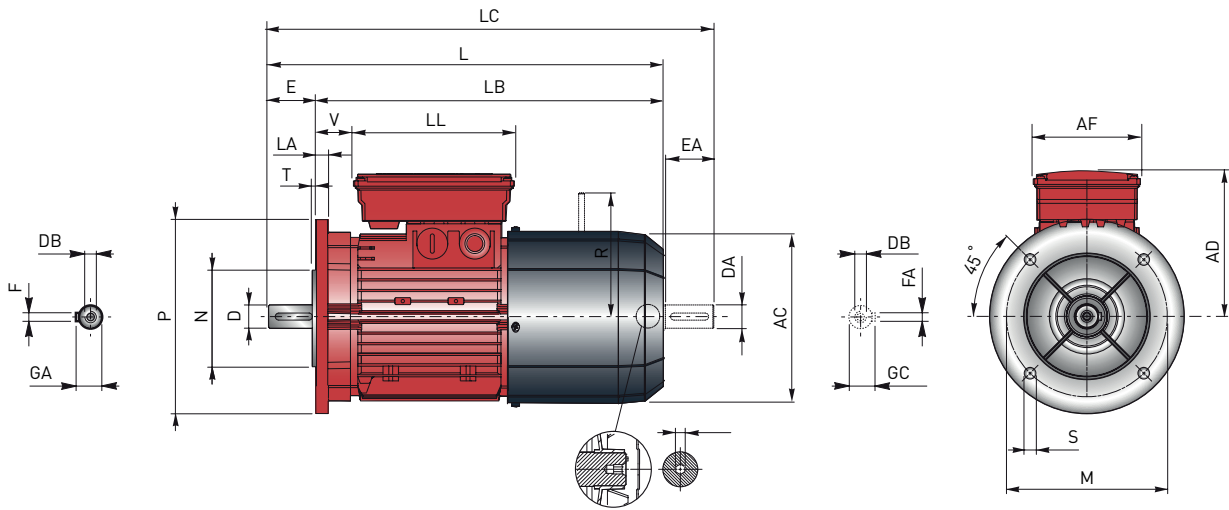

FRAME SIZE	SHAFT					FLANGE						MOTOR									
	D DA	E EA	DB	GA GC	F FA	M	N	P	S	T	LA	AC	L	LB	LC	AD	AF	LL	V	R	ES
BN 63	11	23	M4	12	4	115	95	140	9.5	3	10	121	272	249	297	122	98	133	14	96	5
BN 71	14	30	M5	16	5	130	110	160	9.5	3.5		138	310	280	342	135			25	103	
BN 80	19	40	M6	21.5	6	165	130	200	11.5		11.5	156	346	156	388	146	41	129			
BN 90S	24	50	M8	27	8					215		215	215	14	4	176	409	176	461	149	165
BN 90L						146	160														
BN 100	28	60	M10	31	10	265	230	300	14	4	14	195	458	195	521	158	165	62	6		
BN 112											15	219	484	219	547	173	165	73		199	
BN 132	38	80	M12	41	10	300	250	350	18.5	5	20	258	603	523	686	210	140	188	46	204 (2)	
BN 160MR	42	110	M16	45	12						672	562	755	161	226						
BN 160M	38 (1)	80 (1)	M12 (1)	M41 (1)	10 (1)	300	250	350	18.5	5	15	310	736	626	820	245	187	187	51	266	
BN 180M	48	110	M16	51.5	14								780	670	864	187			187	64	305
BN 180L	48	110	M16	51.5	14	350	300	400	18.5	18	348	866	756	981	261	52	305				
BN 200L	55	110 (1)	M20	59	16							878	768	722	64						

**Note**

1. These values refer to the rear shaft end.
2. For FD07 high torque brake value R=226 (consult Power Jacks for more details).

Motor Dimensions - Brake Motor - DC Brake - B14 Face Mount

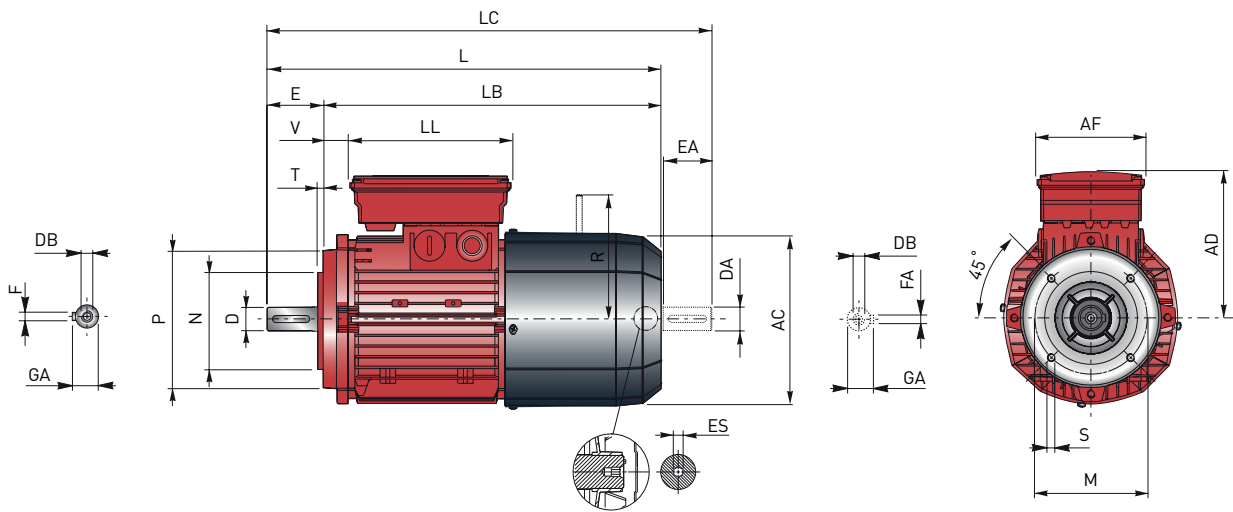

FRAME SIZE	SHAFT					FLANGE					MOTOR										
	D DA	E EA	DB	GA GC	F FA	M	N	P	S	T	AC	L	LB	LC	AD	AF	LL	V	R	ES	
BN 63	11	23	M4	12.5	4	75	60	90	M5	2.5	121	272	249	297	122	98	133	14	96	5	
BN 71	14	30	M5	16	5	85	70	105	M6		138	310	280	342	135			25	103		
BN 80	19	40	M6	21.5	6	100	105	120			156	346	306	388	146			41	129		
BN 90 S	24	50	M8	27	8	115	120	140	M8	3	176	409	359	461	149	110	165	39	129	6	
BN 90 L															146				160		
BN 100	28	60	M10	31		130	110	160		M8	3.5	195	458	398	521			158	62		199
BN 112												219	484	424	547			173	73		
BN 132	38	80	M12	41	10	165	130	200	M10	4	258	603	523	686	210	140	188	46	204 (1)		

**Note**

1. For FD07 high torque brake value R=226 (consult Power Jacks for more details).

FULL RANGE OF COUPLINGS  
AND DRIVE SHAFTS SO YOU  
CAN BUILD COMPLETE  
JACKING SYSTEMS.

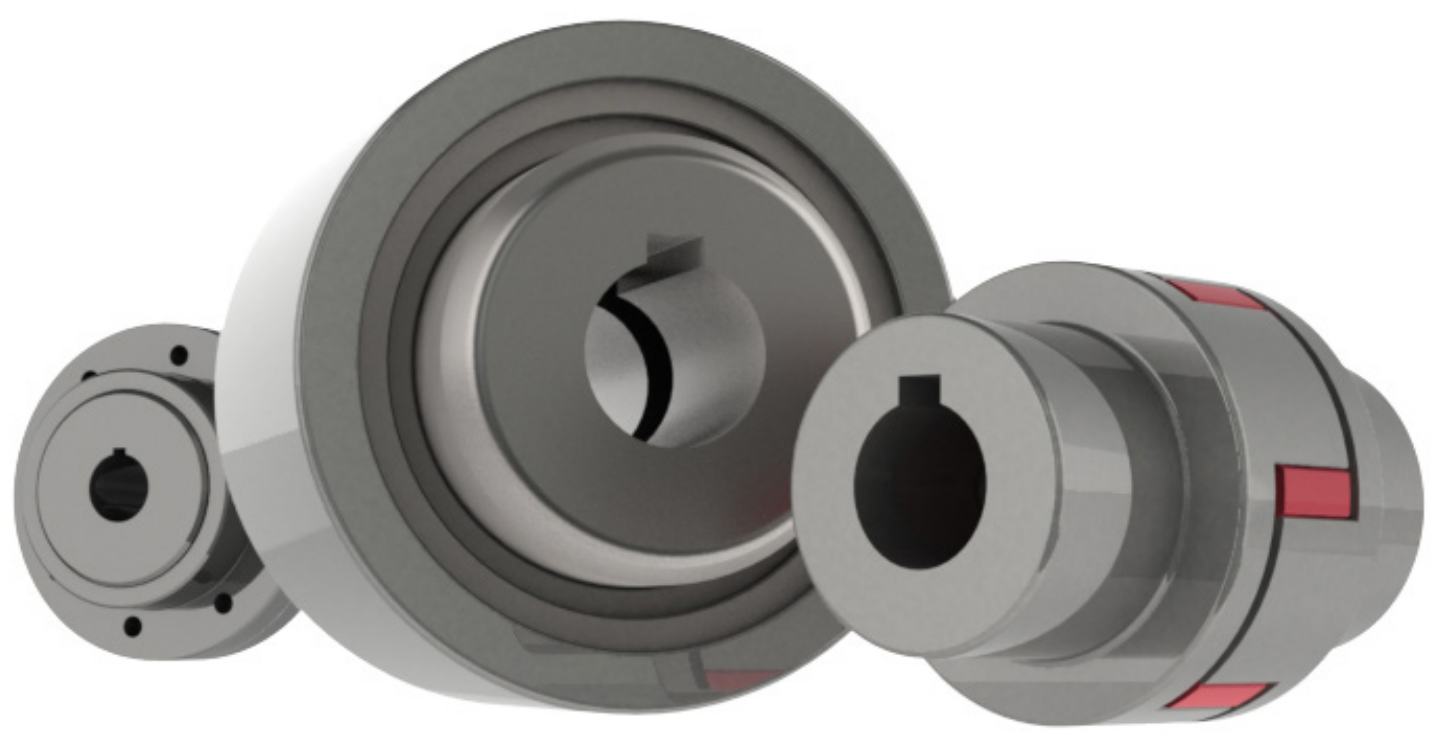

## Flexible Couplings

### Selection of Coupling Type



The selection of coupling type depends on the installation and the type of misalignment. The three main types of misalignment encountered are:-

1. Angular Misalignment is usually present to some extent on all applications, typical values 1° - 2°. Sometimes higher values are necessary.
2. Parallel (Radial) Misalignment is also nearly always present. A well aligned installation might have values below 0.25 mm.
3. Axial Misalignment (End Float) sometimes caused by thermal expansion or as a result of machine design.

### Other considerations include:

- Backlash Free Couplings are either one part couplings or have bolted joints. These are effective for precise positioning and to avoid wear on reversing drives.
- Torsional rigidity of couplings depends on the joining method. Types with rubber or plastic elements can be considered as torsionally soft and will have an amount of twist at rated torque.

### Procedure:

1. Decide if the coupling should be torsionally soft or rigid.
2. Consider whether a small amount of backlash is acceptable.
3. Calculate the required coupling torque.
4. Make a provisional selection.
5. Check that the coupling's maximum speed is sufficient.
6. Check that the coupling's dimensions are acceptable.
7. Contact Power Jacks with your order or technical enquiry

### Selection of Coupling Size:

$$\text{Coupling Torque, T(Nm)} = \frac{9550 * \text{Power Transmitted (kW)} * S}{\text{RPM}}$$

where S = Service Factor - dependant on drive conditions (refer to each coupling) Select the coupling which is rated above the calculated torque. If a brake is present in the system the coupling should be based on either the brake torque or the transmitted torque whichever is greater.

### Note

1. Maximum misalignment values are extremes and should not be combined. As operating misalignment approaches the maximum, torque and power ratings should be reduced to maintain life.
2. Gear couplings accommodate parallel misalignment by converting it to angular misalignment at the gear meshes in the flexible halves of the coupling.
3. The maximum axial misalignment values apply when the coupling is aligned. If axial misalignment greater than the listed maximum is required, consult Power Jacks.
4. The inertia values includes shafts through the bores.
5. When ordering please quote the coupling size and type, specify the bore and keyway sizes, and advise if puller holes or set-screws are required.
6. For maximum performance, the actuators, shafts, Gearboxes and motor should be carefully aligned.
7. Imperial couplings on request.

Keyways	Metric	Imperial
Standard Bores	B.S. 4500 1969 H7	B.S. 1916 Part 1 1953 K7
Standard Keyways	B.S. 4235 Part 1 1967 P9	B.S. 46 Part 1 1958

### Jaw Type Flexible Coupling

- Curved jaw design.
- No need for lubrication.
- Quick and simple to install.
- Reliable, rugged and compact.
- Smooth, silent action.
- High power transmission density.
- 4 Standard spider types available.
- Elastomeric element resistant to heat (-40°C to +90°C), grease, oil and chemical agents.
- Hubs in aluminium and sintered iron.

Size		14	19/24	24/30	28/38	38/45	42/55	48/60	55/70	65/75	75/90	90/100	100/110
Torque (Nm)	Nominal, T <sub>kn</sub>	P	10	35	95	190	265	310	375	425	975	2400	3300
	Max T <sub>kmax</sub>	P	20	70	190	380	530	620	750	850	1950	4800	6600
	Vibrating T <sub>kw</sub> (10Hz)	P	2.6	9	25	49	69	81	93	111	254	624	858
Misalignment Valves	Axial (mm)	P	1.2	1.4	1.5	1.8	2	2.1	2.2	2.6	3	3.4	3.8
	Angular (deg)	P	0.9	0.9	0.9	1	1	1.1	1.1	1.2	1.2	1.2	1.2
	Radial (mm)	P	0.2	0.22	0.25	0.28	0.32	0.36	0.38	0.42	0.48	0.5	0.52
Speed	Max (rpm)	P	14000	10600	8500	7100	6000	5600	4750	4250	3550	2800	2500

**Note** All couplings use 92 Shore elastomeric element (white) as standard. 80, 98 and 95 available on request.  
 Maximum torque must not be exceeded during start-up operation.  
 More accurate alignment will increase coupling life and reduce vibration. Dimensions "E" and "L" must be observed.  
 P = Consult Power Jacks for more details.

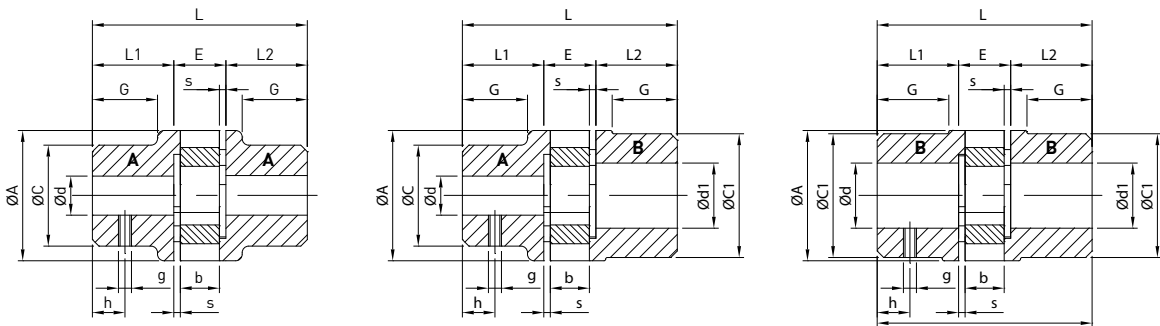

Type	Hub 'A'			Hub 'B'			Dimensions (mm)														Weight kg
	Pre Bore	Min Bore	Max Bore	Pre Bore	Min Bore	Max Bore	A	C	C1	L	L1& L2	E	s	b	G	F	g	h			
<b>Aluminium Hub Couplings</b>																					
19/24	6	6	19	18	20	24	40	31	38	66	25	16	2	12	20	18	M5	10	0.11		
24/30	6	8	24	22	25	30	55	39	48	78	30	18	2	14	24	27	M5	10	0.24		
28/38	9	10	28	26	30	38	65	46	61	90	35	20	2.5	15	28	30	M6	15	0.42		
38/45	12	14	38	36	40	45	80	64	75	114	45	24	3	18	38	38	M6	15	0.86		
<b>Cast Iron Hub Couplings</b>																					
19/24	-	-	-	-	6	24	40	-	40	66	25	16	2	12	-	18	M5	10	0.34		
24/30	-	-	-	-	8	32	55	-	55	78	30	18	2	14	-	27	M5	10	0.9		
28/38	-	-	-	-	10	38	65	-	65	90	35	20	2.5	15	-	30	M6	15	1.5		
38/45	-	14	38	-	40	45	80	66	78	114	45	24	3	18	37	38	M8	15	2.35		
42/55	-	16	42	-	45	55	95	75	93	126	50	26	3	20	40	46	M8	20	3.55		
48/60	-	19	48	-	50	60	105	85	103	140	56	28	3.5	21	45	51	M8	20	4.85		
55/70	-	22	55	53	60	70	120	98	118	160	65	30	4	22	52	60	M10	20	7.4		
65/75	-	25	65	63	70	75	135	115	133	185	75	35	4.5	26	61	68	M10	20	10.8		
75/90	-	30	75	73	80	90	160	135	158	210	85	40	5	30	69	80	M10	25	17.7		
90/100	-	-	-	-	45	100	200	-	170	245	100	45	5.5	34	81	100	M10	25	29.6		
100/110	-	-	-	-	45	110	225	-	180	270	110	50	6	38	89	113	M12	30	39		

**Note** Weight of min. bored coupling with standard A/B hub combination. All couplings metric bored and keyed as standard.  
 Consult Power Jacks for standard bore sizes and specials.

**Service Factor**  $S = Ft * Fz * Fs$

Temperature (°C)	-30°C to +30°C	40°C	60°C	80°C
Temperature Factor (Ft)	1	1.2	1.4	1.8

Starts/Day	0 to 10	101 to 200	201 to 400	401 to 800
Temperature Factor (Ft)	1	1.2	1.4	1.8
Shock Type	None	Light	Medium	High
Shock Factor (Fs)	1	1.2	1.8	2.5

### Flexible Spacer Couplings (Self-Supporting Drive Shafts)

- Compact, light, robust, safe in operation, long service life.
- Two identical hubs and one flexible element.
- Hubs of high tensile steel.
- Large permissible bores, various hub lengths.
- Driving dogs have smooth surface, high durability.
- Generously proportioned compression-stressed flexible inserts.
- Damps vibrations and shocks, compensates for axial, radial and angular misalignment.

#### Elastomeric Element features:

- Inserts made of "90 Shore A" Polyurethane (G) as standard or tough "55 Shore D" Hytrel (H).
- Operating temperature range: -40°C to +80°C as standard
- Elastomeric element is resistant to oil and grease.

#### Coupling Performance

Type	B-G			B-H-G			Max Speed N <sub>max</sub> (rpm) Elastomeric Element
Size	Nominal Torque T <sub>KN</sub> (Nm)	Maximum Torque T <sub>Kmax</sub> (Nm)	Torsional Angle (deg) at T <sub>KN</sub>	Nominal Torque T <sub>KN</sub> (Nm)	Maximum Torque T <sub>Kmax</sub> (Nm)	Torsional Angle (deg) at T <sub>KN</sub>	
72	32	64	4	45	80	2.5	10000
76	63	125	4	90	125	2.5	9000
98	125	250	4	175	280	2.5	7500
120	250	500	4	350	560	2.5	6000
138	400	800	4	560	900	2.5	5000
165	600	1200	4	850	1700	2.5	4000
185	1000	2000	4	1400	2800	2.5	3600

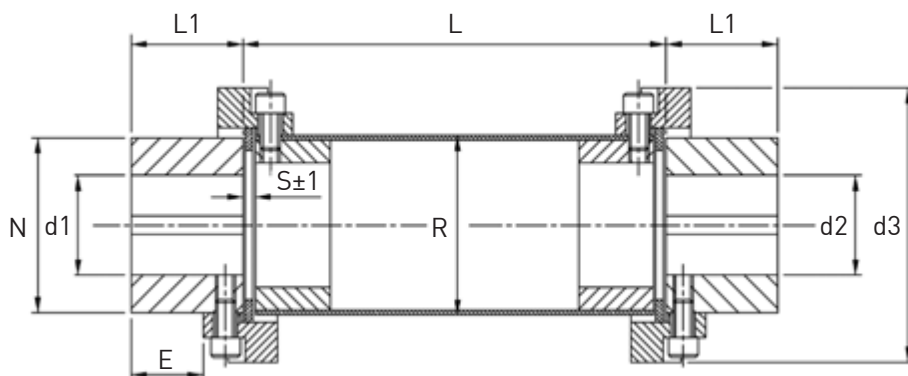

#### Coupling Dimensions

Size	d min (d1, d2)	d max (d1, d2)	d3	E	L1	N	R	S +/- 1	Model	L (minimum)
72	9	30	72	14	28	50	45	6	CF - B - (H) - 72 - G - L = *	100
76	12	30	76	16	30	50	45	6	CF - B - (H) - 76 - G - L = *	100
98	12	38	98	24	42	61	60	6	CF - B - (H) - 98 - G - L = *	100
120	15	48	120	28	50	71	70	6	CF - B - (H) - 120 - G - L = *	100
138	15	55	138	30	55	86	85	6	CF - B - (H) - 138 - G - L = *	140
165	20	65	165	36	65	100	100	8	CF - B - (H) - 165 - G - L = *	180
185	30	80	185	45	80	115	115	10	CF - B - (H) - 185 - G - L = *	180

\* Insert length, L here in millimetres.

#### Misalignment

Element Type	Radial (mm)	Axial (mm)	Angular (deg)
B-Standard	0.5	+/- 1	1
H-Hytrel	0.25	+/- 1	0.5

#### Note

The best possible alignment will result in the best coupling performance.

#### Service Factor

The service factor must be chosen according to working conditions between 1 (light duty) and 3 (arduous duty).

#### Critical Speed & Spacer length

Spacer coupling lengths can be provided up to a maximum of 6m depending on rotational speed.

For advice on the critical speed of a given coupling consult Power Jacks.



## Steel Gear Couplings

### Continuous Sleeve Steel Gear Coupling

- Vari-crown tooth form for improved torque transmission and longer life.
- Strong compact design.
- High transmittable torque ratings.
- Low inertia and high maximum speeds.
- Steel reinforced high misalignment seals.
- Spacer couplings available on request.

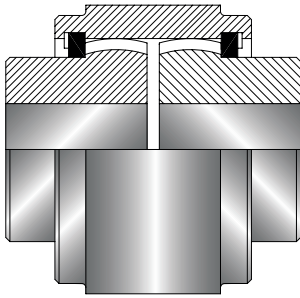

#### Full-Flex Gear Coupling

Two flexible hubs and sleeve assembly. Accommodates angular, parallel and axial misalignments.

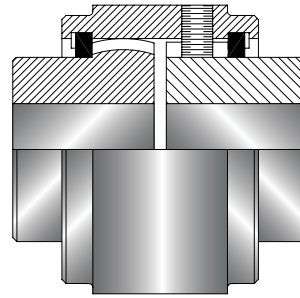

#### Flex-Rigid Gear Coupling

Flexible and rigid hub assembly. The flexible hub is standard and the rigid hub is splined into the sleeve. Accommodates angular and axial misalignment only.

### Flanged Sleeve Steel Gear Coupling

- High transmittable torque ratings and high maximum speeds.
- Accommodates angular, parallel and axial misalignment.
- Strong forged steel hubs and sleeves.
- Vari-crown tooth form improved torque transmission and longer life.
- Several mounting options available by reversing the hubs.
- Spacer gear couplings available. Consult Power Jacks

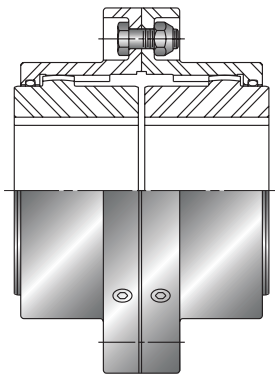

#### Full-Flex Gear Coupling

Two flexible hubs and sleeve assembly. Accommodates angular, parallel and axial misalignments.

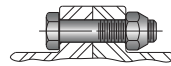

Exposed bolt design also available.

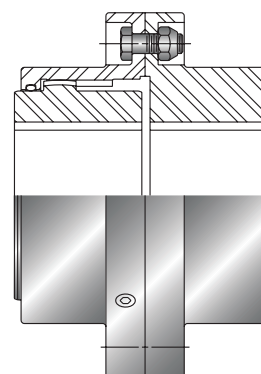

#### Flex-Rigid Gear Coupling

Flexible and rigid hub assembly. Accommodates angular and axial misalignment only.

## Service Factors for Gear Couplings

Nature of Load on Unit	Uniform	Light Shock	Medium Shock	Heavy Shock
Service Factor, S	1.0	1.25	1.5	2.0

### Note

1. All dimensions in millimetres.
2. These couplings are designed for grease lubrication. A list of suggested lubricants and quantities is detailed in the installation manual supplied with each full coupling.
3. Where a coupling is exposed to sustained temperatures above 100°C (212°F) a coupling with high temperature seals must be used, consult Power Jacks Ltd.

#### Steel Gear Couplings - Continuous Sleeve

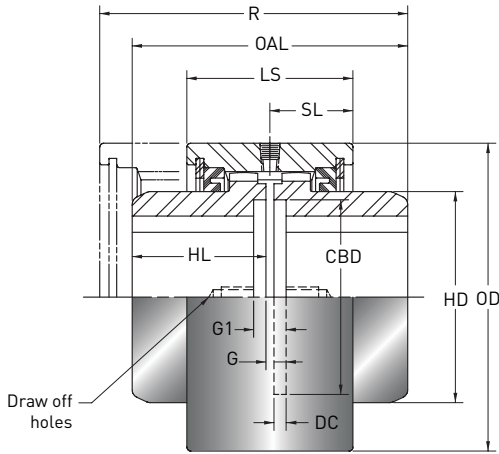

**Full-Flex Gear Coupling**

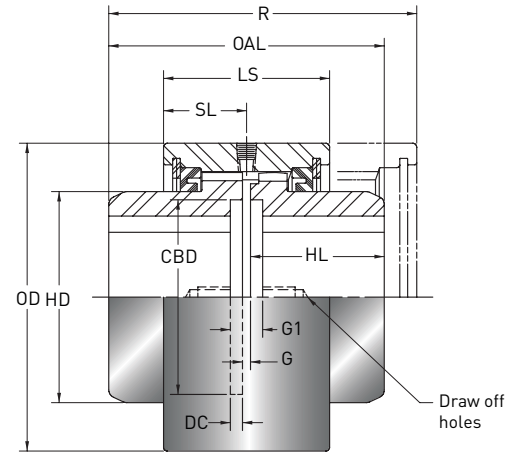

**Flex-Rigid Gear Coupling**

Coupling Size and Type		Full-Flex	CFF022	CFF038	CFF050	CFF065	CFF075	CFF090	CFF100	CFF115
		Flex-Rigid	CFR022	CFR038	CFR050	CFR065	CFR075	CFR090	CFR100	CFR115
Rated Torque (Nm)			285	854	2278	3417	5695	9967	14238	20787
Rated Power (kW/100 rpm)			3	8.9	23.8	35.8	59.6	104.4	149	217.7
Maximum Speed Unbalanced * (rpm)			6000	5000	4200	3750	3000	2800	2400	2200
Full Flex	Maximum Misalignment	Parallel	0.13	0.18	0.18	0.25	0.30	0.30	0.18	0.18
		Angular	1°	1°	1°	1°	1°	1°	1°	1°
		Axial (+/-)	0.3	0.3	0.3	0.6	0.6	0.6	0.6	0.6
Flex Rigid	Maximum Misalignment	Parallel	0.5°	0.5°	0.5°	0.5°	0.5°	0.5°	0.5°	0.5°
		Angular	0.3	0.3	0.3	0.6	0.6	0.6	0.6	0.6
Inertia		(kg m <sup>2</sup> )	0.002	0.004	0.010	0.022	0.053	0.112	0.225	0.376
Weight (Rough Bore)		(kg)	2.3	3.6	5.9	9.1	15	29	41	57
Maximum	Bore		31	42	56	70	84	97	111	130
	Keyway	(b x h)	8 x 7	12 x 8	16 x 10	20 x 12	22 x 14	28 x 16	28 x 16	32 x 18
Rough Bore			11	15	18	22	30	32	44	60
DD			84	95	121	140	168	191	222	241
HD			51	60	83	100	121	137	159	184
HL			38	46	52	57	67	108	111	127
G			3	3	3	6	6	6	6	6
G1			10	13	13	19	19	19	19	19
OAL			80	95	108	121	140	222	229	260
R			95	117	124	145	175	235	241	264
LS			51	64	65	78	95	102	118	124
DC			3	5	5	6	6	6	6	6
CBD			49	57	76	95	121	140	165	184
SL			25	32	33	39	48	51	59	62

**Note** \*Balanced speed approximately 3 times higher. Draw off holes are optional, consult Power Jacks. All dimensions in millimetres.

**Note**

1. Dimension 'R' and 'CAC' are the clearance required to align the coupling when installing.

Steel Gear Couplings - Flanged Sleeve

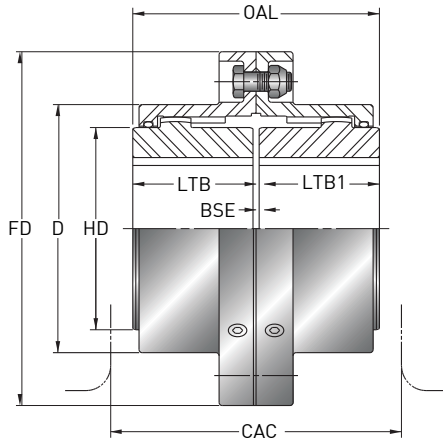

Full-Flex Gear Coupling

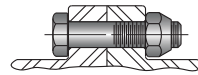

Exposed bolt design also available.

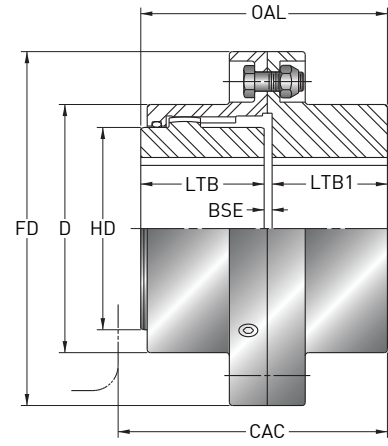

Flex-Rigid Gear Coupling

Coupling Size and Type		Full-Flex	FFF022	FFF038	FFF050	FFF065	FFF075	FFF090	FFF100
		Full-Rigid	FFR022	FFR038	FFR050	FFR065	FFR075	FFR090	FFR100
Rated Torque (Nm)			859	2136	3560	6407	10679	17086	24917
Rated Power (kW/100 rpm)			8.9	22.3	37.3	67.1	111.9	179	261
Maximum Speed Unbalanced * (rpm)			6000	5500	5000	4400	4000	3500	3000
Full Flex	Maximum Misalignment	Parallel	1.4	1.5	2.2	2.7	2.9	3.3	3.8
		Angular	3°	3°	3°	3°	3°	3°	3°
		Axial (per hub)	1.5	1.5	1.5	2.2	2.2	2.2	3.3
Full Rigid	Maximum Misalignment	Angular	1.5°	1.5°	1.5°	1.5°	1.5°	1.5°	1.5°
		Axial (per hub)	1.5	1.5	1.5	2.2	2.2	2.2	3.3
Inertia (kg m <sup>2</sup> )		Full Flex	0.006	0.019	0.044	0.100	0.192	0.435	0.80
		Flex Rigid	0.006	0.020	0.044	0.106	0.203	0.446	0.831
Weight (Rough Bore) (kg)		Full Flex	4	9	15	25	36	59	86
		Flex Rigid	4	8	15	25	39	61	89
Maximum (Flexible Ends)	Bore		42	56	73	88	107	124	147
	Keyway (b x h)		12 x 8	16 x 10	20 x 12	25 x 14	28 x 16	32 x 18	36 x 20
Maximum (Rigid Ends)	Bore		56	76	95	114	134	150	176
	Keyway (b x h)		16 x 10	20 x 12	25 x 14	32 x 18	36 x 20	36 x 20	45 x 25
Rough Bore		FFF	11	18	24	22	37	46	62
		FFR	Solid with Centre						
OAL			89	102	127	159	187	219	248
FD			116	152	178	213	240	279	318
D			78	101	125	150	176	201	235
HD			59	76	102	118	143	165	191
LBT			43	49	62	77	91	106	121
LTB 1			40	47	58	74	87	101	113
BSE		FFF	3	3	3	5	5	6	6
		FFR	4	4	4	5	5	6	8
OAL		FFF	89	102	127	159	187	219	248
		FFR	87	100	124	156	183	213	241
CAC		FFF	106	121	152	181	207	238	260
		FFR	95	109	137	167	192	222	248
Flange Thickness per Hub			14	19	19	22.5	22.5	29	29

**Note** \*Balanced speed approximately 3 times higher. Draw off holes are optional, consult Power Jacks. All dimensions in millimetres.

## Solid Drive Shafts



There are three standard drive shaft sizes offered by Power Jacks with ends machined to suit screw jack system couplings however drive shafts can be supplied to customer sizes with specific end designs

Standard Drive Shafts	Rated Torque (Nm)	Rated Angle of Twist per Metre (Degrees)
20mm Diameter	85	4
30mm Diameter	285	2.6
40mm Diameter	675	2

### Note

1. For other drive shaft types and sizes consult Power Jacks Ltd.
2. For detailed analysis consult Power Jacks Ltd.
3. Dimensions subject to change without notice.

### Select Drive Shaft Diameter

Select a standard drive shaft from the drive shaft table and check its torque rating and angle of twist rating against the application requirements.

If Transmitted Torque (Nm) < Maximum Drive Shaft Torque (Nm)

&

If Acceptable Angle of Twist (Deg.) for shaft length < Rated Angle of Twist for Drive Shaft (Deg.)

Then drive shaft diameter selected is acceptable.

### Shaft Check Drive Shaft Critical Speed

For the unsupported shaft length calculate the drive shaft critical speed for the support conditions required.

If Shaft Speed (rpm) < Drive Shaft Critical Speed (rpm) then drive shaft selection and configuration is acceptable.

### Plummer Block Selection

If the drive shaft selected is not suitable due to the critical speed reduce the unsupported drive shaft length using plummer blocks. e.g. one plummer block at each end of the drive shaft and one in the middle, reducing the unsupported length to half the total drive shaft length.

Select a plummer block from the table relating to the appropriate shaft diameter size.

Re-calculate the critical speed for the new unsupported length and check for acceptability.

If space constraints restrict the number of plummer blocks and the drive shaft fails on the critical speed try increasing the shaft diameter to the next size up or consult Power Jacks for detailed analysis.

### Note

1. For other shaft and plummer block sizes and styles consult Power Jacks Ltd.
2. For detailed shaft analysis and selection consult Power Jacks Ltd.

Solid Drive Shafts

Drive Shaft Critical Speed Factors,  $F_{dcs}$



$$\text{Allowable Drive Shaft Speed (rpm)} = \frac{\text{Critical Speed (rpm) for Unsupported Length "L" (from chart below)}}{\text{Unsupported Length "L" (from chart below)}} \times F_{dcs}$$

Drive Shaft Critical Speed Graph (Shaft Whirling)

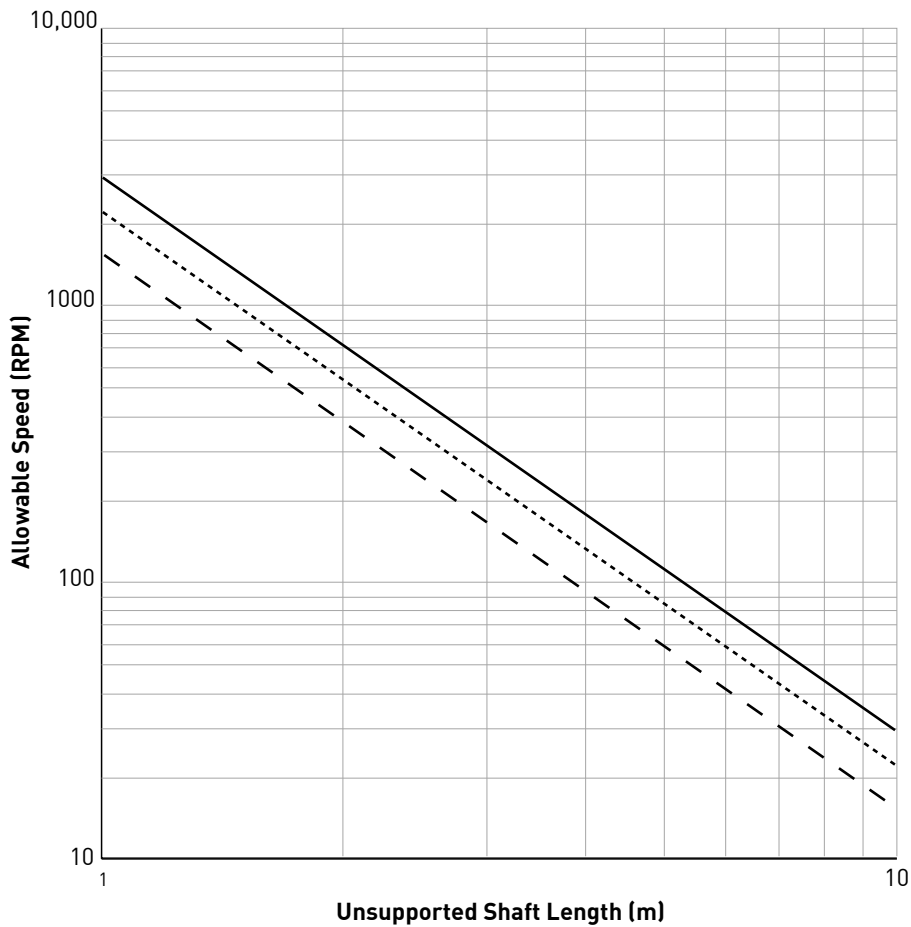

Based on simply supported both ends and 70% of the critical speed.  
 (The factor of safety allows for couplings and slight misalignment)

--- 20mm Diameter    ..... 30 mm Diameter    ——— 40 mm Diameter

#### Plummer Blocks

##### One Piece Housing Plummer Block

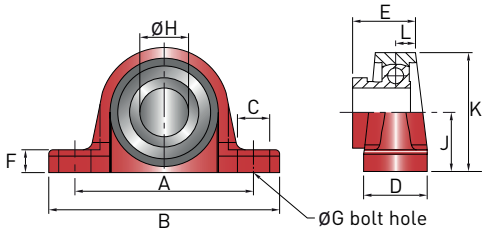

Model	A	B	C	D	E	F	G	H	J	K	L	Weight (kg)
PB1-20	96	127	20.5	32	34	14	10	20	33.33	65	10.5	0.6
PB1-30	121	152	23.5	40	39.2	17	12	30	42.9	82.5	12.5	1.1
PB1-40	136	175	24.5	48	47.7	19	12	40	49.2	99	15	1.9
PB1-50	159	203	26	54	49.7	22	16	50	57.2	115	17	2.8
PB1-60	186	240	29.5	60	60.5	26.5	16	60	69.9	138	21	4.5

##### Note

1. All dimensions in mm.
2. Bore diameter tolerances: (H6+H7)/2.
3. Material: Cast Iron housing with eccentric locking ring.
4. Dimensions are subject to change without notice.
5. For other styles and sizes of Plummer Blocks consult Power Jacks Ltd.

##### Split Housing Plummer Block

Plummer blocks are to DIN736 with anti-friction bearings with tapered bores and adapter sleeve. The housings are made of cast iron and are sealed with felt strips on both sides. The housings are designed to allow floating or located bearings (bearing position set with one or two locating rings). It is recommended when arranging drive systems only one plummer block with located bearing is used in one drive line, to avoid distortion of the drive.

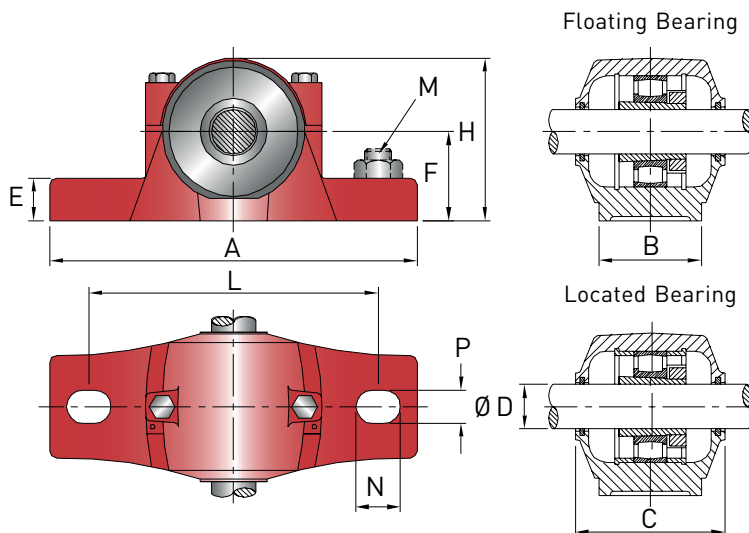

Model	ØD	A	B	C	E	F	H	L	M	N	P	Weight (kg)
PB-20	20	165	46	67	19	40	72	130	M12	20	15	1.4
PB-30	30	185	52	80	22	50	92	150	M12	20	15	2
PB-40	40	205	60	82	25	60	109	170	M12	20	15	2.9

##### Note

1. All dimensions in mm.
2. For other styles and sizes of Plummer Blocks consult Power Jacks Ltd.
3. Dimensions are subject to change without notice.

## Hand Wheels

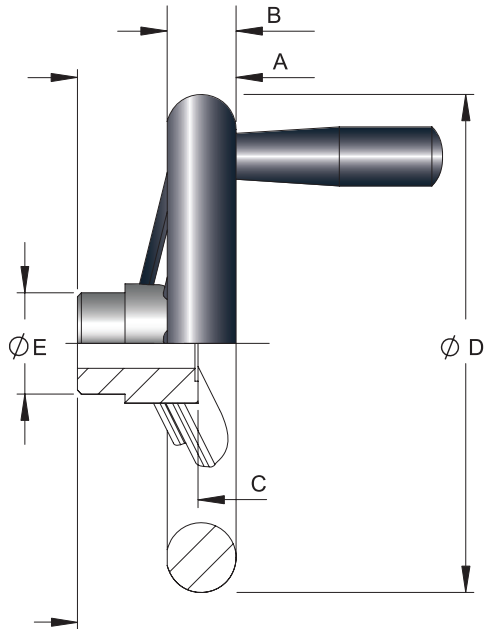

Model	A	B	C	D	E	H7 Bore
HW 005	40	14	36	98	24	Ø10
HW 010	50	22	38	157	32	Ø14
HW 025	56	24	43	198	40	Ø16
HW 050	56	24	43	198	40	Ø19
HW 100	66	30	44	247	49	Ø25
HW 200	78	32	56	288	58	Ø28
HW 300	108	40	77	375	58	Ø35
HW 500	108	40	77	375	58	Ø40

Notes:

1. Material: Polished aluminium casting and rotating handle
2. Bored and keyed to BS4235 Part 1
3. All dimensions in millimetres unless otherwise stated
4. Other types of hand wheels are available on request. Consult Power Jacks.



OUR RANGE OF MOTION CONTROL DEVICES ALLOWS YOU TO SAFEGUARD THE OPERATION OF YOUR SCREW JACK SYSTEM AND ENSURES IT OPERATES WITHIN THE SPECIFIED PARAMETERS

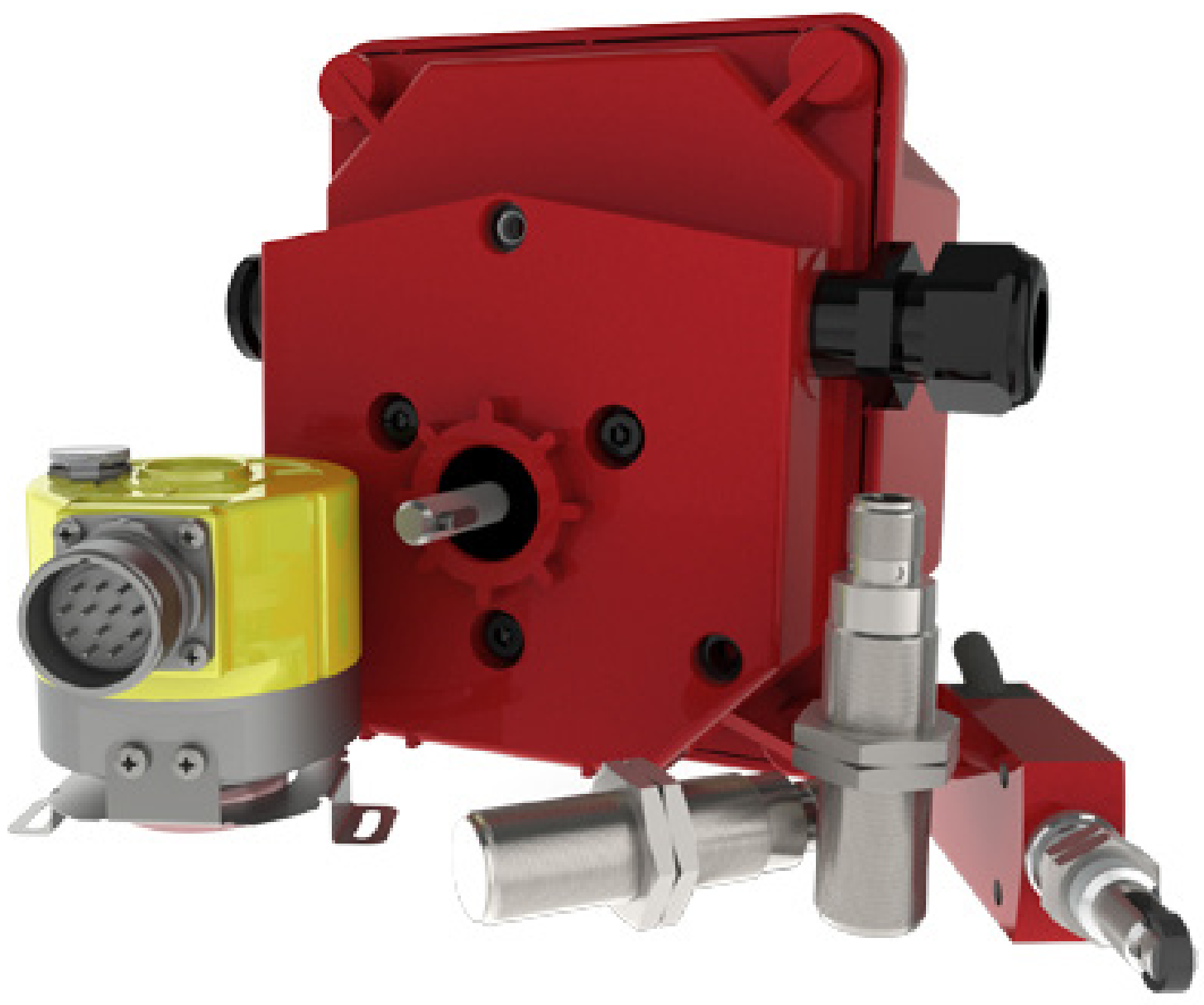

## RLS-51 Geared Cam Limit Switches

Rotary CAM Limit Switches allow a set of limit switches to be fitted to translating or rotating screw jacks by mounting them directly to the screw jacks worm shaft or in-directly via connecting shafts or gearboxes linking to the screw jacks worm shaft. These limit switches are fully adjustable for position over the entire length of the screw jacks stroke. RLS-51 limit switch features include:-

- Usable revolutions from 4.1 to 16,000
- 2 to 8 position limit switch units
- Enclosure IP66 as standard
- Mounting options for B5 Flange, B14 Face and B3 Foot mounted
- Available in three voltages 250V AC, 24V DC & 80V DC
- Modular design to allow a variety of options
- Operating Temperature: -40°C to +80°C

## Illustrated Examples

All units shown are of the 2 limit switch type.



**B14 Face Mount**



**B3 Foot Mount**

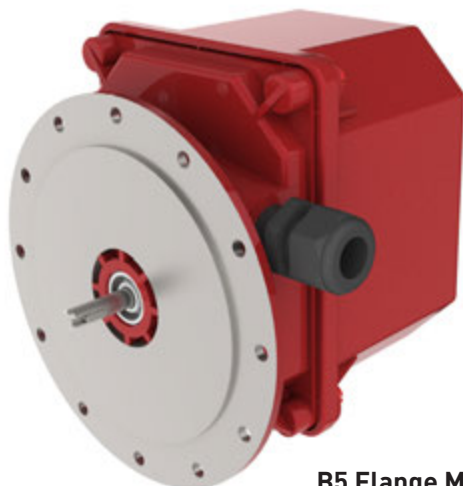

**B5 Flange Mount**

## RLS-51 Features

---

The RLS-51 geared cam limit switches are universal mechanical switching devices that have been designed for use in conjunction with cam discs based on a specific angle of rotation for indication of a large number of shaft revolutions. These cam discs serve to operate mechanical contacts.

Design features include:-

**Low friction planetary gearing** with irreversible, self-locking worm adjustment of the cam discs.

**Fixed cam adjustment in the housing.** The adjusting worms of the cam discs are arranged so that they can be accessed from the same direction as the contact connections for optimal accessibility in confined conditions. Adjustment is possible during operation. The simplicity and accuracy of the cam adjustment is unsurpassed.

**Block adjustment of all switching contacts** jointly is made possible by a single adjusting worm (black) without the switching points of the individual switching contacts being altered with respect to each other.

**Large cam disc diameter** for good adjustability and high switching point repeat accuracy.

**Reinforced polycarbonate housing** as standard with IP66 protection and a wide operating temperature range.

**Modular design** allows adaptation to suit individual requirements via intermediate pieces.

### Options

- Position indicating plate for block adjustment.
- Potentiometer feedback drives (2 available) to suit single and multi-turn potentiometers
- Pulse transmitter with 50 pulses per revolution.
- Anti-condensation heater to prevent condensation and excessively low temperatures in the switches.
- Motor driven contact block adjuster.
- Mounting for encoders (incremental or absolute).
- Extended drive shaft for feedback devices.
- Aluminium housing for harsh environments and the fitment of large and heavy encoders, IP65 enclosure.
- Cam discs with a 40° cam angle can be provided at no extra cost. Other angles can be manufactured at extra cost on request.
- Stage technology tested unit can be provided to V8G 70 with test certificates.

## RLS-51 Performance

Gear size	Usable rev's. selected	Usable rev's. theoretical with 15° cam disc's	Gear Ratio	Input/output stage	No of interim stages	1 rev. of the drive shaft - corresp. to an ang. motion of cam disc = °	Change - over contact reset rev. at driving shaft	max drive speed (rpm)	min drive shaft speed ( only for change - over contact)
1	4.1	4.16	4.285	-	1 x 4.285	84	0.00714	1000	0.67
	6.5	6.88	7.083	1.653	1 x 4.285	50.8	0.0118	1200	1.1
	11	11.23	11.56	2.698	1 x 4.285	31.14	0.0193	1500	1.8
2	17.5	17.84	18.361	-	2 x 4.285	19.6	0.0306	1800	2.9
	29.0	29.5	30.35	1.653	2 x 4.285	11.86	0.0505	1800	4.7
	48	48.13	49.538	2.698	2 x 4.285	7.27	0.0825	1800	7.7
3	75	76.45	78.678	-	3 x 4.285	4.57	0.131	1800	12.2
	125	126.39	130.054	1.653	3 x 4.285	2.77	0.2166	1800	20.2
	205	206.26	212.272	2.698	3 x 4.285	1.69	0.3536	1800	33
4	323	327.6	337.135	-	4 x 4.285	1.06	0.5616	1800	52
	540	541.5	557.284	1.653	4 x 4.285	0.65	0.9284	1800	87
	880	883.8	909.59	2.698	4 x 4.285	0.4	1.515	1800	141
5	1384	1403.7	1444.62	-	5 x 4.285	0.25	2.406	1800	224
	2288	2320.2	2387.96	1.653	5 x 4.285	0.15	3.978	1800	371
	3735	3787.1	3897.58	2.698	5 x 4.285	0.09	6.493	1800	606
6	5900	6014.77	6190.204	-	6 x 4.285	0.06	10.313	1800	*
	9800	9942.2	10232.407	1.653	6 x 4.285	0.04	17.047	1800	*
	16000	16227.6	16701.17	2.698	6 x 4.285	0.02	27.824	1800	*

**\*Caution!** Due to the slow actuation speed of the switching contacts caused by the high gear reductions, the change-over behaviour of the contacts is affected negatively. From gear size 6 it is therefore recommended to use only the normally - closed contacts of the switches. Before using analog feedback systems (eg. potentiometer) please consult our technical department.

**Note:** Maximum permissible relative humidity 60%

### RLS-51 Switching Contacts

The contacts can either be connected through screw terminals for a cable cross section of 0.75mm<sup>2</sup> to 1.5mm<sup>2</sup> or through flat plugs 6.3 x 0.8mm or through a printed card with cage tension spring terminals for a cross section of 0.14 to 2.5mm<sup>2</sup>. For contacts with flat - plug connection, insulated flat - plug receptacles must be used at voltages above 25V AC and 60V DC.

Contact Designation	Contact Type	Contact Material	Switch Actuation	Type of Connection	Electrical Data				Mechanical life in millions of switching operations
					AC - 15		DC - 13		
					A	V	A	V	
99 <sup>1)</sup>	Change-Over	Silver	Snap Action	Screw Terminal	1.5	230	0.5	60	10
99P <sup>1)</sup>	Change-Over	Silver	Snap Action	Flat plug 6.3					
99G <sup>1) 3)</sup>	Change-Over	Gold	Snap Action	Screw Terminal					
92 <sup>2)</sup>	Change-Over	Silver	Snap Action	Screw Terminal					
97 <sup>2) 3)</sup>	Change-Over	Gold	Snap Action	Screw Terminal					
96 <sup>2)</sup>	Normally Closed Contact	Silver	Push Action	Screw Terminal			0.5	60	
99T <sup>4)</sup>									

**Note**

1. Thermal permanent current I<sub>th</sub> = 10A; Reference insulation voltage U<sub>i</sub> = 250V at pollution degree 3
2. Thermal permanent current I<sub>th</sub> = 6A; Reference insulation voltage U<sub>i</sub> = 250V at pollution degree 3
3. Contacts 99G and 97 for PLC applications (gold contacts)
4. For screw terminal admissible cable cross section AWG 22 - 16
5. Positive opening to EN60947T5 - 1 & IEC947 - 5 - 1

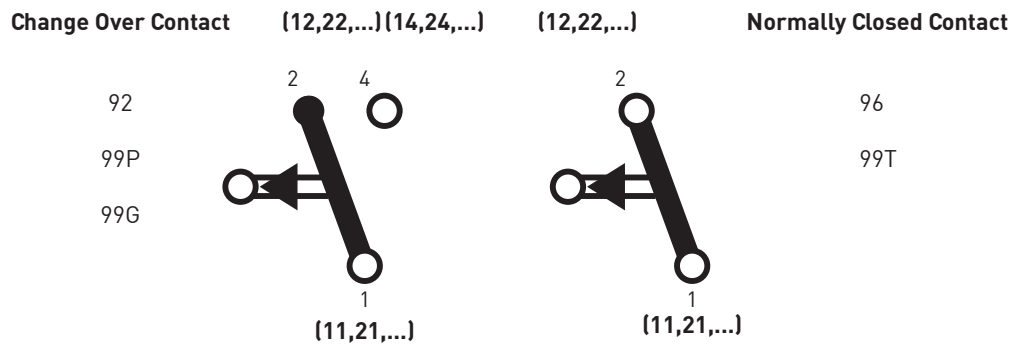





RLS-51 Dimensions

B3, Foot Mount

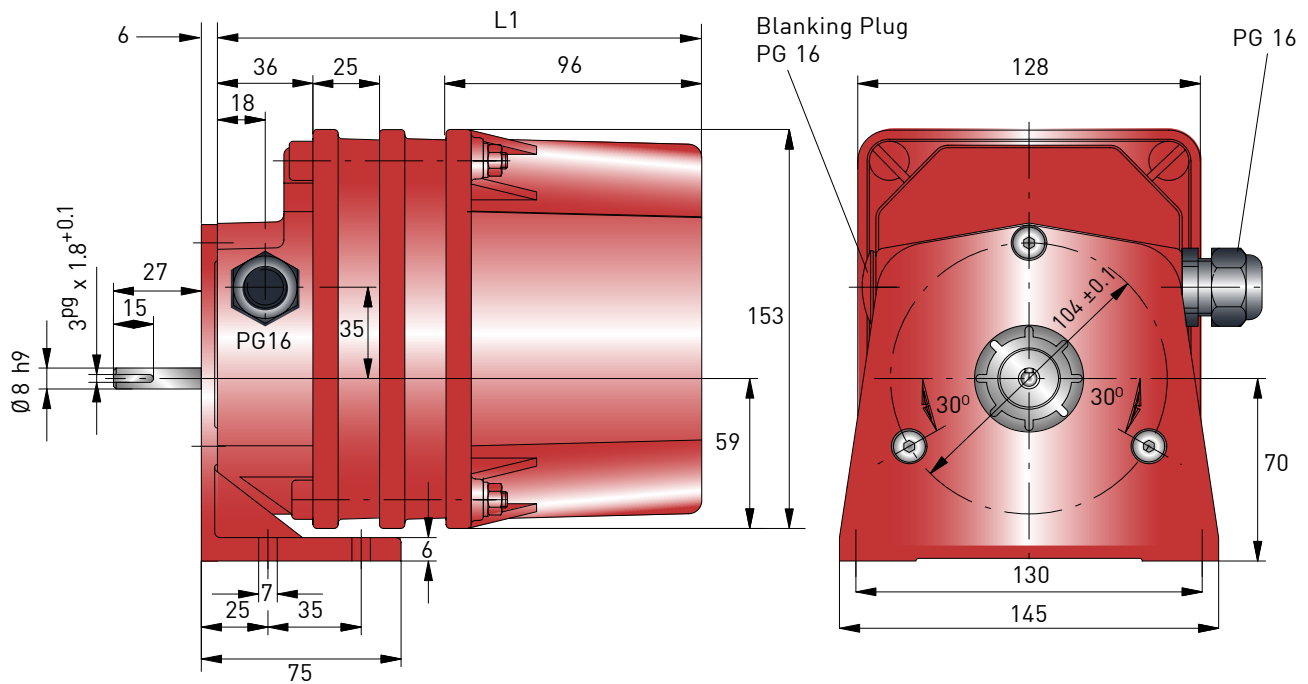

Features:

Housing made of glass fibre reinforced polycarbonate with IP66 degree of protection Modular design enables optimal space utilisation. Overall length can be extended as required with 25mm wide intermediate pieces.

Gear Size	Usable Revs	2 Contacts		4 Contacts		6 Contacts		8 Contacts	
		L1 (mm)	No of intermediate pieces	L1 (mm)	No of intermediate pieces	L1 (mm)	No of intermediate pieces	L1 (mm)	No of intermediate pieces
1	4.1 6.5 11	132	0	132	0	157	1	157	1
2	17.5 29 48	132	0	132	0	157	1	182	2
3	75 125 205	132	0	132	0	157	1	182	2
4	323 540 880	132	0	157	1	182	2	207	2
5	1384 2288 3735	132	0	157	1	182	2	207	3
6	5900 9800 16000	157	1	157	1	182	2	207	3

More than 8 contacts on request

Dimensions with more than 8 contacts and with special executions, eg. potentiometer, on request. For any further intermediate piece add 25mm to L1

### Proximity Sensors

- Inductive Proximity Sensors.
- Non-contact, so no wearing parts.
- 2 Wire sensor for either Normally Closed (NC) or Normally Open (NO) switching.
- Long sensing range.
- Rugged one-piece Metal housing.
- Optical setting aid with 2 LED colour settings:-  
Red LED indicates just in sensing range.  
Yellow LED only indicates within 80% safe sensing range.
- M12 Plug in connection for fast change-ability.
- M12 sockets available straight or angled with 5 m cable.
- Full 360° visibility for switching with 4 yellow LED's at 90° offset.
- Flush face as standard, non-flush available.
- Housing plated brass, Stainless Steel available on request.
- Operating voltage 10 to 30 VDC.
- Enclosure IP67.
- Operating temperature -25°C to +70°C
- Other types available on request. Consult power Jacks.
- Ideal for screw jack end of travel limit switches.

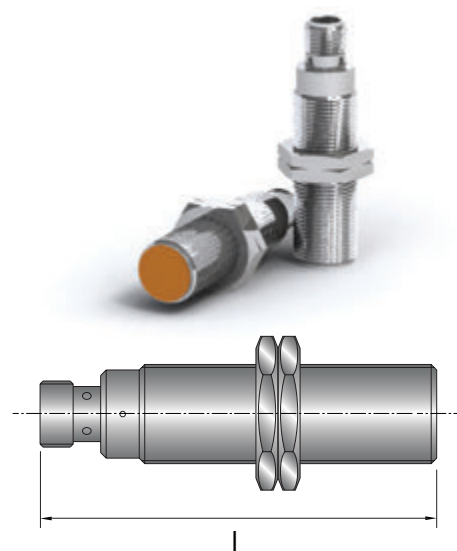

Sensor	M8	M12	M18	M30
Sensing Range (flush)	1mm	4mm	8mm	15mm
Overall Length, L	69mm	62mm	72mm	72mm

Model	M8	M12	M18	M30
Electrical Design	DC PNP/NPN			
Output	normally open/closed	normally open/closed programmable		
Operating Voltage (V)	5 to 36 VDC	10 to 36 VDC		
Current Rating (mA)	200mA	100 mA		400 mA
Minimum Load Current (mA)	4	4		
Short-circuit Protection	No	Pulsed		
Reverse Polarity Protection	No	Yes		
Overload Protection	No	Yes		
Voltage Drop (V)	< 4.6			
Leakage Current (mA)	< 0.8	< 1		< 0.5
Operating Distance (mm)	0 to 0.8	0 to 3.25	0 to 6.48	0 to 12.1
Switch-point Drift (%/Sr)	-10 to 10			
Hysteresis (%/Sr)	1 to 15	1 to 20		3 to 20
Switching Frequency (Hz)	2700	700	400	200
Correction Factors (approx.)				
Mild Steel	1	1	1	1
Stainless Steel	0.7	0.7	0.7	0.7
Brass	0.4	0.5	0.5	0.5
Aluminium	0.3	0.5	0.4	0.5
Copper	0.2	0.4	0.3	0.4
Function Display				
Switching Status LED	1 x yellow	yellow (4 x 90 )		
Setting Aid LED	None	red		
Operating Temperature (°C)	-25 / +80			
Protection	IP 67	IP 67	IP 67	IP 67
Housing Material	brass; special coated; CO-PC			brass white bronze coated; face CO-PC
Connection	M12 connector			

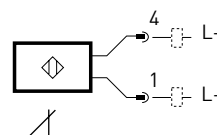
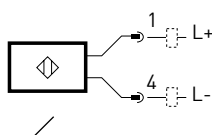

## Compact Electro-Mechanical Contact Limit Switches

### Compact Contact Limit Switch Overview

- Compact electro-mechanical limit switch.
- Sturdy metal enclosure
- Pre-cabled unit.
- High end enclosure protection IP67.
- Available with plug-in connector.
- Other sizes and actuation heads are available on request. Consult Power Jacks.
- Ideal for screw jack end of travel limit switches.

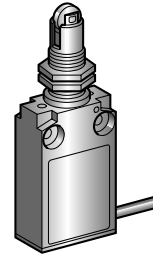

CLS-RPTL  
(a)

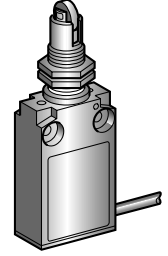

CLS-RPTT  
(b)

Item	Description
Housing	Metal, compact housing, totally enclosed and sealed
Pre-cabled	2m PVC cable 5 x 0.75mm <sup>2</sup> (other cable lengths available on request)
Switch type	Single pole, 1 change-over, snap action
Switch actuation	Steel Roller Plunger a Lateral Cam Approach CSL-RPTL b Travers Cam Approach CSL-RPTT
Max actuation speed	0.5 m/s
Mechanical durability	10 million operating cycles
Ambient temperature Operation Storage	-25 °C to +77 °C -40 °C to +70 °C
Product conformity	IEC947-5-1
Enclosure	IP67
Operating characteristics	AC - 15; B300 (UE = 240V, Ie = 1.5A) DC - 13; R300 (UE = 240V, Ie = 0.1A)
Insulation voltage	Ui = 300V

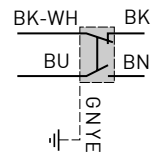

### Compact Contact Limit Switch Dimensions

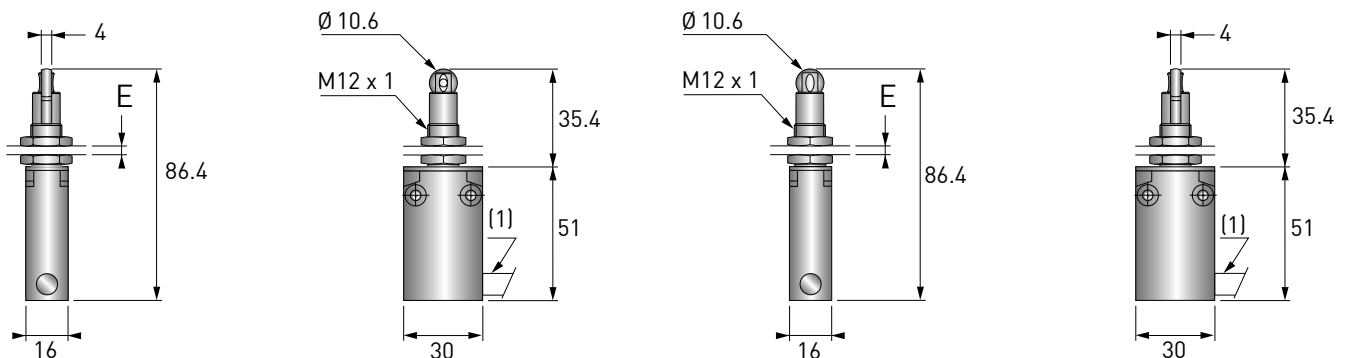

#### Note

1. All dimensions in mm unless otherwise stated.
2. Dimensions subject to change without notice.
3. For dimensions of other switches consult Power Jacks.
4. For a full switch data sheet consult Power Jacks.

E = 8 mm Max, Clearance Diameter Ø12.5 mm  
(1) = Ø8 mm Cable

## Safety Related Electro-Mechanical Contact Limit Switches

### Safety Related Contact Limit Switch Overview

- Positive break Normally Closed contacts - will not stick or weld shut.
- Watertight design to IP67 washdown requirements.
- Rugged corrosion resistant housing tolerates hostile environments.
- Safety system approved.
- Thermoplastic enclosure. Double insulated.
- Snap action with positive-break Normally Closed contact, approved for use in safety systems.
- Alternative actuators heads are available on request. Consult Power Jacks.
- Actuator heads can be repositioned in steps  $4 \times 90^\circ$
- Good resistance to oil and petroleum spirit.
- Actuating force: Min. 9 N.
- Positive break force: 19 N.
- Actuating speed with actuating angle  $30^\circ$  to switch axis. Snap action: Min. 20 mm/min, max. 1 m/s.
- Cable entry: Long Body - 1 cable entry, at end. Short Body - 2 cable entries from sides.
- Ideal for screw jack end of travel limit switches.



### Safety Related Contact Limit Switch Specification

Feature	Description
Standards	IEC/EN 60947-5-1; EN 1088; BG-GS-ET-15
Design	EN 50047
Enclosure material	Glass-fibre reinforced thermoplastic, self-extinguishing
Protection class	IP 67 to IEC/EN 60529/DIN VDE 0470-1
Contact material	Silver
Contact type	Change-over with double break Zb, NC contacts with positive break
Switching system	A IEC 60947-5-1; B BG-GS-ET-15; snap action, NC contacts with positive break
Termination	Screw terminals for max. 2.5 mm <sup>2</sup> cables (including conductor ferrules)
Rated impulse withstand voltage U <sub>imp</sub>	6 kV
Rated insulation voltage U <sub>i</sub>	500 V
Thermal test current I <sub>th</sub>	10 A
Utilisation category	AC-15; DC-13
Rated operating current/voltage I <sub>e</sub> /U <sub>e</sub>	4 A/230 VAC; 2.5 A/400 VAC; 1 A/500 VAC; 1 A/24 VDC
Max. fuse rating	10 A (slow blow); 16 A (quick blow), 6 A (slow blow) as positive break position switch
Ambient temperature	-30 °C to +80 °C
Mechanical life	20 million operations
Switching frequency	Max. 5,000/h
Switching point accuracy	-
Actuating speed **	Min. 10 mm/min
Contact break for complete stroke	2 x 2 mm
Bounce duration	< 3 ms
Switchover time	> 5.5 ms

\*\* For the switch plunger.

#### Note

1. Technical Data subject to change without notice.
2. For a full set of limit switch details consult Power Jacks.

Safety Related Contact Limit Switch Dimensions

Long Body

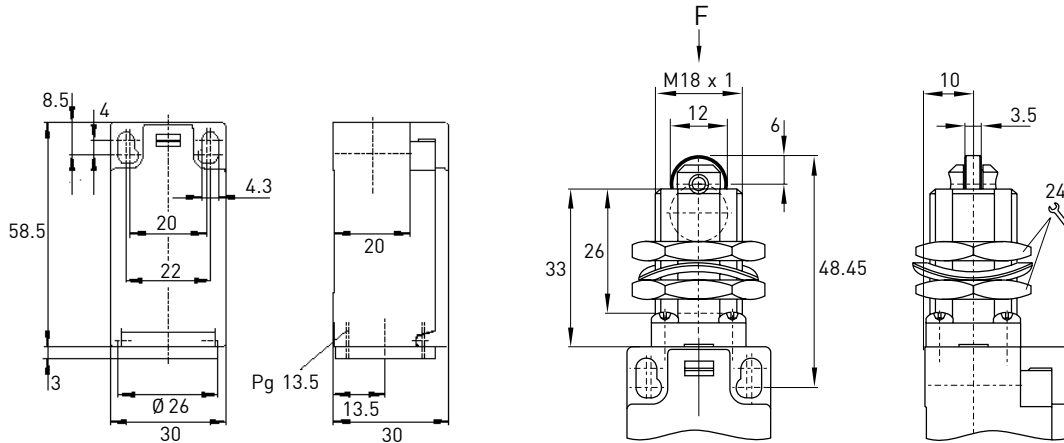

Short Body

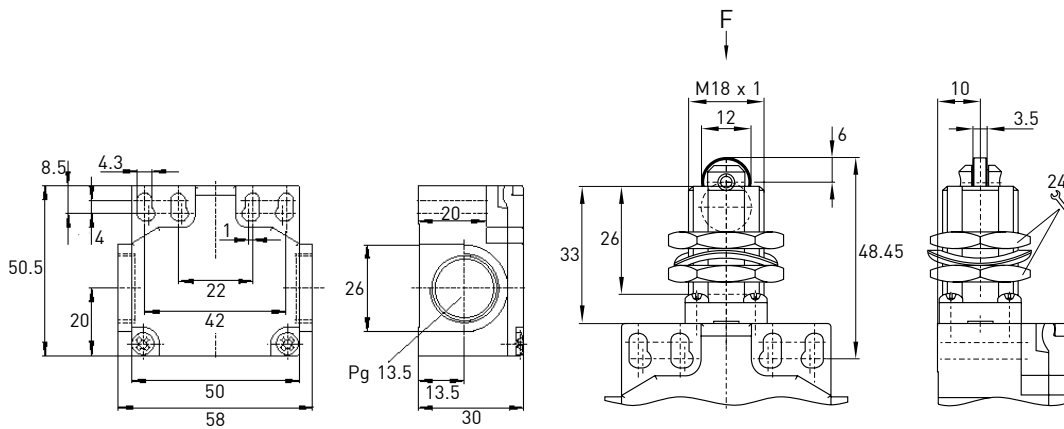

Switch Contacts/Travel

Snap Action

1 NO

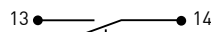

1 NC

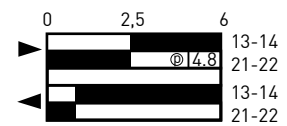
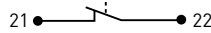

Note

1. All dimensions in mm unless otherwise stated.
2. Dimensions subject to change without notice.
3. For dimensions of other switches consult Power Jacks.
4. For a full switch data sheet consult Power Jacks.

## Incremental Encoders

The DFS60 is a high-resolution incremental encoder in a 60 mm design. The encoder is ideally suited for industrial applications including those with harsh environments due to its high enclosure rating, the large temperature range and robust ball bearing mounts.

- Compact  $\varnothing$  60 mm design
- High-resolution incremental encoder up to 16 bit
- Programming of output voltage level by customer, zero pulse position, zero pulse width and number of lines from 1 to 65536
- Programming using programming tool or machine controller (RS485)
- Plug-in cable output, radial or axial.
- M23 and M12 connector designs, available axial and radial.
- Designs with face mount or servo flange, blind or through hollow shaft.
- Hollow shaft designs up to  $\varnothing$ 15 mm.
- Insulated design available for through hollow shaft.
- Remote zero setting.
- Electrical Interface options include:
  - 4.5 to 5.5 V, TTL/RS422
  - 10 to 32 V, TTL/RS422
  - 10 to 32 V, HTL/push pull
  - 4.5 to 5.5 V, TTL/RS422, with 0-set function on the M23 connector
  - 10 to 32 V, TTL/RS422, with 0-set function on the M23 connector
  - 10 to 32 V, HTL/push pull, with 0-set function on the M23 connector
  - 4.5 to 32 V, TTL/HTL programmable
  - 4.5 to 32 V, TTL/HTL programmable with 0-set function on the M23 connector
- Ambient Temperature Range:
  - Working Temperature – Standard: 0 to +85°C, Optional -30°C to +100°C
  - Working Temperature – Standard: -40°C to +100°C
- Enclosure Rating: IP65 on Shaft and IP67 on housing & connector.
- Standard Shaft Sizes:
  - Blind hollow shaft sizes = 6, 8, 10, 12, 14, 15mm
  - Through hollow shaft sizes = 6, 8, 10, 12, 14, 15mm
  - Solid shaft with flange mount =  $\varnothing$ 10 mm
  - Solid shaft with servo flange mount =  $\varnothing$ 6 mm



### Dimensions – Hollow Blind Shaft

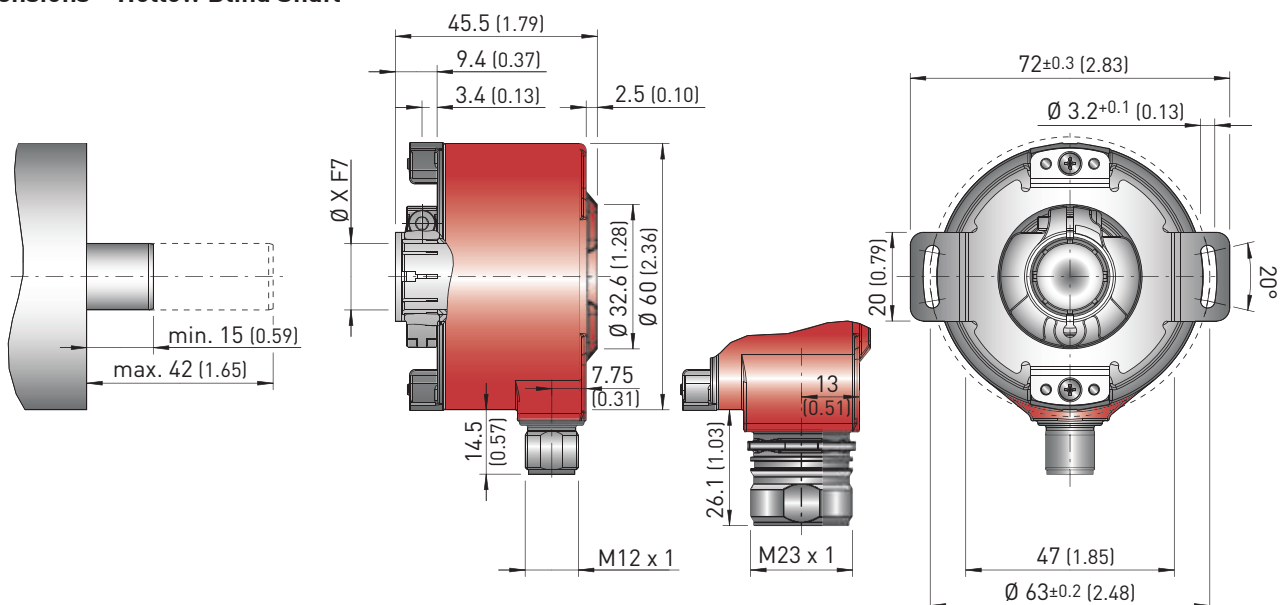

## Absolute Encoders

The AFM60 is a high-resolution multi-turn absolute encoder in a 60mm housing design shared with its incremental counterpart. Ideally suited for industrial applications including those with harsh environments due to its high IP enclosure rating, large temperature range and robust ball bearing mounts. The absolute encoders' use the SSI interface as standard but can also be supplied with combined incremental or Sin/Cos interfaces.

- Compact Ø 60 mm design
- High-resolution absolute encoder up to 30 bit
- Up to 262144 steps per revolution
- Up to 4096 revolutions
- SSI / Gray code.
- Programmable resolution and offset (depends on type).
- Programming using programming tool or machine controller.
- Matched programming cable adapter for M12 & M23 connector available.
- Plug-in cable output, radial or axial.
- M23 and M12 connector designs, available axial and radial.
- Designs with face mount or servo flange, blind or through hollow shaft.
- Hollow shaft designs up to Ø15 mm.
- Operating Voltage 4.5 to 32 V
- Ambient Temperature Range:
  - Working Temperature – Standard: 0 to +85°C, Optional -30°C to +100°C
  - Working Temperature – Standard: -40°C to +100°C
- Enclosure Rating: IP65 on Shaft and IP67 on housing & connector.
- Standard Shaft Sizes:
  - Blind hollow shaft sizes = 8, 10, 12, 14, 15mm
  - Through hollow shaft sizes = 8, 10, 12, 14, 15mm
  - Solid shaft with flange mount = Ø10 mm
  - Solid shaft with servo flange mount = Ø6 mm



### Dimensions – Hollow Blind Shaft

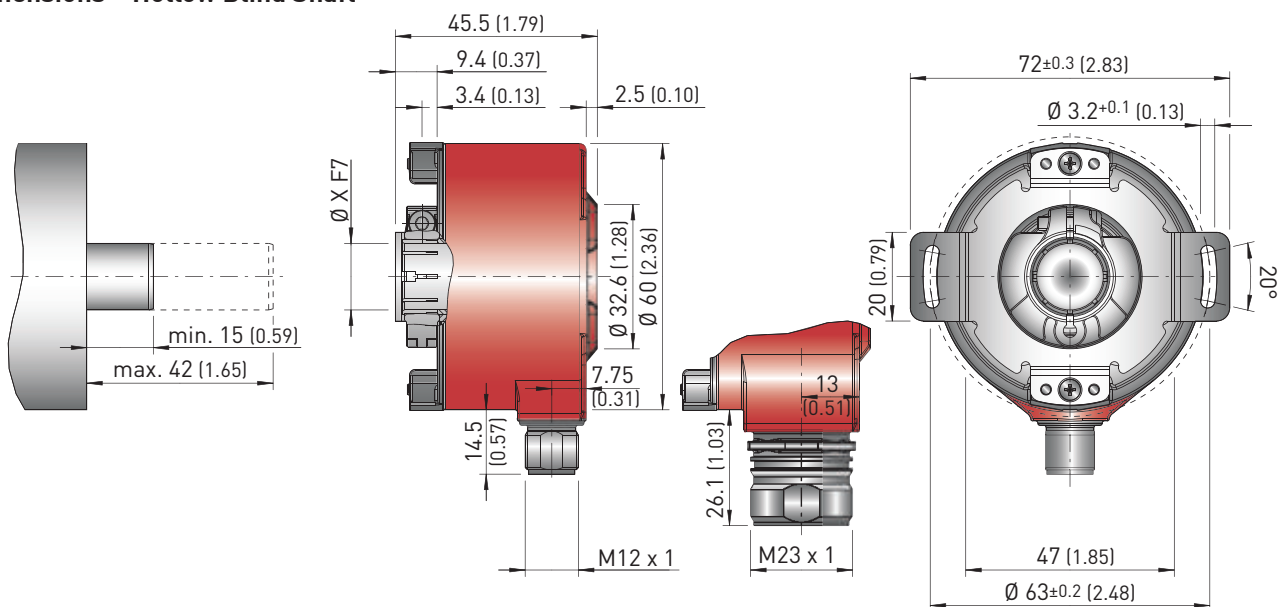



# USEFUL INFORMATION FOR ENGINEERS



Length	m	mm	inch	ft
1 m	1	1000	8mm	3.2808
1 mm	0.001	1	0.03937	$32.8 \times 10^{-3}$
1 inch	0.0254	25.4	1	0.0833
1 ft	0.3048	304.8	12	1

Mass	kg	Tonne	lb	Ton (Short)	Ton
1 kg	1	0.001	2.2046	$1.1023 \times 10^{-3}$	$9.842 \times 10^{-4}$
1 Tonne	1000	1	2204.6	1.1023	0.9842
1 lb	0.4535937	$4.536 \times 10^{-4}$	1	$5 \times 10^{-4}$	$4.464 \times 10^{-4}$
1 Tonne (Short)	907.185	0.907185	2000	1	0.8929
1 Ton	1016.05	1.016	2240	1.120	1

Force / Weight	N	kgf	kp	lbf
1 N	1	0.1019716	0.120	0.224809
1 kgf	9.80665	1	1	2.2046
1 kp	9.80665	1	1	2.2046
1 lbf	4.44822	0.45359237	0.4536	1

Speed	N	mm/s	ft/s	in/s
1 m/s	1	1000	3.2808	39.37
1 mm/s	0.001	1	$3.28 \times 10^{-3}$	0.03937
1 ft/s	0.3048	304.8	1	12
1 in/s	0.0254	25.4	0.0833	1

Torque / Work	Nm	kgf.cm	lbf.in	lbf.ft
1 Nm	1	10.19716	8.8507	0.73756
1 kfg.cm	$9.80665 \times 10^{-2}$	1	0.8679	0.07233
1 lbf.in	0.1129848	1.1521	1	0.08333
1 lbf.ft	1.35582	13.825	12	1

Power	kW	Nm/min	kgf.m/s	hp	lbf.ft/min
1 kW	1	60000	10.20	1.34	44220
1 Nm/min	$1.667 \times 10^{-4}$	1	$1.699 \times 10^{-3}$	$2.235 \times 10^{-5}$	0.7374
1 kgf.m/s	$9.807 \times 10^{-3}$	588.6	1	0.01315	433.73
1 hp	0.7457	44741	76.04	1	33000
1 lbf.ft/min	$2.261 \times 10^{-5}$	1.3566	$2.3056 \times 10^{-3}$	$3.03 \times 10^{-5}$	1

Inertia	kg.m <sup>2</sup> (mr <sup>2</sup> )	kpms <sup>2</sup>	lbf.ft <sup>2</sup> (WK <sup>2</sup> )	lbf.in <sup>2</sup> (WK <sup>2</sup> )
kg.m <sup>2</sup> (mr <sup>2</sup> )	1	0.10197	23.73	3417.2
1 kpms <sup>2</sup>	9.807	1	232.6	33488
1 lbf.ft <sup>2</sup> (WK <sup>2</sup> )	0.0421	$4.30 \times 10^{-3}$	1	144
1 lbf.in <sup>2</sup> (WK <sup>2</sup> )	$2.9264 \times 10^{-4}$	0.6192	$6.944 \times 10^{-3}$	1

Stress / Pressure	MPa [N/mm <sup>2</sup> ]	N/m <sup>2</sup>	kg/cm <sup>2</sup>	lbf/inch <sup>2</sup>	lbf/ft <sup>2</sup>
1 MPa [N/mm <sup>2</sup> ]	1	$1 \times 10^{-6}$	10.2	145.039	20885.6
1 N/m <sup>2</sup>	$1 \times 10^{-6}$	1	$10.2 \times 10^{-6}$	$145 \times 10^{-6}$	$20.88 \times 10^{-6}$
1 kg/cm <sup>2</sup>	$9.807 \times 10^{-2}$	$9.81 \times 10^3$	1	14.2233	$2.05 \times 10^3$
1 lbf/inch <sup>2</sup>	$9.8947 \times 10^{-3}$	$6.89 \times 10^3$	0.070307	1	144
1 lbg/ft <sup>2</sup>	$4.7879 \times 10^{-5}$	47.88026	$0.488 \times 10^{-3}$	$6.94 \times 10^{-3}$	1

Temperature	
T °F	$(T \text{ °C} \times 1.8) + 32^\circ$
T °C	$(T \text{ °F} - 32) / 1.8$

### IEC Ratings

1st Digit : Solid Ingress		2nd Digit : Liquid Ingress	
0	No special protection	0	No special protection
1	A large surface of the body, such as hand (but no protection against deliberate acces.) Solid objects >50 mm diameter.	1	Dripping water (vertically falling drops).
2	Fingers or similar objects not exceeding 80mm in length. Solid objects >12mm in diameter.	2	Vertically dripping water when the enclosure is tilted at any angle up to 15° from its normal position.
3	Tools, wires, etc. of diameter or thickness >2.5mm. Solid objects >1mm diameter.	3	Water falling as a spray at an angle of 60° from the vertical.
4	Wires or strips of thickness >1mm. Solid objects >1mm diameter.	4	Water splashed against the enclosure from any direction.
5	Ingress of dust is not totally prevented, but dust does not enter in sufficient quantity to interfere with satisfactory operation of the equipment.	5	Water projected by a nozzle against the enclosure.
6	No ingress of dust.	6	Water from heavy seas or projected in powerful jets.
		7	Ingress of water in a harmful quantity not possible when the enclosure is immersed under defined conditions of pressure and time.
		8	Submersible under defined conditions of pressure and time.

### NEMA and IEC Equivalent Enclosures

Since the IEC degree of protection for enclosed equipment is defined differently from NEMA type enclosure protection, and methods of test are different, exact correlation between IEC IP-type designations and NEMA types is not possible. It is possible to make rough comparisons, which may result in certain applications. The common NEMA type designations compare with IEC designations as follows:

NEMA Type		Nearest IEC Equivalent	
NEMA 1	General protection of people from live parts. Protection against falling dirt. Test: 1/8" to 1/2" (3.175 to 12.7mm) rod entry test and rust resistance tests.	IP2X (1)	Protected against solid objects greater than 12mm. Test: Metallic test finger and 12mm sphere tests. No IEC rust resistance test.
NEMA 3	Dust-tight and sleet resistant. Test: Rain, dust, external icing and rust resistance test.	IP54	Dust protected. Protected against splashing water. Test: Dust and oscillating sprinkler tests. No IEC rust resistance test.
NEMA 3R	Rain-proof and sleet resistant. Test: Rod entry 1/8" to 1/4" (3.175 to 6.35mm), rain, external icing and rust resistance tests.	IP34	Protected against solid objects greater than 2.5mm. Protected against splashing water. Test: 2.5mm rod and oscillating sprinkler tests. No IEC rust resistance or icing tests.
NEMA 4	Water-tight and dust-tight. Test: Hosedown, rust-resistance and external icing tests.	IP65	Dust-tight and protected against water jets. Test: Dust and spray nozzle tests. no rust resistance or external icing test.
NEMA 4X	Water-tight, dust-tight and corrosion resistance. Test: Hosedown, corrosion resistance and external icing tests.	IPW65 (2)	Dust-tight and protected against water jets. Test: Dust and spray nozzle tests. No rust resistance or external icing test.
NEMA 7	Hazardous gas.	-	No IEC equivalent.
NEMA 9	Hardous dust.	-	No IEC equivalent.
NEMA 12	Dust-tight and drip-tight. Test: Drip, dust and rust resistance tests.	IP61	Dust-tight and protected against dripping water. Test: Dust and rain simulator tests. No IEC rust resistance test.
NEMA 18	Oil tight and dust tight. Test: Oil-tightness and rust-resistance tests.	IP6X (1)	Dust-tight. Test: Dust test. No IEC oil-tightness or rust resistance tests.

### Note

1. When only one characteristic numeral is used the second numeral is replaced by an 'X'.
2. 'W' inserted after the 'IP' indicates suitable for a specified weather condition (conditions and features specified by manufacturer).

Thread Size	Pitch	Hexagon Bolts & Nuts			Sockets Head Cap Screw																																																																																		
		A	H	K	R	T	W																																																																																
M3	0.50	5.5	2.125	2.4	5.5	3.0	2.5																																																																																
M4	0.70	7.0	2.925	3.2	7.0	4.0	3.0																																																																																
M5	0.80	8.0	3.650	4.0	8.5	5.00	4.0																																																																																
M6	1.00	10.0	4.150	5.0	10.0	6.0	5.0																																																																																
M8	1.25	13.0	5.650	6.5	13.0	8.0	6.0																																																																																
M10	1.50	17.0	7.180	8.0	16.0	10.0	8.0																																																																																
M12	1.75	19.0	8.180	10.0	18.0	12.0	10.0																																																																																
(M14)	2.00	22.0	9.180	11.0	21.0	14.0	12.0																																																																																
M16	2.00	24.0	10.180	13.0	24.0	16.0	14.0 </tr <tr> <td>(M18)</td> <td>2.50</td> <td>27.0</td> <td>12.215</td> <td>15.0</td> <td>27.0</td> <td>18.0</td> <td>14.0</td> </tr> <tr> <td>M20</td> <td>2.50</td> <td>30.0</td> <td>13.215</td> <td>16.0</td> <td>30.0</td> <td>20.0</td> <td>17.0</td> </tr> <tr> <td>(M22)</td> <td>2.50</td> <td>32.0</td> <td>14.215</td> <td>18.0</td> <td>33.0</td> <td>22.0</td> <td>17.0</td> </tr> <tr> <td>M24</td> <td>3.00</td> <td>36.0</td> <td>15.215</td> <td>19.0</td> <td>36.0</td> <td>24.0</td> <td>19.0</td> </tr> <tr> <td>(M27)</td> <td>3.00</td> <td>41.0</td> <td>17.215</td> <td>22.0</td> <td>40.0</td> <td>27.0</td> <td>19.0</td> </tr> <tr> <td>M30</td> <td>3.50</td> <td>46.0</td> <td>19.620</td> <td>24.0</td> <td>45.0</td> <td>30.0</td> <td>22.0</td> </tr> <tr> <td>(M33)</td> <td>3.50</td> <td>50.0</td> <td>21.260</td> <td>26.0</td> <td>50.0</td> <td>33.0</td> <td>24.0</td> </tr> <tr> <td>M36</td> <td>4.00</td> <td>55.0</td> <td>23.260</td> <td>29.0</td> <td>54.0</td> <td>36.0</td> <td>27.0</td> </tr> <tr> <td>(M39)</td> <td>4.00</td> <td>60.0</td> <td>25.260</td> <td>31.0</td> <td>-</td> <td>-</td> <td>-</td> </tr> <tr> <td>M42</td> <td>4.50</td> <td>65.0</td> <td>26.260</td> <td>34.0</td> <td>63.0</td> <td>42.0</td> <td>32.0</td> </tr>	(M18)	2.50	27.0	12.215	15.0	27.0	18.0	14.0	M20	2.50	30.0	13.215	16.0	30.0	20.0	17.0	(M22)	2.50	32.0	14.215	18.0	33.0	22.0	17.0	M24	3.00	36.0	15.215	19.0	36.0	24.0	19.0	(M27)	3.00	41.0	17.215	22.0	40.0	27.0	19.0	M30	3.50	46.0	19.620	24.0	45.0	30.0	22.0	(M33)	3.50	50.0	21.260	26.0	50.0	33.0	24.0	M36	4.00	55.0	23.260	29.0	54.0	36.0	27.0	(M39)	4.00	60.0	25.260	31.0	-	-	-	M42	4.50	65.0	26.260	34.0	63.0	42.0	32.0
(M18)	2.50	27.0	12.215	15.0	27.0	18.0	14.0																																																																																
M20	2.50	30.0	13.215	16.0	30.0	20.0	17.0																																																																																
(M22)	2.50	32.0	14.215	18.0	33.0	22.0	17.0																																																																																
M24	3.00	36.0	15.215	19.0	36.0	24.0	19.0																																																																																
(M27)	3.00	41.0	17.215	22.0	40.0	27.0	19.0																																																																																
M30	3.50	46.0	19.620	24.0	45.0	30.0	22.0																																																																																
(M33)	3.50	50.0	21.260	26.0	50.0	33.0	24.0																																																																																
M36	4.00	55.0	23.260	29.0	54.0	36.0	27.0																																																																																
(M39)	4.00	60.0	25.260	31.0	-	-	-																																																																																
M42	4.50	65.0	26.260	34.0	63.0	42.0	32.0																																																																																

**Hexagon Bolt**

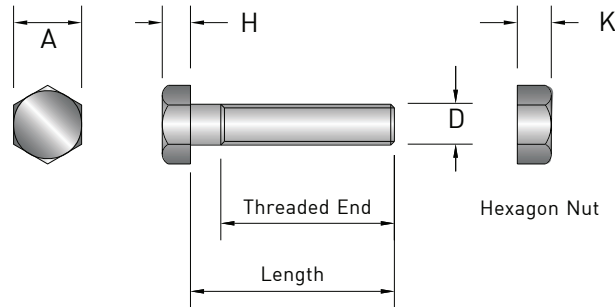

**Socket Head Cap Screw**

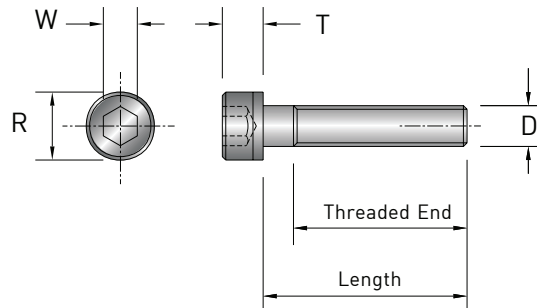

**Note**

1. All dimensions in millimetres.
2. Sizes in brackets are non-preferred standards.
3. All dimensions are maximum sizes.

### Enlarged Detail of Key and Keyways

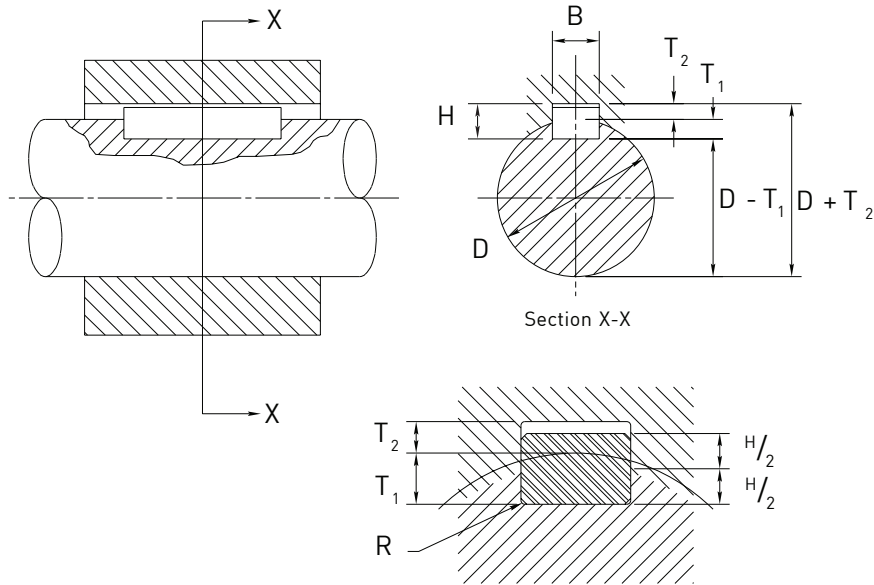

Symbol		Key	Keyway											
Nominal Diameter D		B x H width x thick-ness	Nom	Width, B					Depth				Radius, R	
				Tolerance for class of fit					Shaft, T1		Hub, T2			
Over	Incl			Free	Normal	Close and Interference	Nom.	Tol.	Nom.	Tol.	Max.	Min.		
		Shaft (H9)	Hub (D10)	Shaft (N9)	Hub (Js9)	Shaft and Hub (P9)								
6	8	2 x 2	2	+0.025	+0.060	-0.004	+0.012	-0.006	1.2	+0.1	1.0	+0.1	0.16	0.08
8	10	3 x 3	3	0	+0.020	-0.029	-0.012	-0.031	1.8	0	1.4	0		
10	12	4 x 4	4	+0.030	+0.078	0	+0.015	-0.012	2.5		1.8			
12	17	5 x 5	5	0	+0.080	-0.030	-0.015	-0.042	3.0		2.3		0.25	0.16
17	22	6 x 6	6						3.5		2.8			
22	30	8 x 7	8	+0.036	+0.095	0	+0.018	-0.015	4.0	+0.2	3.3	+0.2		
30	38	10 x 8	10	0	+0.040	-0.036	-0.018	-0.051	5.0	0	3.3	0	0.40	0.25
38	44	12 x 8	12						5.0		3.3			
44	50	14 x 9	14	+0.043	+0.120	0	+0.021	-0.018	5.5		3.8			
50	58	16 x 10	16	0	+0.050	-0.043	-0.021	-0.061	6.0		4.3			
58	65	18 x 11	18						7.0		4.4			
65	75	20 x 12	20						7.5		4.9		0.60	0.40
75	85	22 x 14	22	+0.052	+0.149	0	+0.026	-0.022	9.0		5.4			
85	95	25 x 14	25	0	+0.065	-0.052	-0.026	-0.074	9.0		5.4			
95	110	28 x 16	28						10.0		6.4			
110	130	32 x 18	32						11.0		7.4			
130	150	36 x 20	36	+0.062	+0.180	0	+0.031	-0.022	12.0	+0.3	8.4	+0.3	1.00	0.70
150	170	40 x 22	40	0	+0.080	-0.062	-0.031	-0.088	13.0	0	9.4	0		
170	200	45 x 25	45						13.0		10.4			

**Note**

For full range and further information refer BS 4235: Pt 1: 1972



**Physical Property Values, at 20°C**

Material	Carbon Steel	Aluminium Alloys	Brass 65/35	Copper	Stainless Steel
Density, $\rho$ (kg/m <sup>3</sup> )	7860	2710	8450	8910	7750
Young's Modulus, E (GN/m <sup>2</sup> )	207	710	105	119	190
Shear Modulus, G (GN/m <sup>2</sup> )	79.3	26.2	38	44.7	73.1
Bulk Modulus, K (GN/m <sup>2</sup> )	172	57.5	115	130	178
Poisson's Ratio, $\nu$	0.292	0.334	0.35	0.326	0.305
Coefficient of Thermal Expansion $\times 10^{-6}/K$	12	22	19	17	14
Specific Heat J/kg K	460	920	420	420	460

**Note**

Values given are representative. Exact values may vary with composition and processing, sometimes greatly.

**Standard SI Prefixes \* †**

Name	System	Factor
exa	E	1 000 000 000 000 000 000 = 10 <sup>18</sup>
peta	P	1 000 000 000 000 000 = 10 <sup>15</sup>
tera	T	1 000 000 000 000 = 10 <sup>12</sup>
giga	G	1 000 000 000 = 10 <sup>9</sup>
mega	M	1 000 000 = 10 <sup>6</sup>
kilo	k	1 000 = 10 <sup>3</sup>
hecto ‡	h	100 = 10 <sup>2</sup>
deca ‡	da	10 = 10 <sup>1</sup>
deci ‡	d	0.1 = 10 <sup>-1</sup>
centi ‡	c	0.01 = 10 <sup>-2</sup>
milli	m	0.001 = 10 <sup>-3</sup>
micro	$\mu$	0.000 001 = 10 <sup>-6</sup>
nano	n	0.000 000 001 = 10 <sup>-9</sup>
pico	p	0.000 000 000 001 = 10 <sup>-12</sup>
femto	f	0.000 000 000 000 001 = 10 <sup>-15</sup>
atto	a	0.000 000 000 000 000 001 = 10 <sup>-18</sup>

\* If possible use multiple and submultiple prefixes in steps of 1000.

† Spaces are used in SI instead of commas to group numbers to avoid confusion with the practise in some European countries of using commas for decimal points.

‡ Not recommended but sometimes encountered.

### Limitation of Responsibility

The ratings given in this catalogue were compiled using standard engineering procedures. The ratings are designed to guide the customer in the selection of a unit. We do not guarantee the ratings in specific applications. Prototype testing of every application is recommended before production. Our engineering facilities are available for consultation at all times. Please ask us for assistance with linear motion and drive application problems. This catalogue is designed to assist in the selection of a suitable linear motion or power transmission product for economical, long and trouble free service.

Due to Power Jacks policy of continuous improvement designs may be subject to change without notice. Please ask for certified drawings.

## Warranty Definitions

When used in these conditions the following words have the meanings set out opposite them below:

Company: Power Jacks Limited  
Contract: The contract between the Company and the Customer for the supply of the Goods.  
Customer: The party to whom the Goods are to be supplied under the Contract  
Goods: The goods to be provided under the Contract  
Writing: Includes facsimile or electronic transmission and comparable means of communication

## Warranty Definitions

The Company warrants that any Goods sold by it under Power Jacks standard terms and conditions of sale will be free from defects caused by faulty materials or poor workmanship but gives no warranty and makes no representation whatsoever express or implied as to any other matters including without limitation condition merchantability or fitness for any purpose.

The Company shall incur no liability under this warranty unless:

- The Company is promptly notified in Writing upon discovery of any such defects by the Customer and the Customer forthwith ceases to use the defective Goods unless otherwise authorised by the Company; and
- The defective item is immediately returned to the Company, transportation charges being prepaid by the Customer or the Company is, at its option, given the opportunity to remedy any defect.

The Company's warranty as specified above is limited to a period of 12 months from the date of delivery (ex-works Power Jacks) and its liability shall be limited to replacing, repairing or issuing credit at its option for any Goods returned by the Customer within the aforesaid period.

The Company shall not be liable for consequential loss or damage by reason of any defect in (or failure to comply with any written estimate of performance of) Goods supplied by the Company whether original or substituted.

The Customer will indemnify the Company against all third party claims made in respect of the Goods.



Power Jacks specialises in the design and manufacture of precision linear actuation, positioning and lifting equipment.

Our products are supplied globally across many sectors including Industrial Automation, Energy, Transport, Defence and Civil.

Power Jacks Ltd  
Kingshill Commercial Park  
Prospect Road, Westhill  
Aberdeenshire AB32 6FP  
Scotland (UK)  
Tel: +44 (0)1224 968968

[www.powerjacks.com](http://www.powerjacks.com)  
[sales@powerjacks.com](mailto:sales@powerjacks.com)

PJDG-SJ-EN-03



All information in this document is subject to change without notice. All rights reserved by Power Jacks Limited.  
May not be copied in whole or in part. ©Power Jacks Limited 2024, Aberdeenshire, Scotland, United Kingdom.